

Bonito PRO

X-1250



- Latest CMOS sensor
- CXP-6 speed
- PoCXP
- 142.6 fps at full resolution

加速您的高分辨率应用 稳健型高带宽相机系列

Bonito PRO X-1250 搭载 ON Semi PYTHON 12K 传感器，在 12.5 MP 分辨率下速度可达 142 帧/秒。

Bonito PRO 是 Allied Vision 旗下的高带宽相机系列，搭载 CoaXPress 接口。此款相机配备 4 个 DIN 1.0/2.3 连接器，能通过 4 条 CXP-6 高速连接通道以 25 Gbps 的速率进行数据传输。Bonito PRO 采用坚固的无风扇外壳设计，功能强大，兼顾高通量、稳健性和设计灵活性等各个方面，是需要高分辨率成像应用的不二之选。

与 Allied Vision 的 **Vimba 套件** 轻松集成，并与流行的 **第三方图像处理库** 兼容。

请参阅关于镜头接口、外壳选项、光学滤镜、外壳设计和其他模块化选项。如需特别定制，请参阅 **OEM 定制方案** 网页。

性能参数

接口	CoaXPress (CXP-6) 4 DIN
分辨率	4096 (H) × 3072 (V)
传感器	ON Semi PYTHON 12K
传感器类型	CMOS
快门种类	GS (Global shutter)
传感器尺寸	Type 4/3
像元尺寸	4.5 μm × 4.5 μm
Lens mounts (available)	F-Mount, F-Mount PA, EF-Mount PA, M42-Mount, M42-Mount PA, M58-Mount, M58-Mount PA
最大满帧帧率	142.6 fps
ADC	10 Bit
非易失性内存 (Flash)	1024 KByte, 完全满足 16 帧 640 × 480 像素应用

成像性能

Imaging performance data is based on the evaluation methods in the EMVA 1288 Release 3.1 standard for characterization of image sensors and cameras. Measurements are typical values for monochrome models measured without optical filter.

在波长为 529nm 下, 量子转换效率	53 %
暗噪声	19.8 e ⁻
饱和电子数	7600 e ⁻
动态范围	51.3 dB
绝对灵敏度阈值	20.5 e ⁻

输出

Bit 位数	10-bit
黑白像素格式	Mono8, Mono10
Raw 彩色像素格式 (Bayer)	BayerRG8, BayerRG10

通用输入输出口 (GPIOs)

TTL I/Os	1 input, 2 outputs
光耦 I/Os	1 input, 2 outputs

工作条件/尺寸

工作温度 -20 °C to +70 °C housing (without condensation)

电源要求 (DC) 24 VDC; PoCXP

功耗 External power: 15.7 W at 24 VDC | Power over CoaXPress: 15.7 W

重量 500 g (with F-Mount)

尺寸 (L × W × H in mm) 114.9 × 70 × 70 (with F-Mount and connectors)

量子转换效率

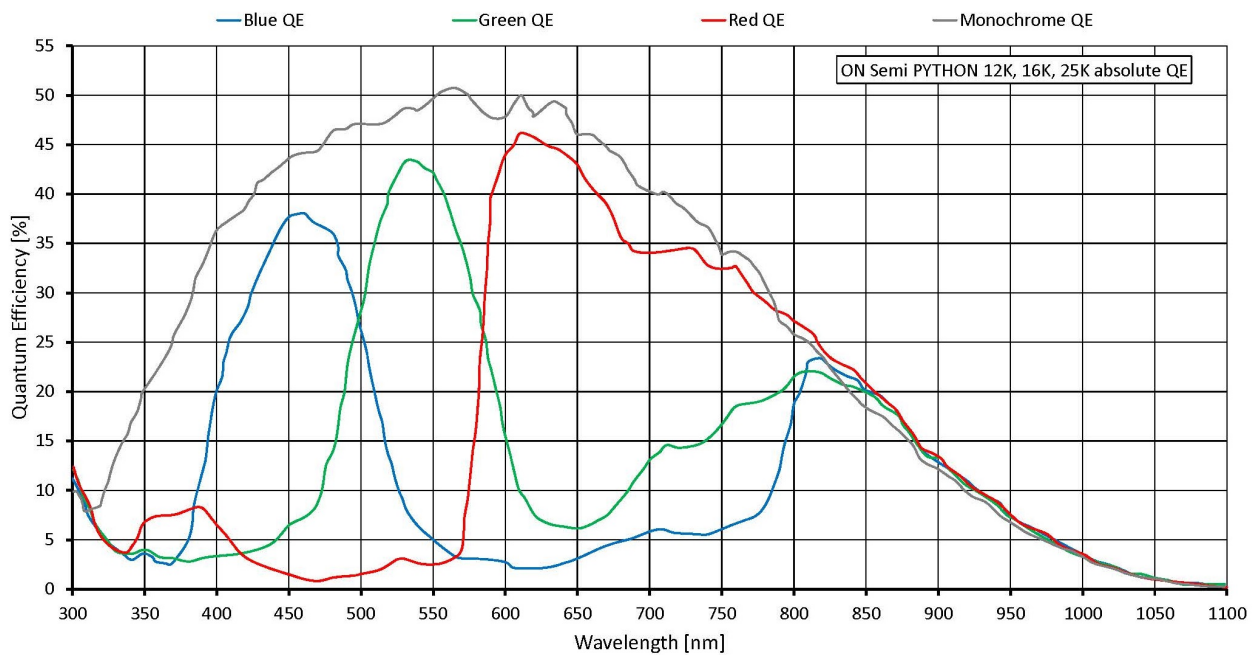

特性

Image optimization features:

- Auto gain (manual gain control: 0 to 22 dB)
- Auto exposure (manual exposure control: 1 μ s to 1 s)
- Auto white balance (X-1250C only)
- Binning (horizontal and/or vertical), (sum or average)
- Decimation X/Y
- Gamma correction
- Three look-up tables
- Defect Pixel Correction
- Fixed Pattern Noise Correction

Camera control features:

- Multiple region of interest
- Sequencer Control
- Trigger over CoaXPress
- EF lens control (order option -18)
- Storable user sets
- Sync out modes: Trigger ready, input, exposing, readout, imaging, strobe, GPO
- Temperature monitoring (main board and sensor board)

外形尺寸

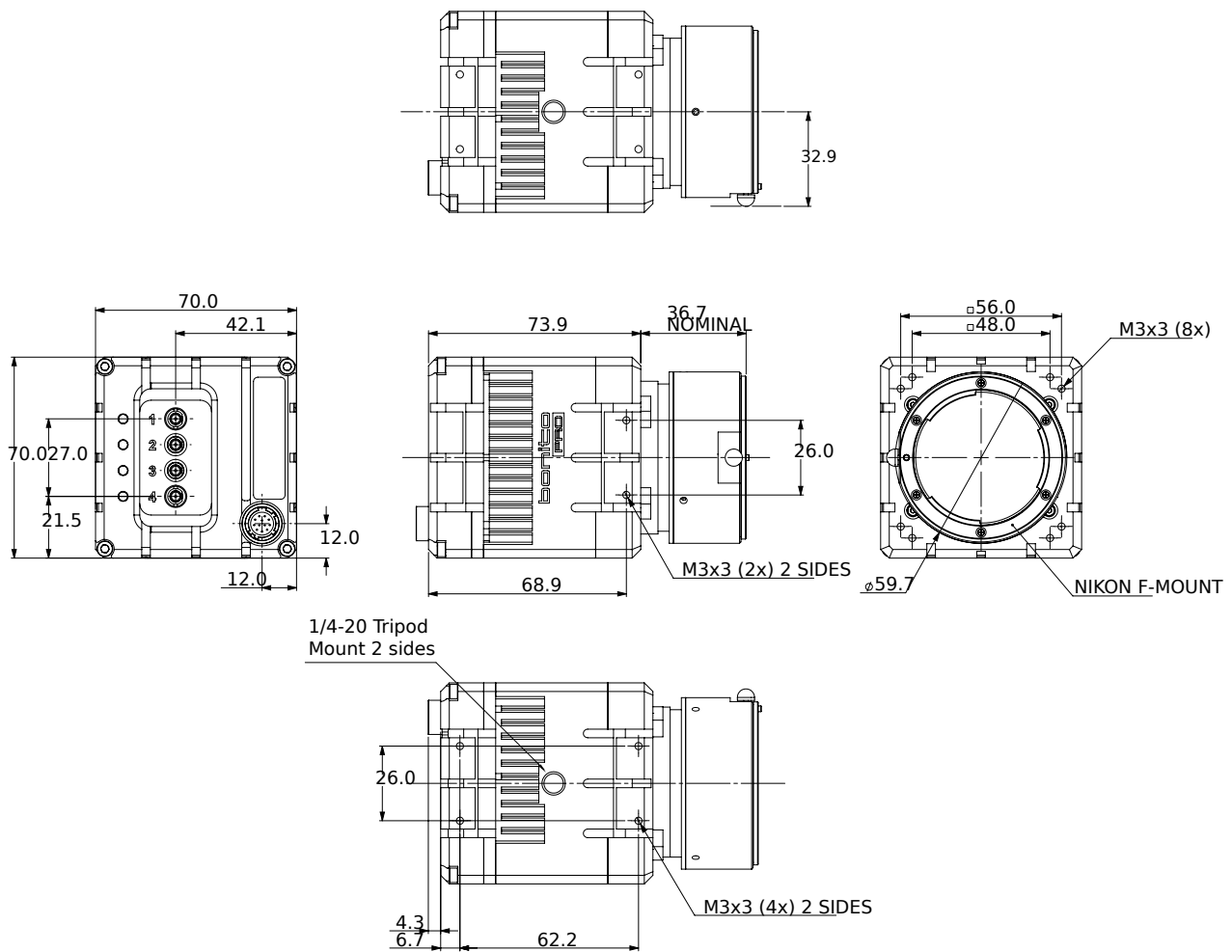

应用场景

Bonito PRO X-1250 is ideal for a wide range of applications including:

- Automated Optical Inspection of flat panel displays, PCB/electronics, printings
- 2D/3D Surface Inspection (for example, glass)
- Aerial imaging