



GIGE VISION & CAMERA LINK SWIR CAMERAS

# Goldeye G/CL

## User Guide

V4.7.2

FW 05.04.b71da924

Note: Lenses are not part of this product.

**Quick links**

- [Goldeye G/CL cameras at a glance](#) on page 15
- [Contact us](#) on page 17
- [Contents](#) on page 18

# Read before use

## EN - English

### Safety

Before using the camera, read these safety instructions. Observe the warnings at all times. Use the camera only as stated in the [Intended use](#) on page 41.

**CAUTION****Risk of burns**

A camera in operation can reach temperature levels which could cause burns.

**CAUTION****Injury by falling cameras or lenses**

A falling camera or lens can cause injury.

**CAUTION****Risk of cuts by sharp edges of lens mounts**

The threads of the lens mount can have sharp edges.

### Intended use

Intended use of Allied Vision product is the integration into vision systems by professionals. All Allied Vision product is sold in a B2B setting.

## DA - Dansk

### Sikkerhed

Læs sikkerhedsanvisningerne, før kameraet bruges. Overhold alle advarsler. Brug kun kameraet som anført i [Intended use](#) på side 41.



#### FORSIGTIG

##### **Forbrændingsfare**

Når kameraet bruges, kan det blive meget varmt og forårsage forbrændinger.



#### FORSIGTIG

##### **Kvæstelser, hvis kameraet eller linser falder ned**

Falder kameraet eller linsen ned, kan dette forårsage kvæstelser.



#### FORSIGTIG

##### **Fare for snitsår på linsemodulets skarpe kanter**

Linsemodulets gevind kan have skarpe kanter.

### Tilsløbet brug

Allied Vision produktets tilsløbet brug er en indbygning i et visionssystem, udført af fagfolk. Alle Allied Vision produkter sælges i B2B.

## DE - Deutsch

### Sicherheit

Bevor Sie die Kamera benutzen, lesen Sie diese Sicherheitshinweise. Beachten Sie diese Hinweise immer. Verwenden Sie die Kamera nur wie beschrieben in [Intended use](#) auf Seite 41.



#### VORSICHT

##### **Gefahr von Verbrennungen**

Im Betrieb kann die Kamera Temperaturen erreichen, die zu Verbrennungen führen.



#### VORSICHT

##### **Verletzung durch fallende Kameras oder Objektive**

Eine fallende Kamera oder ein fallendes Objektiv kann Verletzungen verursachen.



#### VORSICHT

##### **Schnitte durch scharfkantige Objektivgewinde**

Objektivgewinde können scharfe Kanten haben.

### Bestimmungsgemäßer Gebrauch

Allied Vision Produkte sind bestimmt für die Integration in Bildverarbeitungssysteme durch Fachpersonal. Alle Allied Vision Produkte werden in einer B2B-Umgebung verkauft.

## ES - Español

### Seguridad

Antes de utilizar la cámara lea estas instrucciones de seguridad. Observe las advertencias en todo momento. Utilice la cámara solo tal y como se estipula en el [Intended use](#) en la página 41.



#### ATENCIÓN

##### **Riesgo de quemaduras**

Una cámara en funcionamiento puede alcanzar temperaturas que podrían provocar quemaduras.



#### ATENCIÓN

##### **Lesiones en caso de que las cámaras o las lentes se caigan**

Si una cámara o una lente se cae puede provocar lesiones.



#### ATENCIÓN

##### **Riesgo de cortes debido a los bordes afilados del objetivo**

Las roscas de los objetivos pueden tener bordes afilados.

### Uso previsto

El uso previsto del producto Allied Vision es la integración en el sistema de visión por parte de profesionales. Todos los productos Allied Vision se venden dentro de una relación B2B.

## FI - Suomi

### Turvallisuus

Lue nämä turvallisuusohjeet ennen kameran käyttöä. Noudata varoituksia joka hetki. Käytä kameraa ainoastaan kohdassa [Intended use](#) sivulla 41 kuvatulla tavalla.



#### HUOMIO

##### **Palovammojen vaara**

Käytössä olevan kameran saavuttamat lämpötilatasot voivat aiheuttaa palovammoja.



#### HUOMIO

##### **Putoavien kameroiden tai linssien aiheuttamat vammat**

Putoava kamera tai linssi voi aiheuttaa vammoja.



#### HUOMIO

##### **Linssien kiinnikkeiden terävien reunojen aiheuttamien viiltovammojen vaara**

Linssin kiinnikkeiden kierteiden reunat voivat olla teräviä.

### Käyttötarkoitus

Allied Vision-tuotteen käyttötarkoitus on integrointi kuvajärjestelmiin ammattilaisten toimesta. Kaikki Allied Vision-tuotteet myydään B2B-ympäristössä.

## FR - Français

### Sécurité

Veillez lire ces consignes de sécurité avant d'utiliser la caméra. Respectez continuellement les avertissements. Utilisez la caméra uniquement comme indiqué sous [Intended use](#), page 41.



#### ATTENTION

##### Risque de brûlures

Une caméra en service peut atteindre des niveaux de température susceptibles d'entraîner des brûlures.



#### ATTENTION

##### Blessures en cas de chute de caméras ou d'objectifs

La chute d'une caméra ou d'un objectif peut entraîner des blessures.



#### ATTENTION

##### Risque de coupures sur les bords tranchants des montures d'objectif

Les filetages des montures d'objectif peuvent présenter des bords tranchants.

### Utilisation prévue

L'utilisation prévue du produit Allied Vision est son intégration dans des systèmes de vision par le soin de professionnels. Tout produit Allied Vision est vendu dans un cadre B2B.

## עברית - HE

### בטיחות

לפני השימוש במצלמה, עליך לקרוא את הוראות הביטחון האלו. עליך לממש הוראות ביטחון אלו תמיד. השימוש במצלמה הוא רק לפי מה שכתוב ב"כוונת השימוש" (Intended use) בעמוד 41.

#### זהירות

##### סכנת כווייה

בזמן הפערת המצלמה עלולות טמפרטורות גבוהות לעלות, שיכולות לגרום לכוויות.



#### זהירות

##### פגיעה מנפילת מצלמות או עדשות

מצלמה או עדשה שנופלות עלולות לגרום לפגיעה.



#### זהירות

##### סכנה להחתך מתבריג חד של העדשה

תבריג תושבת העדשה עלול להיות חד עד כדי פגיעה.



### שימוש מיועד

מוצרי AlliedVision מיועדים לשילוב במערכות ממוחשבת לעיבוד צילומים ע"י אנשי מקצוע. כל מוצרי AlliedVision נמכרים לשימוש בסביבת B2B.



## IT - Italiano

### Sicurezza

Leggere queste istruzioni per la sicurezza prima di utilizzare la telecamera. Osservare sempre tutte le avvertenze. Utilizzare la telecamera come descritto alla sezione [Intended use](#) a pagina 41.



#### ATTENZIONE

##### **Pericolo di ustioni**

Durante il funzionamento una telecamera può raggiungere temperature elevate che possono essere causa di ustioni.



#### ATTENZIONE

##### **Lesioni dovute alla caduta di telecamere o lenti**

La caduta di una telecamera o di una lente può causare delle lesioni.



#### ATTENZIONE

##### **Pericolo di tagliarsi sui bordi affilati degli attacchi della lente**

I bordi della filettatura dell'attacco della lente possono essere affilati.

### Uso previsto

Il prodotto Allied Vision è concepito per essere integrato in sistemi di monitoraggio in campo professionale. Tutti i prodotti Allied Vision sono venduti in uno scenario B2B.

## JA – 日本語

### 安全性

本カメラを使用する前に、この安全の手引きをお読みください。常に、警告事項を守ってください。必ず、[Intended use 41](#) ページの通りに、本カメラを使用してください。



#### 注意

やけどの危険性

作動中のカメラは、やけどを引き起こす温度まで熱くなる恐れがあります。



#### 注意

カメラまたはレンズの落下によるけが

カメラまたはレンズが落下すると、けがをする恐れがあります。



#### 注意

レンズマウントの鋭利な端部で切り傷の危険性

レンズマウントのギザギザの部分が鋭利である可能性があります。

### 用途

Allied Vision製品は、専門家が視覚装置に統合することを意図したものです。すべてのAllied Vision製品は、企業間取り引き用に販売されています。

## NL - Nederlands

### Veiligheid

Lees deze veiligheidsinstructies voordat u de camera gaat gebruiken. Neem deze waarschuwingen altijd in acht. Gebruik de camera uitsluitend, zoals aangegeven in het [Intended use](#) op pagina 41.



#### VOORZICHTIG

##### Risico van verbranding

Een camera die gebruikt wordt, kan temperatuurwaarden bereiken die brandwonden kunnen veroorzaken.



#### VOORZICHTIG

##### Letsel door vallende camera's of lenzen

Een vallende camera of lens kan letsel veroorzaken.



#### VOORZICHTIG

##### Risico van snijwonden door scherpe randen van lensbevestigingen

Het schroefdraad van de lensbevestiging kan scherpe randen hebben.

### Beoogd gebruik

Het beoogde gebruik van het Allied Vision-product is de integratie in optische systemen door professionals. Alle Allied Vision-producten worden verkocht in de B2B-markt.

## NO - Norsk

### Sikkerhet

Les disse sikkerhetsinstruksene før du bruker kameraet. Følg advarslene til en hver tid. Bruk kun kameraet i samsvar med [Intended use](#) på side 41.



#### FORSIKTIG

##### Risiko for brannskader

Et kamera i bruk kan nå temperaturnivåer som kan forårsake brannskader.



#### FORSIKTIG

##### Skade ved fallende kameraer eller linser

Et fallende kamera eller en fallende linse kan forårsake skade.



#### FORSIKTIG

##### Risiko for kutt fra skarpe kanter på linsefester

Sporene på linsefestet kan ha skarpe kanter.

### Tiltenkt bruk

Den tiltenkte bruken av Allied Vision-produktet er integrering i visjonssystemer av profesjonelle. Alle Allied Vision-produkter selges i en forretning til forretning-situasjon.

## SV - Svenska

### Säkerhet

Läs igenom säkerhetsinstruktionerna innan du använder kameran. Var hela tiden särskilt uppmärksam på varningarna. Använd enbart kameran på det sätt som anges i [Intended use](#) på sida 41.



#### VARNING

##### Risk för brännskada

En kamera i drift kan komma upp i temperaturer som kan orsaka brännskador.



#### VARNING

##### Risk för skador från fallande kameror eller objektiv

Fallande kameror eller objektiv kan förorsaka skador.



#### VARNING

##### Risk för skärsår från vassa kanter på objektivfattningar

Objektivets gängor kan ha vassa kanter.

### Avsedd användning

Den avsedda användningen av Allied Vision-produkter är integrering i visionssystem av fackmän. Samtliga Allied Vision-produkter säljs i en B2B-miljö.

# ZH - 简体中文版

## 安全需知

使用本相机前，请阅读本安全说明书。请务必遵守相关警告和 [Intended use](#) 于第 41 页。



### 注意事项

#### 烫伤风险

相机操作过程中温度可能上升并导致烫伤风险。



### 注意事项

#### 相机或者镜头跌落造成伤害

相机或者镜头可能会跌落并造成伤害。



### 注意事项

#### 镜头接口的锐利边缘划伤风险

镜头接口螺纹边缘可能较为锐利。

## 预期用途

Allied Vision 产品的预期用途是由专业人士整合到视觉系统中。所有 Allied Vision 的产品均通过 B2B 渠道销售。

# Goldeye G/CL cameras at a glance



This chapter includes:

Overview .....	16
Scope of delivery .....	16
What else do you need? .....	16

## Overview



### Read this document carefully

Learn to avoid damage to your Goldeye and to use it most safely and efficiently.

This **Goldeye G/CL User Guide** describes the technical specifications and operating principle of the Goldeye camera family, including feature overview, dimensions, I/O definition, pixel formats, image processing and SWIR-specific data processing, basic and advanced parameters, and settings, as well as bandwidth and frame rate related subjects.



### Safety notes and warnings for smooth camera operation

Learn to use Goldeye cameras safely and more effectively at [Compliance, safety, and intended use](#) on page 38.



### Camera naming and labels

- Goldeye cameras are grouped in housing types called **Industrial Design** or **Scientific Design**. See [Industrial Design and Scientific Design](#) on page 34.
- Goldeye G/CL-030 TEC1 and Goldeye G/CL-130 TEC1 are named Goldeye G/CL-030 **T1** and Goldeye G/CL-130 **T1** on product labels and in all regulatory related documentation. See [Naming on product labels](#) on page 36.

## Scope of delivery

Your Goldeye camera is delivered with the following components:

- Goldeye camera
- Download Instructions for First Camera Operation

## What else do you need?

Document or software	Link
Goldeye G/CL Features Reference, camera data sheets, Modular Concept, 3D CAD STEP files	<a href="http://www.alliedvision.com/en/support/technical-documentation/goldeye-gcl-documentation">www.alliedvision.com/en/support/technical-documentation/goldeye-gcl-documentation</a>
Camera lenses and accessories	<a href="http://www.alliedvision.com/en/products/accessories">www.alliedvision.com/en/products/accessories</a>
Camera warranty duration and sensor warranty	<a href="http://www.alliedvision.com/en/support/warranty">www.alliedvision.com/en/support/warranty</a>
<b>Vimba SDK</b> including drivers and software	<a href="http://www.alliedvision.com/en/support/software-downloads">www.alliedvision.com/en/support/software-downloads</a>

Table 1: Additional resources



# Contact us

## Website, email

### General

[www.alliedvision.com/en/contact](http://www.alliedvision.com/en/contact)

[info@alliedvision.com](mailto:info@alliedvision.com)

### Distribution partners

[www.alliedvision.com/en/avt-locations/avt-distributors](http://www.alliedvision.com/en/avt-locations/avt-distributors)

### Support

[www.alliedvision.com/en/support](http://www.alliedvision.com/en/support)

[www.alliedvision.com/en/about-us/contact-us/technical-support-repair/-/rma](http://www.alliedvision.com/en/about-us/contact-us/technical-support-repair/-/rma)

## Offices

### Europe, Middle East, and Africa (Headquarters)

Allied Vision Technologies GmbH

Taschenweg 2a

07646 Stadtroda, Germany

T// +49 36428 677-0 (Reception)

T// +49 36428 677-230 (Sales)

F// +49 36428 677-28

### North, Central, and South America, Canada

Allied Vision Technologies Canada Inc.

300 – 4621 Canada Way

Burnaby, BC V5G 4X8, Canada

T// +1 604 875 8855

### USA

Allied Vision Technologies, Inc.

102 Pickering Way- Suite 502

Exton, PA 19341, USA

Toll-free// +1-877-USA-1394

T// +1 978 225 2030

### Asia-Pacific

#### China

Allied Vision Technologies Shanghai Co Ltd.

B-510, Venture International Business Park

2679 Hechuan Road

Minhang District, Shanghai 201103

People's Republic of China

T// +86 21 64861133

#### Japan

Allied Vision Technologies

Yokohama Portside Bldg. 10F

8-1 Sakae-cho, Kanagawa-ku

Yokohama-shi, Kanagawa, 221-0052

T// +81 (0) 45 577 9527

#### Singapore

Allied Vision Technologies Asia Pte. Ltd

82 Playfair Rd, #07-01 D'Lithium

Singapore 368001

T// +65 6634 9027

# Contents

Read before use	2
EN - English	2
DA - Dansk	3
DE - Deutsch	4
ES - Español	5
FI - Suomi	6
FR - Français	7
HE - עברית	8
IT - Italiano	9
JA - 日本語	10
NL - Nederlands	11
NO - Norsk	12
SV - Svenska	13
ZH - 简体中文版	14
<b>Goldeye G/CL cameras at a glance</b>	<b>15</b>
Overview	16
Scope of delivery	16
What else do you need?	16
<b>Contact us</b>	<b>17</b>
<b>Document history and conventions</b>	<b>25</b>
Document history	26
Manual conventions	32
Typographic styles	32
Symbols and notes	32
Industrial Design and Scientific Design	34
Model naming	35
Name affix for temperature control	35
Different models using the same sensor	35
Naming on product labels	36
Acronyms and terms	36
<b>Compliance, safety, and intended use</b>	<b>38</b>
Compliance notifications	39
For customers in the US	39
For customers in Canada	40
Pour utilisateurs au Canada	40
Avoid electromagnetic interferences	40
Intended use	41
Copyright and trademarks	41
Your safety	42
Handling lens mounts	42

Handling hot cameras . . . . .	42
Providing optimum heat dissipation . . . . .	42
Camera mounting . . . . .	42
Product safety . . . . .	43
Electrical connections . . . . .	43
Optical components . . . . .	44
<b>Specifications</b>	<b>46</b>
Applied standards . . . . .	47
Camera Link standard (CL models) . . . . .	47
GenICam . . . . .	47
GenCP . . . . .	47
GigE Vision (GigE models) . . . . .	47
IP class . . . . .	47
Shock and vibration . . . . .	48
Maximum and ROI frame rates . . . . .	49
Frame rates and temperature control . . . . .	50
Specifications (GigE models) . . . . .	51
Goldeye G-008 TEC1 . . . . .	51
Goldeye G-008 Cool TEC1 . . . . .	55
Goldeye G-008 XSWIR 1.9 TEC2 . . . . .	59
Goldeye G-008 XSWIR 2.2 TEC2 . . . . .	64
Goldeye G-030 TEC1 . . . . .	69
Goldeye G-032 TEC1 . . . . .	73
Goldeye G-032 Cool TEC2 . . . . .	77
Goldeye G-033 TEC1 . . . . .	81
Goldeye G-033 TECless . . . . .	85
Goldeye G-034 TEC1 . . . . .	89
Goldeye G-034 TEC2 . . . . .	93
Goldeye G-034 XSWIR 1.9 TEC2 . . . . .	97
Goldeye G-034 XSWIR 2.2 TEC2 . . . . .	102
Goldeye G-130 TEC1 . . . . .	107
Specifications (CL models) . . . . .	112
Goldeye CL-008 TEC1 . . . . .	112
Goldeye CL-008 Cool TEC1 . . . . .	117
Goldeye CL-008 XSWIR 1.9 TEC2 . . . . .	122
Goldeye CL-008 XSWIR 2.2 TEC2 . . . . .	128
Goldeye CL-030 TEC1 . . . . .	134
Goldeye CL-032 TEC1 . . . . .	139
Goldeye CL-032 Cool TEC2 . . . . .	144
Goldeye CL-033 TEC1 . . . . .	149
Goldeye CL-033 TECless . . . . .	154
Goldeye CL-034 TEC1 . . . . .	159
Goldeye CL-034 TEC2 . . . . .	164
Goldeye CL-034 XSWIR 1.9 TEC2 . . . . .	169
Goldeye CL-034 XSWIR 2.2 TEC2 . . . . .	175
Goldeye CL-130 TEC1 . . . . .	181
Technical drawings (GigE models) . . . . .	186

Model overview . . . . .	186
Goldeye G-030 TEC1, -130 TEC1: C-Mount adapter Type 2 . . . . .	187
Goldeye G-008/-034 XSWIR 1.9/2.2 TEC2, -034 TEC2: C-Mount adapter Type 2 . . . . .	188
Goldeye G-008 TEC1, -032 TEC1, -033 TEC1, -033 TECless: C-Mount adapter Type 1 . . . . .	189
Goldeye G-008 TEC1, -032 TEC1, -033 TEC1, -033 TECless: F-Mount adapter . . . . .	190
Goldeye G-008 TEC1, -032 TEC1, -033 TEC1, -033 TECless: M42-Mount adapter . . . . .	191
Goldeye G-034 TEC1: C-Mount adapter Type 1 . . . . .	192
Goldeye G-034 TEC1: F-Mount adapter . . . . .	193
Goldeye G-034 TEC1: M42-Mount adapter . . . . .	194
Goldeye G-008 Cool TEC1, -032 Cool TEC2: C-Mount adapter Type 1 . . . . .	195
Goldeye G-008 Cool TEC1, -032 Cool TEC2: F-Mount adapter . . . . .	196
Goldeye G-008 Cool TEC1, -032 Cool TEC2: M42-Mount adapter . . . . .	197
Technical drawings (CL models) . . . . .	198
Model overview . . . . .	198
Goldeye CL-030 TEC1, -130 TEC1: C-Mount adapter Type 2 . . . . .	199
Goldeye CL-008/-034 XSWIR 1.9/2.2 TEC2, -034 TEC2: C-Mount adapter Type 2 . . . . .	200
Goldeye CL-008 TEC1, -032 TEC1, -033 TEC1, -033 TECless: C-Mount adapter Type 1 . . . . .	201
Goldeye CL-008 TEC1, -032 TEC1, -033 TEC1, -033 TECless: F-Mount adapter . . . . .	202
Goldeye CL-008 TEC1, -032 TEC1, -033 TEC1, -033 TECless: M42-Mount adapter . . . . .	203
Goldeye CL-034 TEC1: C-Mount adapter Type 1 . . . . .	204
Goldeye CL-034 TEC1: F-Mount adapter . . . . .	205
Goldeye CL-034 TEC1: M42-Mount adapter . . . . .	206
Goldeye CL-008 Cool TEC1, -032 Cool TEC2: C-Mount adapter Type 1 . . . . .	207
Specifications of lens mount adapters . . . . .	208
Lens mount adapters by model . . . . .	208
Lens mount adapters: Specifications . . . . .	209
Lens mount adapters: Maximum protrusion . . . . .	209
Lens mount adapters: Ordering . . . . .	209
Sensor and mount dimensions . . . . .	211
Sensor position accuracy . . . . .	212
Camera feature availability . . . . .	213
<b>Lenses and filters . . . . .</b>	<b>214</b>
About this chapter . . . . .	215
Parameters in tables . . . . .	215
Optical vignetting with certain lenses . . . . .	215
Focal length vs. field of view . . . . .	216
Goldeye G/CL-008 models . . . . .	216
Goldeye G/CL-030 models . . . . .	216
Goldeye G/CL-032 models . . . . .	217
Goldeye G/CL-033 models . . . . .	217
Goldeye G/CL-034 models . . . . .	218
Goldeye G/CL-130 models . . . . .	218
Filter specifications . . . . .	219
General terms explained . . . . .	219
Bandpass filters . . . . .	219
<b>Accessories . . . . .</b>	<b>223</b>

Electrical connections .....	224
Power supplies .....	224
Goldeye G/CL Industrial Design models .....	224
Goldeye G/CL Scientific Design models .....	224
AC supply cables for power supplies .....	225
Hirose 4-pin power cables for Goldeye Scientific Design models .....	225
Ethernet adapters .....	226
Camera Link cables .....	226
MDR-26 to SDR-26 cables .....	226
SDR-26 to SDR-26 cables .....	227
12-pin Hirose I/O connectors and cables .....	227
Lens mount adapters .....	228
Optical filters and accessories .....	229
Filter mounting sets .....	229
Bandpass filter 1450 nm (water filter) .....	229
Filters with C-Mount adapter Type 2 .....	230
Heat sink set .....	230
<b>Installing the camera (GigE) .....</b>	<b>231</b>
Touching hot cameras .....	232
Electrostatic discharge .....	232
Mounting the camera .....	232
Mounting Industrial Design models .....	233
Mounting Scientific Design models .....	233
Front mounting for all models .....	234
Adapting maximum torque values .....	234
1/4" -20 UNC mounting thread .....	234
Mounting the lens .....	235
Configuring the host computer .....	236
Installing the NIC driver .....	237
IP settings .....	237
Optimizing system performance .....	238
Enabling jumbo packets .....	238
Connecting camera and host computer .....	239
Powering up the camera .....	239
Hardware Selection .....	240
Powering the camera via PoE .....	240
Software for your Goldeye G camera .....	241
Allied Vision software .....	241
Third-party software .....	241
Acquiring a first image .....	242
Is the camera powered? .....	242
<b>Installing the camera (CL) .....</b>	<b>243</b>
Touching hot cameras .....	244
Electrostatic discharge .....	244
Mounting the camera .....	244
Mounting Industrial Design models .....	245

Mounting Scientific Design models . . . . .	245
Front mounting for all models . . . . .	246
Adapting maximum torque values . . . . .	246
1/4" -20 UNC mounting thread . . . . .	246
Mounting the lens . . . . .	247
Installing PC hardware and software . . . . .	248
Frame grabbers . . . . .	248
Installing a frame grabber . . . . .	248
Installing camera software . . . . .	249
Connecting camera and host computer . . . . .	249
Powering up the camera . . . . .	250
Camera control and image viewing . . . . .	251
Configuring your camera . . . . .	251
Allied Vision software . . . . .	251
Third-party software . . . . .	252
Vimba with frame grabber specific viewer . . . . .	252
Using a custom application . . . . .	257
Using frame grabber transport layer . . . . .	257
Troubleshooting . . . . .	258
Is the camera getting power? . . . . .	258
Is the camera powered, but not detected in viewer? . . . . .	258
Is the camera listed in viewer, but images cannot be acquired? . . . . .	258
<b>Using lens mounts and filters . . . . .</b>	<b>259</b>
Available lens mount adapters . . . . .	260
Changing lens mount adapters . . . . .	260
Changing filters in C-Mount adapters Type 1 . . . . .	261
Changing the filter in F-Mount adapters . . . . .	263
Changing the filter in M42-Mount adapters . . . . .	264
Using C-Mount adapter Type 2 . . . . .	265
Adjusting the C-Mount . . . . .	265
Preconditions . . . . .	266
Instructions . . . . .	266
Replacing filters . . . . .	267
<b>Camera interfaces . . . . .</b>	<b>269</b>
GigE port, back panel, and status LEDs (GigE) . . . . .	270
Gigabit Ethernet port . . . . .	270
Back panel . . . . .	270
GigE status LEDs . . . . .	271
CL port, back panel, and status LED (CL) . . . . .	272
Camera Link port . . . . .	272
Back panel . . . . .	272
Camera Link status LED . . . . .	273
Power supply (GigE and CL models) . . . . .	274
Power supply via Hirose connector . . . . .	275
Power supply via Gigabit Ethernet (Goldeye G only) . . . . .	275
I/O description (GigE and CL models) . . . . .	276

I/O connectors and pin assignment .....	276
I/O definitions .....	279
Frame grabber requirements (CL) .....	287
Timing (CL) .....	288
Changing the clock frequency .....	288
Adjusting the gaps .....	289
Sequential overview .....	290
Starting the acquisition automatically (CL) .....	291
<b>Triggering</b> .....	<b>292</b>
Trigger timing diagram .....	293
Trigger definitions .....	293
Trigger rules .....	294
Trigger latencies and jitter .....	294
Goldeye models except G/CL-x30 TEC1 .....	294
Goldeye G/CL-x30 TEC1 models .....	295
<b>Image data flow</b> .....	<b>296</b>
Image data flow .....	297
Image corrections .....	298
Determination and storage of correction data .....	298
Non-uniformity correction .....	298
Background correction .....	299
Defect pixel correction .....	299
Image processing .....	300
Black level .....	300
Gain .....	300
Look-up table .....	300
Binning .....	301
Decimation .....	301
Automatic image control .....	302
Definitions .....	302
Automatic exposure control .....	305
Contrast control .....	306
Other image controls .....	309
Frame memory .....	309
Trigger-induced distortion correction .....	309
Value changes by feature interdependencies .....	311
<b>Temperature control</b> .....	<b>312</b>
How temperature affects the sensor .....	313
TEC1, TEC2, TECless .....	313
TEC1 .....	314
TEC2 .....	314
TECless .....	314
Warm-up period with TEC1 and TEC2 .....	315
Additional heating for selected models .....	315
Activating the heating of Goldeye G models .....	316

Activating the heating of the CL models . . . . .	316
Neutralization of the temperature influence . . . . .	317
Temperature setpoints . . . . .	317
Switching temperature setpoints . . . . .	319
Temperature setpoint settling time . . . . .	322
Operational statuses . . . . .	325
Features for temperature control . . . . .	326
<b>Firmware update</b>	<b>327</b>
Updating the firmware . . . . .	328
<b>Cleaning optical components</b>	<b>329</b>
Avoiding the necessity of camera cleaning . . . . .	330
Identifying contaminations . . . . .	330
Locating contaminations . . . . .	331
Removing optical filters . . . . .	331
Cleaning instructions . . . . .	332
Use of compressed air . . . . .	334
<b>Index</b>	<b>335</b>



# Document history and conventions



This chapter includes:

Document history .....	26
Manual conventions.....	32
Industrial Design and Scientific Design.....	34
Model naming .....	35
Acronyms and terms .....	36

## Document history

Version	Date	Remarks
V4.7.2	2024-Nov-07	<b>Firmware version:</b> 05.04.b71da924 Corrected typos.
V4.7.1	2024-Sep-05	<b>Release: Firmware version:</b> 05.04.b71da924 Corrected data for the housings of Goldeye G/CL-034 TEC2 models: <ul style="list-style-type: none"> <li>• Overview in <a href="#">Industrial Design and Scientific Design</a> on page 34</li> <li>• Specifications in <a href="#">Goldeye G-034 TEC2</a> on page 93 and <a href="#">Goldeye CL-034 TEC2</a> on page 164</li> <li>• Drawings in <a href="#">Technical drawings (GigE models)</a> on page 186 and <a href="#">Technical drawings (CL models)</a> on page 198</li> <li>• <a href="#">Lens mount adapters: Ordering</a> on page 209</li> <li>• Specifications in <a href="#">Lenses and filters</a> on page 214</li> <li>• Instructions in <a href="#">Using lens mounts and filters</a> on page 259.</li> </ul>
V4.7.0	2024-Aug-14	<b>Release: Firmware version:</b> 05.04.b71da924 <ul style="list-style-type: none"> <li>• Updated addresses in <a href="#">Contact us</a> on page 17.</li> <li>• Updated contents for <a href="#">Industrial Design and Scientific Design</a> on page 34 and references to this naming in the user guide.</li> <li>• Updated <a href="#">Specifications</a> on page 46:               <ul style="list-style-type: none"> <li>- <b>New models:</b> Goldeye G/CL-034 TEC2.</li> <li>- Updated QE curves for Goldeye G/CL-008 TEC1 and G/CL-008 Cool TEC1 models.</li> <li>- Updated QE curve for Goldeye G/CL-034 TEC1.</li> <li>- Added Mono16 pixel format to Goldeye G/CL-008 and G/CL034.</li> <li>- Changed reference temperature values for maximum exposure time from +25 °C to +20 °C for G/CL-032 TEC1, G/CL-033 TEC1, and G/CL-034 TEC1.</li> </ul> </li> <li>• Restructured contents in:               <ul style="list-style-type: none"> <li>- <a href="#">Specifications of lens mount adapters</a> on page 208</li> <li>- <a href="#">Lenses and filters</a> on page 214</li> <li>- <a href="#">Using lens mounts and filters</a> on page 259.</li> </ul> </li> <li>• Separated between Type 1 and Type 2 for C-Mount adapters in <a href="#">Lens mount adapters: Specifications</a> on page 209 and <a href="#">Lens mount adapters: Maximum protrusion</a> on page 209 for better overview.</li> <li>• Added <a href="#">Sensor and mount dimensions</a> on page 211.</li> <li>• Updated contents in <a href="#">IP settings</a> on page 237.</li> <li>• Corrected the description for <a href="#">Decimation</a> on page 301.</li> <li>• Applied editorial changes.</li> </ul>

Table 2: Document history (sheet 1 of 6)

Version	Date	Remarks
V4.6.2	2023-Apr-27	<p><b>Release: Firmware version:</b> 04.06.3ceb8e29</p> <ul style="list-style-type: none"> <li>Firmware version 04.06.3ceb8e29 fixes 3 bugs observed in firmware version 04.04.77cd2f3e, but does not introduce new features or changes. Therefore, data has not been changed between this and the previous version of this user guide.</li> <li>Added a note about this in <a href="#">Overview</a> on page 16.</li> <li>Reverted changes for Vimba X, because some advanced Goldeye features are not supported. Therefore, Vimba is recommended.</li> </ul>
V4.6.1	2023-Mar-27	<p><b>Firmware version:</b> 04.04.77cd2f3e</p> <ul style="list-style-type: none"> <li>Updated diagrams for relative QE with Goldeye G/CL-030 TEC1 and G/CL-130 TEC1 models in <a href="#">Specifications</a> on page 46.</li> <li>Updated contents for Vimba X with Goldeye G cameras.</li> </ul>
V4.6.0	2023-Jan-26	<p><b>Release: Firmware version:</b> 04.04.77cd2f3e</p> <ul style="list-style-type: none"> <li>Added note that lenses are not part of the product.</li> <li>Updated Hebrew contents in <a href="#">Read before use</a> on page 2.</li> <li>Updated safety notes in <a href="#">Compliance, safety, and intended use</a> on page 38 and warning messages in the other chapters of this user guide.</li> <li>Updated data for Goldeye G/CL 008 TEC1 and Goldeye G/CL-008 TEC1 Cool models in <a href="#">Specifications</a> on page 46:           <ul style="list-style-type: none"> <li>Imaging performance values</li> <li>Added 10-bit and Mono12p pixel formats</li> </ul> </li> <li><b>New models:</b> Goldeye G/CL-008 XSWIR 1.9 TEC2 and Goldeye G/CL-008 XSWIR 2.2 TEC2.</li> <li>Adjusted data for Goldeye G/CL-034 TEC1 and Goldeye G/CL-034 XSWIR models in <a href="#">Specifications</a> on page 46:           <ul style="list-style-type: none"> <li>Sensor size values</li> <li>Added Mono12p pixel format</li> </ul> </li> <li>Added <a href="#">Camera feature availability</a> on page 213.</li> <li>Added <a href="#">Focal length vs. field of view</a> on page 211.</li> <li>Updated <a href="#">Firmware update</a> on page 327.</li> <li>Applied editorial changes.</li> </ul>
V4.5.4	2022-Oct-27	<p><b>Firmware version:</b> 03.06.49d19afc</p> <p>Corrected QE curves for <a href="#">Goldeye G-034 XSWIR 2.2 TEC2</a> on page 102 and <a href="#">Goldeye CL-034 XSWIR 2.2 TEC2</a> on page 175.</p>
V4.5.3	2022-Oct-21	<p><b>Firmware version:</b> 03.06.49d19afc</p> <ul style="list-style-type: none"> <li>Corrected minimum spectral range values and updated QE curves for <a href="#">Goldeye G-034 XSWIR 1.9 TEC2</a> on page 97, <a href="#">Goldeye G-034 XSWIR 2.2 TEC2</a> on page 102, <a href="#">Goldeye CL-034 XSWIR 1.9 TEC2</a> on page 169, and <a href="#">Goldeye CL-034 XSWIR 2.2 TEC2</a> on page 175.</li> <li>Applied editorial changes.</li> </ul>

Table 2: Document history (sheet 2 of 6)

Version	Date	Remarks
V4.5.2	2022-Oct-05	<b>Firmware version:</b> 03.06.49d19afc Corrected Temporal dark noise (Gain1) values for <a href="#">Goldeye G-034 XSWIR 2.2 TEC2</a> on page 102 and <a href="#">Goldeye CL-034 XSWIR 2.2 TEC2</a> on page 175.
V4.5.1	2022-Oct-04	<b>Release: Firmware version:</b> 03.06.49d19afc <ul style="list-style-type: none"> <li>• Added Hebrew contents to <a href="#">Read before use</a> on page 2.</li> <li>• Updated data in <a href="#">Specifications</a> on page 46:               <ul style="list-style-type: none"> <li>- Added 10-bit pixel formats for Goldeye G/CL-034 TEC1</li> <li>- Goldeye G/CL-034 XSWIR 1.9 TEC2</li> <li>- Goldeye G/CL-034 XSWIR 2.2 TEC2</li> </ul> </li> <li>• Added data for Goldeye G/CL-034 XSWIR 1.9/2.2 TEC2 at various places.</li> <li>• Corrected values for temperature setpoints in <a href="#">Goldeye G-008 TEC1</a> on page 51, <a href="#">Goldeye CL-030 TEC1</a> on page 134, <a href="#">Goldeye CL-032 Cool TEC2</a> on page 144, and in <a href="#">Goldeye CL-130 TEC1</a> on page 181.</li> <li>• Applied editorial changes.</li> </ul>
V4.5.0	2022-Jun-14	<b>Firmware version:</b> 02.26.38494 <ul style="list-style-type: none"> <li>• <b>New models:</b> Added preliminary data for Goldeye G/CL-034 XSWIR 1.9 TEC2 and Goldeye G/CL-034 XSWIR 2.2 TEC2.</li> <li>• Reorganized contents in <a href="#">Temperature control</a> on page 312.</li> <li>• Editorial changes.</li> </ul>
V4.4.2	2022-Mar-08	<b>Release: Firmware version:</b> 02.26.38494 <ul style="list-style-type: none"> <li>• Added values for exposure time ranges in <i>UltraShort</i> mode for Goldeye G/CL-030 TEC1 and G/CL-130 TEC1 models in <a href="#">Specifications</a> on page 46.</li> <li>• Added separate frame rates for different acquisition modes in the specifications table for <a href="#">Goldeye G-130 TEC1</a> on page 107.</li> <li>• Added values for <a href="#">Trigger latencies and jitter</a> on page 294 with G/CL-030 TEC1 and G/CL-130 TEC1 models.</li> <li>• Added Vertical ROI and Horizontal ROI to the <a href="#">Image data flow</a> on page 297.</li> </ul>
V4.4.1	2022-Jan-21	<b>Firmware version:</b> 02.24.37527 Corrected descriptions for the ROI frame rate calculations for <a href="#">Goldeye G-130 TEC1</a> on page 107 and for <a href="#">Goldeye CL-130 TEC1</a> on page 181.
V4.4.0	2021-Nov-25	<b>Release: Firmware version:</b> 02.24.37527 <ul style="list-style-type: none"> <li>• <b>New models:</b> Goldeye CL-030 TEC1 and CL-130 TEC1</li> <li>• Updated diagrams from absolute QE to relative QE for G-030 TEC1 and G-130 TEC1 models.</li> <li>• Added Goldeye G/CL-030 TEC1 and G/CL-130 TEC1 to contents in <a href="#">Additional heating for selected models</a> on page 315.</li> <li>• Added feature descriptions for black level, gain, and decimation in <a href="#">Image processing</a> on page 300.</li> <li>• Added <a href="#">Value changes by feature interdependencies</a> on page 311.</li> </ul>

Table 2: Document history (sheet 3 of 6)

Version	Date	Remarks
V4.4.0	2021-Nov-25	<b>Firmware version:</b> 02.22.35663 <ul style="list-style-type: none"> <li>Updated feature description for binning in <a href="#">Image processing</a> on page 300.</li> <li>Editorial changes.</li> </ul>
V4.3.2	2021-Aug-13	<b>Firmware version:</b> 02.22.35663 <ul style="list-style-type: none"> <li>Added icon for compliance with UKCA in <a href="#">Compliance notifications</a> on page 39.</li> <li>Editorial changes.</li> </ul>
V4.3.1	2021-Jul-22	<b>Firmware version:</b> 02.22.35663 Editorial changes.
V4.3.0	2021-Jul-07	<b>Release: Firmware version:</b> 02.22.35663 <ul style="list-style-type: none"> <li><b>New models:</b> Goldeye G-030 TEC1 and G-130 TEC1</li> <li>Updated contents for <a href="#">Mounting the camera</a> on page 232 (for CL accordingly).</li> <li>Added contents about <a href="#">Adjusting the C-Mount</a> on page 224.</li> <li>Added contents about <a href="#">Replacing filters on models with fixed C-Mount adapter</a> on page 226.</li> <li>Added contents about <a href="#">Filters with C-Mount adapter Type 2</a> on page 230.</li> <li>Updated contents in <a href="#">Contrast control</a> on page 306.</li> <li>Editorial changes.</li> </ul>
V4.2.0	2020-Aug-12	<b>Release: Firmware version:</b> 02.20.29870 <ul style="list-style-type: none"> <li><b>New models:</b> Goldeye CL-034 TEC1 and G-034 TEC1</li> <li>Added <a href="#">Read before use</a> on page 2</li> <li>Added <a href="#">Your safety</a> on page 42</li> <li>Added <a href="#">Product safety</a> on page 43</li> <li>Updated power supply order codes</li> <li>Updated <a href="#">Installing the camera (GigE)</a> on page 231</li> <li>Updated <a href="#">Installing the camera (CL)</a> on page 243</li> <li>Editorial updates</li> </ul>
V4.1.6	2019-Sep-05	<b>Firmware version:</b> 02.18.20213 Editorial revision to improve usability
V4.1.5	2019-Jul-09	<b>Firmware version:</b> 02.18.20213 <ul style="list-style-type: none"> <li>Extended description of TID correction.</li> <li>Updated Spectral Sensitivity plots.</li> <li>Editorial changes.</li> </ul>
V4.1.4	2019-Apr-30	<b>Firmware version:</b> 02.18.20213 <ul style="list-style-type: none"> <li>Specifications: Included three Gain levels of Goldeye G/CL-033 TEC1 and TECless models.</li> <li>Upgraded the description of optical filters.</li> </ul>

Table 2: Document history (sheet 4 of 6)

Version	Date	Remarks
V4.1.3	2019-Mar-15	<b>Firmware version:</b> 02.18.20213 <ul style="list-style-type: none"> <li>Specifications: Updated power consumption data.</li> <li>Specifications: Added standards used for successful shock and vibration testing.</li> <li>Specifications: Added Gain factor to Image and Performance table.</li> <li>Accessories: Updated accessories tables.</li> </ul>
V4.1.3	2019-Mar-15	<b>Firmware version:</b> 02.18.20213 <ul style="list-style-type: none"> <li>Temperature control: Added section Recommended Environment for Goldeye TECless.</li> <li>Temperature control: Extended the section Neutralization of the Temperature Influence.</li> <li>Minor editorial changes.</li> </ul>
V4.1.2	2018-Sep-12	<b>Firmware version:</b> 02.18.20213 <ul style="list-style-type: none"> <li>Added link to application note Using the Goldeye G/CL LUT for image processing.</li> <li>Updated contact information.</li> <li>Updated installation information.</li> </ul>
V4.1.1	2018-Jul-26	Applied several editorial corrections.
V4.1.0	2018-May-08	<b>Release: Firmware version:</b> 02.18.20213 <ul style="list-style-type: none"> <li>Added functions to models Goldeye G/CL-008 TEC1 and G/CL-008 Cool TEC1:               <ul style="list-style-type: none"> <li>Modified temperature readout with increased precision (reduced <b>T_readout</b> noise).</li> <li>Ability to heat the sensor in a new mode.</li> <li>New feature <b>SensorTemperatureTargetSetpoint</b> that allows to hold one sensor temperature over a very wide range of conditions.</li> </ul> </li> </ul>
V4.0.0	2018-Mar-20	<b>Release: Firmware version:</b> 02.16.19998 <ul style="list-style-type: none"> <li><b>New models:</b> Goldeye CL-008 Cool TEC1, G-008 Cool TEC1, CL-032 Cool TEC2, CL-033 TECless, G-033 TECless.</li> <li><b>Editorial changes:</b> <ul style="list-style-type: none"> <li>Improved pin assignment description of 12-pin Hirose connector, added Hirose pin number to I/O block diagrams.</li> <li>Added the TEC level to each model name throughout the document; also added detailed description of model naming.</li> <li>Included the Installation Manual for both GigE and CL models into the Technical Manual.</li> </ul> </li> </ul>
V3.3.0	2017-Jun-14	<b>Release: Firmware version:</b> 02.14.19002 <ul style="list-style-type: none"> <li>Added automatic contrast functionality.</li> <li>Added TID correction.</li> <li>Updated formulas for maximum frame rate.</li> <li>Applied multiple small changes.</li> </ul>

Table 2: Document history (sheet 5 of 6)

Version	Date	Remarks
V3.2.0	2016-Dec-01	<b>Firmware version:</b> 02.12.17558 <ul style="list-style-type: none"> <li>• Included multiple minor updates.</li> <li>• Applied result of language check.</li> <li>• Restructured technical data and specifications .</li> </ul>
V3.1.2	2016-Nov-17	<b>Firmware version:</b> 02.12.17558 Corrected drawing of the Goldeye G-032 Cool power connector pin assignment.
V3.1.1	2016-Aug-25	<b>Firmware version:</b> 02.12.17558 Corrected formulas for frame rate calculation of Goldeye CL-032, CL-033.
V3.1.0	2016-Jun-30	<b>Release: Firmware version:</b> 02.12.17558 <ul style="list-style-type: none"> <li>• Added automatic exposure functionality.</li> <li>• Added capability to change CL timing parameters including clock frequency.</li> </ul>
V3.0.0	2016-Feb-29	<b>Release: Firmware version:</b> 2.10.16613 <b>New models:</b> Goldeye CL-008, CL-032, CL-033.
V2.0.0	2015-Aug-24	<b>Release: Firmware version:</b> 02.08.15169 <ul style="list-style-type: none"> <li>• <b>New model:</b> Goldeye G-008</li> <li>• Complete implementation of new corporate layout.</li> <li>• Introduction of look-up table and binning into the firmware.</li> </ul>
V1.3.0	2015-Mar-20	<b>Release: Firmware version:</b> 02.06.06 <ul style="list-style-type: none"> <li>• <b>New model:</b> Goldeye G-033.</li> <li>• Extended the description of image corrections.</li> </ul>
V1.2.0	2014-Nov-07	<ul style="list-style-type: none"> <li>• Updated to new brand name and new brand logo.</li> </ul>
V1.1.0	2014-Oct-24	<b>Release: Firmware version:</b> 02.04.04 <ul style="list-style-type: none"> <li>• <b>New model:</b> Goldeye G-032 Cool TEC2</li> <li>• Introduction of automatic non-uniformity correction.</li> <li>• Introduced new Resolution and ROI chapter.</li> </ul>
V1.0.0	2014-Jul-11	<b>Release: Firmware version:</b> 02.02.02 <ul style="list-style-type: none"> <li>• <b>New camera family</b>, first model: Goldeye G-032</li> <li>• First release of the document.</li> </ul>

Table 2: Document history (sheet 6 of 6)

# Manual conventions

To give this manual an easily understood layout and to emphasize important information, the following typographical styles and symbols that are used.

## Typographic styles

Style (example)	Function
<b>Emphasis</b>	Programs, or highlighting important things.
Feature names	GigE features names are displayed as monospaced text.
<i>Feature options</i>	Features options and register's options that are selectable by the user are displayed as monospaced italicized text.
UI Element	Text that is displayed, or output, by the system for the user, like parts of the GUI, dialog boxes, buttons, menus, important information, windows titles.
<a href="#">Web Reference</a>	References to other documents or webpages, like web links, hypertext links, emails, but also cross references, that include a link the user can follow by clicking.

Table 3: Typographic styles

## Symbols and notes



### CAUTION

#### Risk of burns

Precautions are described



### CAUTION

#### Injury by falling cameras or lenses

Precautions are described



### CAUTION

#### Risk of cuts by sharp edges of lens mounts

Precautions are described



### NOTICE

#### Material damage

Precautions are described.



**NOTICE****Material damage by electrostatic discharge (ESD)**

Precautions as described.

**Avoiding malfunctions**

Precautions are described.

**Practical tip**



Additional information helps to understand or ease handling the camera.

**Additional information**

Web address or reference to an external source with more information is shown.

# Industrial Design and Scientific Design

Goldeye models are available in two general housing types:

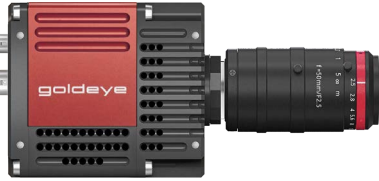
Models	Industrial Design	Scientific Design
		
Models	G/CL-008 TEC1, G/CL-032 TEC1, G/CL-033 TEC1, G/CL-033 TECless, G/CL-034 TEC1	G/CL-008 Cool TEC1, G/CL-032 Cool TEC2
Size	78 mm × 55 mm × 55 mm	90 mm × 80 mm × 80 mm
Mount options	C-Mount (adapter Type 1*), F-Mount, M42-Mount	C-Mount (adapter Type 1*), F-Mount, M42-Mount
Fan	No	Yes
Nitrogen chamber	No	Yes
Temperature control	TEC1, TEC2, or TECless	TEC1 or TEC2
		
Models	G/CL-030 TEC1, G/CL-130 TEC1	G/CL-008 XSWIR TEC2, G/CL-034 TEC2, G/CL-034 XSWIR TEC2
Size	78 mm × 55 mm × 55 mm	90 mm × 80 mm × 80 mm
Mount options	C-Mount (adapter Type 2*)	C-Mount (adapter Type 2*)
Fan	No	Yes
Nitrogen chamber	No	No
Temperature control	TEC1	TEC2

\* See [Lens mount adapters by model](#) on page 208.

Table 4: Industrial Design and Scientific Design

This user guides relates to Industrial design and Scientific Housing for better orientation.

## Model naming

In addition to family name and model name, the full designation of Goldeye models can express the temperature control or the housing as well.

Goldeye models are equipped with various active and passive temperature control devices, for example a Cool housing, or a TEC2, TEC1 or TECless sensor. These devices are not optional. Also, they are not combinable like a modular design. When present, each of them constitutes a different Goldeye model. Therefore, they reflect in the naming or name affix of the model.

### Name affix for temperature control

Goldeye models that are equipped with the same sensor may be available with different temperature controls. To make an unambiguous distinction possible, the temperature control is denoted in the model name.

Name affix	Description
TEC1	Single-stage thermo-electric temperature control
TEC2	Dual-stage thermo-electric cooling
TECless	No thermo-electric cooling available

*Table 5: Distinction between Goldeye models with various TEC stages*

See [TEC1](#), [TEC2](#), [TECless](#) on page 313 for more information.

### Different models using the same sensor

Sometimes, the same sensor is integrated in different camera models to fulfill the requirements of various applications.

**Goldeye G-032** models are available as:

- TEC1: Single-stage temperature control
- Cool TEC2: Dual-stage temperature control with fan cooling and Nitrogen chamber.

**Goldeye CL-033** models are available as:

- TEC1: Single-stage temperature control
- TECless: Passive camera cooling.

## Naming on product labels

On the label of Goldeye G/CL-130 and G/CL-030 VSWIR cameras with single-stage thermo- electric cooling (TEC1), only T1 is displayed (see Figure 1 ), as this is the official product name used in all regulatory related documentation.

Nevertheless, for convenience and to ease understanding for customers, **TEC1 is used instead of T1** in this manual and all marketing related documentation, such as data sheets, brochures, and website information.



Figure 1: Goldeye G-130 TEC1 labels - box (left), camera (right)

## Acronyms and terms

The following table provides a list of acronyms and terms used in this document.

Acronym or term	Description
ADC	Analog-to-digital converter
AIA	Automated Imaging Association
AOI	Area of interest
BC	Background correction
Bps	Bytes/s
CL	Camera Link
DPC	Defect pixel correction
DSNU	Dark signal non-uniformity
EMVA	European Machine Vision Association
ESD	Electrostatic discharge
FPA	Focal plane array
GigE	Gigabit Ethernet
GND	Ground (power)
GPIO	General purpose input and output
GVSP	GigE Vision Streaming Protocol
H × V	Horizontal × Vertical (sensor resolution measurement)
I/O	Input/Output
kΩ	Kiloohm

Table 6: Acronyms and terms used in this document (sheet 1 of 2)

<b>Acronym or term</b>	<b>Description</b>
LUT	Look-up table
MSDS	Material safety data sheet
N.a.	Not applicable (abbreviation in tables)
NIC	Network interface card
NUC	Non-uniformity correction
PoE	Power over Ethernet
PRNU	Photo response non-uniformity
PSE	Power sourcing equipment
QE	Quantum efficiency
ROI	Region of interest
SDK	Software Development Kit
TEC1	Single-stage thermo electric cooling
TEC2	Dual-stage thermo-electric cooling
TECless	No thermo-electric cooling element
TTL I/O	Transistor-transistor logic input/output
TxD and RxD	Transmit and receive
VSWIR	Visible and short-wave infrared

*Table 6: Acronyms and terms used in this document (sheet 2 of 2)*

# Compliance, safety, and intended use



This chapter includes:

Compliance notifications .....	39
Intended use .....	41
Copyright and trademarks .....	41
Your safety.....	42
Product safety .....	43

## Compliance notifications



National regulations on disposal must be followed.

### For customers in the US



#### Class B digital device

Note: This equipment has been tested and found to comply with the limits for a Class B digital device, pursuant to part 15 of the FCC Rules. These limits are designed to provide reasonable protection against harmful interference in a residential installation. This equipment generates, uses and can radiate radio frequency energy and, if not installed and used in accordance with the instructions, may cause harmful interference to radio communications. However, there is no guarantee that interference does not occur in a particular installation. If this equipment does cause harmful interference to radio or television reception, which can be determined by turning the equipment off and on, the user is encouraged to try to correct the interference by one or more of the following measures:

- Reorient or relocate the receiving antenna.
- Increase the separation between the equipment and receiver.
- Connect the equipment into an outlet on a circuit different from that to which the receiver is connected.
- Consult the dealer or an experienced radio/TV technician for help.

We caution the user that changes or modifications not expressly approved by the party responsible for compliance could void the user's authority to operate the equipment.

#### Supplier Declaration of Conformity

Goldeye G/CL cameras comply with Part 15 of the FCC Rules. Operation is subject to the following two conditions:

1. This device may not cause harmful interference, and
2. This device must accept any interference received, including interference that may cause undesired operation.

## Party issuing Supplier's Declaration of Conformity

Allied Vision Technologies GmbH  
Taschenweg 2a  
07646 Stadtroda, Germany  
T// +49 (36428) 677-106  
quality@alliedvision.com

## Responsible party - US contact information

Allied Vision Technologies, Inc.  
102 Pickering Way – Suite 502  
Exton, PA 19341, USA  
T// +1 978 225 2030

**Note:** changes or modifications not expressly approved by the party responsible for compliance could void the user's authority to operate the equipment.

## For customers in Canada

This apparatus complies with the Class B limits for radio noise emissions set out in the Radio Interference Regulations.

CAN ICES-3 (B) / NMB-3 (B)

## Pour utilisateurs au Canada

Cet appareil est conforme aux normes classe B pour bruits radioélectriques, spécifiées dans le Règlement sur le brouillage radioélectrique.

CAN ICES-3 (B) / NMB-3 (B)

## Avoid electromagnetic interferences

For all power and interface connections, only use shielded cables or cables recommended by Allied Vision.



## Intended use

Allied Vision's objective is the development, design, production, maintenance, servicing and distribution of digital cameras and components for image processing. We are offering standard products as well as customized solutions.

Intended use of Allied Vision product is the integration into Vision systems by professionals. All Allied Vision product is sold in a B2B setting.

Allied Vision isn't a legal manufacturer of medical product. Instead, Allied Vision cameras and accessories may be used as components for medical product after design-in by the medical device manufacturer and based on a quality assurance agreement (QAA) between Allied Vision (supplier) and medical device manufacturer (customer). Allied Vision's duties in that respect are defined by ISO 13485, clause 7.2 (customer-related processes, equivalent to ISO 9001, clause 8.2).

## Copyright and trademarks

All text, pictures, and graphics are protected by copyright and other laws protecting intellectual property. All content is subject to change without notice.

All trademarks, logos, and brands cited in this document are property and/or copyright material of their respective owners. Use of these trademarks, logos, and brands does not imply endorsement.

Copyright © 2024 Allied Vision GmbH. All rights reserved.

## Your safety

This section informs about issues related to your personal safety. Descriptions explain how to avoid hazards and operate Goldeye G/CL cameras safely.

### Handling lens mounts

The lens mount thread has sharp edges. Be careful these edges do not cut your skin when mounting or unmounting lenses.

### Handling hot cameras

If you hold the camera in your hands during operation, your skin may get hurt. If you touch the camera when it is heated up, we recommend wearing protective gloves.

### Providing optimum heat dissipation

Operation outside the allowed temperature range can damage the camera. For best performance and to protect the camera from damage, keep the housing temperature in the specified operating temperature range.

Observe the following:

- To avoid camera crashes, operate the camera with a lens or lens adapter attached only.
- For maximum heat dissipation, affix the camera to a heat sink, using the mounting holes.
- Use mounting base and heat sink with large surface areas.
- Use a mounting base with a high thermal conductivity.
- Reduce ambient temperature. For example, in an outdoor application with direct sunlight, provide shading by an enclosure.
- Provide ventilation or other active cooling of camera, mounting base, and heat sink.

### Camera mounting

Goldeye G/CL cameras must be mounted using the mounting threads. If vibration is higher than specified, cameras can disconnect from the mounting. Falling cameras can hurt you. To avoid personal injury:

- Mount the camera according to the instructions in the installation chapters.
- Ensure, shock and vibration do not exceed the specified range as specified in the specifications chapter.
- For heavy or long lenses, use a lens support and apply tests.

# Product safety

To prevent material damage, read the following to understand how to safely handle and operate the camera.

## Electrical connections

### ESD

ESD is dangerous for electronic devices, especially when tools or hands get in contact with connectors. We recommend measures to avoid damage by ESD:

- **Unpacking:** Remove the camera from its anti-static packaging only when your body is grounded.
- **Workplace:** Use a static-safe workplace with static-dissipative mat and air ionization.
- **Wrist strap:** Wear a static-dissipative wrist strap to ground your body.
- **Clothing:** Wear ESD-protective clothing. Keep components away from your body and clothing. Even if you are wearing a wrist strap, your body is grounded but your clothes are not.

### Cable connections

Camera Link does not support Hot Plugging, such as GigE or USB interfaces. Therefore, Goldeye CL cameras and the connected peripherals can be damaged if they are connected or disconnected improperly.

Always connect Goldeye CL cameras in the following order:

1. Connect the Camera Link cable.
2. Connect the power supply. Use only power supplies offered by Allied vision or ensure that third party equipment fulfills to the power specifications of your Goldeye CL model.

Consequently, disconnect Goldeye CL in the following order:

1. Disconnect the power supply.
2. Disconnect the Camera Link cable.

Provide sufficient strain relief for all cable connections to avoid short circuits and malfunctions.

For all power connections, use only shielded cables to avoid electromagnetic interference.

## Camera power

Operating the camera beyond the specified range damages the camera.

Cameras can be powered using the I/O connector at an input range of 12 to 24 VDC, using a limited power source (LPS), according to IEC 62368-1 with maximum 2.0 A. The camera is not intended to be connected to a DC distribution network.

Alternatively, cameras can be powered over Ethernet. However, power consumption and heat generation are higher than with external power, using the I/O connector.

- Make sure that PoE power sourcing equipment is at least compliant to IEEE 802.3af/at.
- Only use power supplies that meet the insulation requirement according to PELV or SELV. For details, please refer to IEC 61140.
- If using external power supplies by third-party manufacturers, observe polarity to avoid damage to the camera electronics.

## Optical components

Provide the following conditions to keep dirt and droplets out of the optical system of camera and lens:

- Dust-free environment
- Low relative humidity
- No condensation.

When camera or lens are stored:

- Cover the lens mount with a protection foil or cap.
- Cover front and back lens with caps.

## Sensor

Sensors are sensitive to excessive radiation: focused sunlight, UV light, lasers, and X-rays can damage the sensor. Dirt and scratches can damage the sensor as well.

Goldeye G/CL cameras do not need additional cleaning. Cameras are cleaned before shipping. Incorrect cleaning can damage the sensor or the optical filter. Therefore, only clean optical components as instructed in [Cleaning optical components](#) on page 329.

Protect the optical filter and the sensor from dirt, because dirt becomes more visible the closer it gets to the sensor. In addition, keep the back lens clean. Hold the camera with the lens mount facing the ground to keep dirt out of the lens mount.

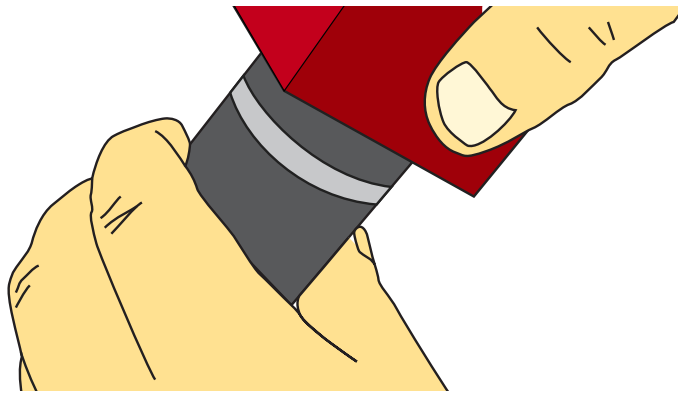

*Figure 2: Holding the camera with the lens mount facing the ground*

## Lenses

The sensor, optical filter, lens, or camera electronics can be damaged if a lens exceeding **maximum protrusion** is mounted to the camera. Use lenses with a maximum protrusion within camera specifications.

# Specifications



This chapter includes:

Applied standards .....	47
Maximum and ROI frame rates.....	49
Specifications (GigE models).....	51
Specifications (CL models) .....	112
Technical drawings (GigE models) .....	186
Technical drawings (CL models).....	198
Specifications of lens mount adapters .....	208
Sensor and mount dimensions .....	211
Sensor position accuracy .....	212
Camera feature availability .....	213

## Applied standards

### Camera Link standard (CL models)

Camera Link is a communication interface for vision applications that reduces time and costs necessary for support. Goldeye CL cameras are compliant with the Camera Link V2.0 standard. Goldeye CL cameras work with standard frame grabbers and cables.

### GenICam

GenICam is the command structure for the GigE Vision camera control. GenICam is administered by the European Machine Vision Association.

GenICam establishes a common camera control interface so that third-party software can communicate with cameras from various manufacturers without customization. It is incorporated as part of the GigE Vision standard.

### GenCP

The camera is to be controlled using the GenICam GenCP Generic Control Protocol. GenCP is packet based and it uses a virtual 64-bit address space that contains all control registers of the camera.



#### Standard document downloads

You can find document downloads for GenCP and other EMVA standards at [www.emva.org](http://www.emva.org).

### GigE Vision (GigE models)

GigE Vision is an interface standard for digital machine vision cameras, developed and maintained by the Automated Imaging Association. It is built on the Gigabit Ethernet communication protocol and widely supported in the industrial imaging industry.

### IP class

Equipped with a lens as intended, Goldeye G/CL cameras comply with

- IP40 class for **all cameras except Cool** models
- IP20 class for **Cool models only**

according to IEC 60529.

## Shock and vibration

Goldeye G/CL cameras were successfully tested for compliance with:

- IEC 60068-2-6, Sinusoidal vibration testing
- IEC 60068-2-27, Non-repetitive shock testing
- IEC 60068-2-27, Repetitive shock testing
- IEC 60068-2-64, Random vibration testing

Cameras were inspected before and after the tests. All tests were passed successfully:

Condition	Passed
Mechanics	<ul style="list-style-type: none"> <li>• The camera housings showed no deformations.</li> <li>• The connections between camera components had not come loose.</li> <li>• The sensor position was within the specified tolerances of a new camera.</li> </ul>
Camera behavior	Camera functionalities were not affected, no deviations occurred.
Image streaming	Images were streamed without errors.

Table 7: Conditions for passed tests

The conditions for cameras and lenses were the same for all tests. Solid aluminum tubes were used to represent real lenses:

Parameter	Value
Lens dummy length	45 mm
Lens dummy mass	140 g

Table 8: Conditions for lenses

## IEC 60068-2-6: Sinusoidal vibration

Frequency	Acceleration	Displacement	Tolerances	
10 Hz	Not applicable	1.5 mm	-10%	10%
58.1 Hz	Not applicable	1.5 mm		
500 Hz	200 g	Not applicable		

Table 9: Frequency, acceleration, and displacement for IEC 60068-2-6 tests

Parameter	Value
Axis <sup>1</sup>	x, y, z
Sweep rate	1 oct/min
Sweep duration per axis [hh:mm:ss]	03:45:40
Number of sweeps	40

<sup>1</sup>For technical reasons, all three axes were tested in a shaker in the upright position without a sliding table.

Table 10: Other parameters for IEC 60068-2-6 tests



## IEC 60068-2-27: Shock

Parameter	Value
Axis	x, y, z
Acceleration	50 g
Number of shocks per axis	3
Duration per axis	11 ms
Waveform	Half sine

Table 11: Parameters for IEC 60068-2-27 tests, non-repetitive

Parameter	Value
Axis	x, y, z
Acceleration	25 g
Number of shocks per axis	500
Duration per axis	6 ms
Waveform	Half sine

Table 12: Parameters for IEC 60068-2-27 tests, repetitive

## IEC 60068-2-64: Random vibration

Frequency	Acceleration
5 Hz to 500 Hz	0.05 g <sup>2</sup> /Hz

Table 13: Frequency and acceleration for IEC 60068-2-64 tests

Parameter	Value
Axis	x, y, z
Acceleration RMS (Sigma)	4.9 g
Duration per axis [hh:mm:ss]	00:30:00

Table 14: Other parameters for IEC 60068-2-64 tests

## Maximum and ROI frame rates

Frame rate values in this chapter apply to a setup using:

- Mono8 pixel format
- 115 MBps bandwidth.

If bandwidth is reduced by using `DeviceLinkThroughputLimit` or if pixel formats with a higher bit depth are used, frame rates are decreased.

**To achieve maximum frame rates...**

... for different formats, you may have to change the GigE streaming features, particularly to adjust the GigE packet size. Observe:

- Smaller packets may be advantageous if using small ROIs
- Larger packets may be advantageous if using larger ROIs

## Frame rates and temperature control

The following table displays a summary of the key sensor specifications of all Goldeye models. For more detailed information about temperature control in Goldeye cameras, refer to the section on [Temperature control](#) on page 312.

### Goldeye SWIR models

Models	Sensor	Resolution	Frame rate	Temperature control
G/CL-008 TEC1	InGaAs FPA	320 × 256	344 fps	FPA cooling and heating: TEC1, Min. $\Delta T = 20K$
G/CL-008 Cool TEC1	InGaAs FPA	320 × 256	344 fps	FPA cooling and heating: TEC1, Min. $\Delta T = 30K$
G/CL-032 TEC1	InGaAs FPA	636 × 508	100 fps	FPA cooling: TEC1, Min. $\Delta T = 30K$
G/CL-032 Cool TEC2	InGaAs FPA	636 × 508	100 fps	FPA cooling: TEC2, Min. $\Delta T = 60K$
G/CL-033 TEC1	InGaAs FPA	640 × 512	301 fps	FPA cooling: TEC1, Min. $\Delta T = 25K$
G/CL-033 TECless	InGaAs FPA	640 × 512	301 fps	Without thermo-electric cooling
G/CL-034 TEC1	InGaAs FPA	636 × 508	303 fps	FPA cooling: TEC1, Min. $\Delta T = 25k$
G/CL-034 TEC2	InGaAs FPA	636 × 508	303 fps	FPA cooling: TEC2, Min. $\Delta T = 60K$

Table 15: Goldeye SWIR models key specifications\_

### Goldeye VSWIR models

Models	Sensor	Resolution	Frame rate	Temperature control
G/CL-030 TEC1	InGaAs FPA	656 × 520	234 fps	FPA cooling: TEC1, Min. $\Delta T = 25K$
G/CL-130 TEC1	InGaAs FPA	1280 × 1024	94 fps	FPA cooling: TEC1, Min. $\Delta T = 25K$

Table 16: Goldeye VSWIR models key specifications

### Goldeye XSWIR models

Models	Sensor	Resolution	Frame rate	Temperature control
G/CL-008 XSWIR TEC2	InGaAs FPA	320 × 256	344 fps	FPA cooling: TEC2, Min. $\Delta T = 60K$
G/CL-034 XSWIR TEC2	InGaAs FPA	636 × 508	303 fps	FPA cooling: TEC2, Min. $\Delta T = 60K$

Table 17: Goldeye XSWIR models key specifications

# Specifications (GigE models)

## Goldeye G-008 TEC1

### Imaging and performance

Parameter	Values
Sensor	InGaAs, progressive scan, electronic full frame shutter
Sensor type	FPA
Spectral range	900 nm to 1700 nm
Resolution (H × V)	320 × 256
Pixel size	30 μm × 30 μm
Sensor size (effective)	9.6 mm × 7.68 mm
Dark current	880 ke <sup>-1</sup> /s <sup>1</sup>
Temporal dark noise (Gain0)	1.6 ke <sup>-1</sup>
Temporal dark noise (Gain1)	210 e <sup>-1</sup>
Saturation capacity (Gain0)	5.0 Me <sup>-1</sup>
Saturation capacity (Gain1)	170 ke <sup>-1</sup>
Dynamic range (Gain0)	70 dB <sup>1</sup>
Dynamic range (Gain1)	60 dB <sup>1</sup>
Pixel operability	>99.5%
Maximum frame rate at full resolution	344 fps
Exposure time	6 μs to 200 ms <sup>2</sup>
Temperature control	Single-stage thermo-electric cooling and heating (TEC1)
Analog gain factor	1 (Gain0), 15 (Gain1)
A/D converter	14-bit
Image buffer size	256 MB
Stream hold capacity	1524 frames at full resolution
<sup>1</sup> Typical values that were determined similar to EMVA 1288 v4.0 (Linear model) under 1200 nm LED illumination. Stated values are mean values of multiple different measurements at +25 °C FPA temperature, if not stated otherwise.	
<sup>2</sup> Maximum exposure value given is valid for Gain0 and sensor temperature of +25 °C. Even longer exposures can be set, but the image quality may deteriorate	

Table 18: Goldeye G-008 TEC1 imaging and performance

## Output

Parameter	Values
Digital interface	GigE Vision (based on IEEE 802.3 1000BASE-T)
Bit depth	8-bit to 16-bit
Pixel formats	Mono8, Mono10, Mono10p, Mono10Packed, Mono12, Mono12p, Mono12Packed, Mono14, Mono16

Table 19: Goldeye G-008 TEC1 output

## GPIOs

Parameter	Values
Opto-isolated I/Os	1 input, 2 outputs
RS232	up to 115,200 bits per second, 8N1 (adjustable)
LVTTL I/Os	1 input, 1 output

Table 20: Goldeye G-008 TEC1 GPIOs

## Mechanics

Parameter	Values
Body dimensions (L × W × H) without lens adapter	78 mm × 55 mm × 55 mm
Lens mounts	C-Mount, F-Mount, M42-Mount
Mass, body only, without adapter	320 g
Mass, with C-Mount adapter	340 g
Mass, with F-Mount adapter	390 g
Mass, with M42-Mount adapter	360 g

Table 21: Goldeye G-008 TEC1 mechanics

## Operating conditions

Parameter	Values
Operating temperature	-20 °C to +55 °C (housing)
Storage temperature	-30 °C to +70 °C (ambient)
Sensor cooling temperature, setpoints <sup>1</sup>	<ul style="list-style-type: none"> <li>+25 °C (default and calibrated)</li> <li>+20 °C, +35 °C, +50 °C (uncalibrated)</li> <li>User-configurable</li> </ul>
Relative humidity	10% to 95%, non-condensing
Power requirements (DC)	<ul style="list-style-type: none"> <li>10.8 V to 30.0 V</li> <li>PoE (IEEE 802.3at Type 1 Class 0)</li> </ul>
Maximum power consumption	<ul style="list-style-type: none"> <li>10.8 W (12 VDC)</li> <li>&lt;12.95 W (PoE)</li> </ul>
Typical power consumption without cooling	<ul style="list-style-type: none"> <li>5 W (12 VDC)</li> <li>6.5 W (PoE)</li> </ul>

<sup>1</sup> Even though the first temperature setpoint is pre-configured to +20 °C, it is possible to set it to a lower temperature. However, if the sensor temperature is lower than the ambient temperature, especially in humid environments, condensation may occur.

Table 22: Goldeye G-008 TEC1 operating conditions

## Absolute QE

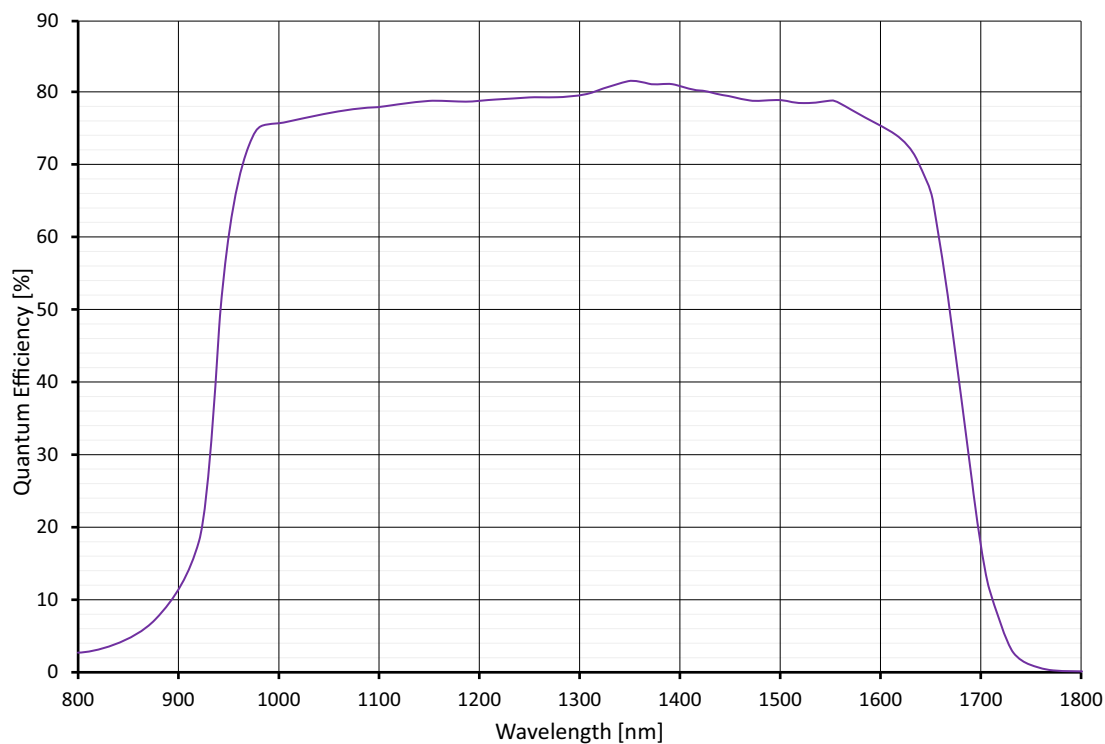

Figure 3: Goldeye G-008 TEC1 absolute QE

## Resolution and ROI frame rates

The maximum frame rate for Goldeye G-008 TEC1 is determined by the ROI size. Calculate the maximum frame rate using the following formula.

$$\text{FrameRate} = \frac{10,000,000}{\left[ (V + 2) \times \left( \frac{H}{4} + 32 \right) \right] + 171}$$

H	ROI: horizontal resolution (width). The formula is valid if $H \geq 128$ . For H always use the value rounded up to the next multiple of 8.
V	ROI: vertical resolution (height). The formula is valid if $V \geq 8$ . For V always use the value rounded up to the next multiple of 2.

When using the formula, please consider the following:

- Round the denominator down to the next full  $\mu\text{s}$ .
- Minimum ROI width is 8 pixels, minimum ROI height is 4 pixels.
- The formula generally outputs very exact values, however when the ROI approaches its minimum size, the accuracy decreases by some degree.
- Computational limitations of the host and image capture software may prevent the camera from achieving maximum frame rates.

*Formula 1: Maximum frame rate for Goldeye G-008 TEC1*

Examples for maximum frame rates with Goldeye G-008 TEC1 for common resolutions are listed in the following table.

Resolution		Remarks	Maximum frame rate [fps]
Width	Height		
320	256	Sensor full resolution	344
320	240	QVGA	366
160	120	QQVGA	1117
128	32	(None)	4273
$\leq 128$	$\leq 8$	For all resolutions smaller than this, the frame rate remains the same.	$\geq 12345$

*Table 23: Goldeye G-008 TEC1 resolution and frame rates*

## Goldeye G-008 Cool TEC1

### Imaging and performance

Parameter	Values
Sensor	InGaAs, progressive scan, electronic full frame shutter
Sensor type	FPA
Spectral range	900 nm to 1700 nm
Resolution (H × V)	320 × 256
Pixel size	30 μm × 30 μm
Sensor size (effective)	9.6 mm × 7.68 mm
Dark current	260 ke <sup>-</sup> /s <sup>1</sup>
Temporal dark noise (Gain0)	1.6 ke <sup>-</sup> <sup>1</sup>
Temporal dark noise (Gain1)	210 e <sup>-</sup> <sup>1</sup>
Saturation capacity (Gain0)	5.0 Me <sup>-</sup> <sup>1</sup>
Saturation capacity (Gain1)	170 ke <sup>-</sup> <sup>1</sup>
Dynamic range (Gain0)	70 dB <sup>1</sup>
Dynamic range (Gain1)	60 dB <sup>1</sup>
Pixel operability	>99.5%
Maximum frame rate at full resolution	344 fps
Exposure time	6 μs to 1250 ms <sup>2</sup>
Temperature control	Single-stage thermo-electric cooling and heating (TEC1)
Analog gain factor	1 (Gain0), 15 (Gain1)
A/D converter	14-bit
Image buffer size	256 MB
Stream hold capacity	1524 frames at full resolution
<sup>1</sup> Typical values that were determined similar to EMVA 1288 v4.0 (Linear model) under 1200 nm LED illumination. Stated values are mean values of multiple different measurements at +5 °C FPA temperature, if not stated otherwise.	
<sup>2</sup> Maximum exposure value given is valid for Gain0 and sensor temperature of +5 °C. Even longer exposures can be set, but the image quality may deteriorate.	

Table 24: Goldeye G-008 Cool TEC1 imaging and performance

## Output

Parameter	Values
Digital interface	GigE Vision (based on IEEE 802.3 1000BASE-T)
Bit depth	8-bit to 16-bit
Pixel formats	Mono8, Mono10, Mono10p, Mono10Packed, Mono12, Mono12p, Mono12Packed, Mono14, Mono16

Table 25: Goldeye G-008 Cool TEC1 output

## GPIOs

Parameter	Values
Opto-isolated I/Os	1 input, 2 outputs
RS232	up to 115,200 bits per second, 8N1 (adjustable)
LVTTL I/Os	1 input, 1 output

Table 26: Goldeye G-008 Cool TEC1 GPIOs

## Mechanics

Parameter	Values
Body dimensions (L × W × H) without lens adapter	90 mm × 80 mm × 80 mm
Lens mounts	<ul style="list-style-type: none"> <li>C-Mount</li> <li>F-Mount and M42-Mount available on request</li> </ul>
Mass, body only, without adapter	770 g
Mass, with C-Mount adapter	790 g
Mass, with F-Mount adapter	840 g
Mass, with M42-Mount adapter	810 g

Table 27: Goldeye G-008 Cool TEC1 mechanics



## Operating conditions

Parameter	Values
Operating temperature	-20 °C to +55 °C (housing)
Storage temperature	-30 °C to +70 °C (ambient)
Sensor cooling temperature, setpoints	<ul style="list-style-type: none"> <li>• +5 °C (default and calibrated)</li> <li>• -5 °C, +10 °C, +20 °C (uncalibrated)</li> <li>• User-configurable</li> </ul>
Relative humidity	10% to 95%, non-condensing
Power requirements (DC)	<ul style="list-style-type: none"> <li>• 10.8 V to 30.0 V</li> <li>• PoE (IEEE 802.3at Type 1 Class 0)</li> </ul>
Maximum power consumption	<ul style="list-style-type: none"> <li>• 10.7 W (12 VDC)</li> <li>• &lt;12.95 W (PoE)</li> </ul>
Typical power consumption without cooling	<ul style="list-style-type: none"> <li>• 4.9 W (12 VDC)</li> <li>• 6.6 W (PoE)</li> </ul>

Table 28: Goldeye G-008 Cool TEC1 operating conditions

## Absolute QE

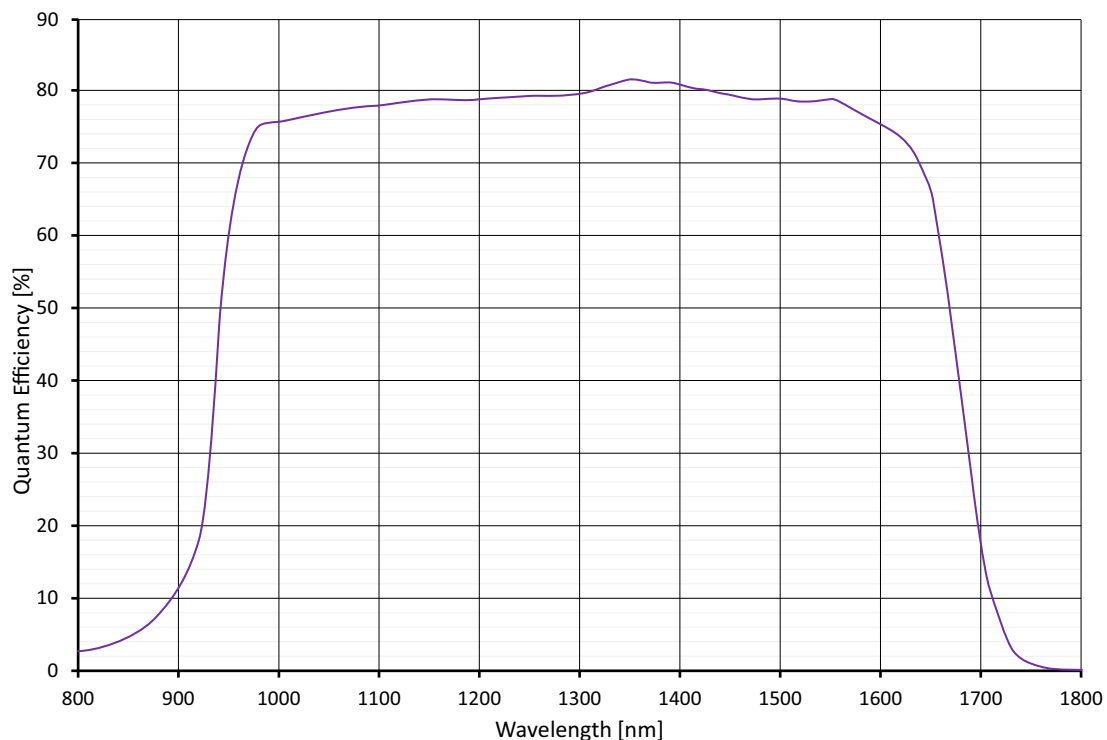

Figure 4: Goldeye G-008 Cool TEC1 absolute QE

## Resolution and ROI frame rates

The maximum frame rate for Goldeye G-008 Cool TEC1 is determined by the ROI size. Calculate the maximum frame rate using the following formula.

$$\text{FrameRate} = \frac{10,000,000}{\left[ (V + 2) \times \left( \frac{H}{4} + 32 \right) \right] + 171}$$

H	ROI: horizontal resolution (width). The formula is valid if $H \geq 128$ . For H always use the value rounded up to the next multiple of 8.
V	ROI: vertical resolution (height). The formula is valid if $V \geq 8$ . For V always use the value rounded up to the next multiple of 2.

When using the formula, please consider the following:

- Round the denominator down to the next full  $\mu\text{s}$ .
- Minimum ROI width is 8 pixels, minimum ROI height is 4 pixels.
- The formula generally outputs very exact values, however when the ROI approaches its minimum size, the accuracy decreases by some degree.
- Computational limitations of the host and image capture software may prevent the camera from achieving maximum frame rates.

*Formula 2: Maximum frame rate for Goldeye G-008 Cool TEC1*

Examples for maximum frame rates with Goldeye G-008 Cool TEC1 for common resolutions are listed in the following table.

Resolution		Format name	Maximum frame rate [fps]
Width	Height		
320	256	Sensor full resolution	344
320	240	QVGA	366
160	120	QQVGA	1117
128	32	(None)	4273
$\leq 128$	$\leq 8$	For all resolutions smaller than this, the frame rate remains the same.	$\geq 12345$

*Table 29: Goldeye G-008 Cool TEC1 resolution and frame rates*

## Goldeye G-008 XSWIR 1.9 TEC2

### Imaging and performance

Parameter	Values
Sensor	InGaAs, progressive scan, electronic full frame shutter
Sensor type	FPA
Spectral range	1100 nm to 1900 nm
Resolution (H × V)	320 × 256
Pixel size	30 μm × 30 μm
Sensor size (effective)	9.6 mm × 7.68 mm
Dark current	1.2 Me <sup>-</sup> /s <sup>1</sup>
Temporal dark noise (Gain0)	1.8 ke <sup>-</sup> <sup>1</sup>
Temporal dark noise (Gain1)	200 e <sup>-</sup> <sup>1</sup>
Saturation capacity (Gain0)	5.0 Me <sup>-</sup> <sup>1</sup>
Saturation capacity (Gain1)	140 ke <sup>-</sup> <sup>1</sup>
Dynamic range (Gain0)	68 dB <sup>1</sup>
Dynamic range (Gain1)	57 dB <sup>1</sup>
Pixel operability	>98.5%
Maximum frame rate at full resolution	344 fps
Exposure time	6 μs to 30 ms <sup>2</sup>
Temperature control	Dual-stage thermo-electric cooling (TEC2)
Analog gain factor	1 (Gain0), 15 (Gain1)
A/D converter	14-bit
Image buffer size	256 MB
Stream hold capacity	1524 frames at full resolution
<sup>1</sup> Typical values that were determined similar to EMVA 1288 v4.0 (Linear model) under 1200 nm LED illumination. Stated values are mean values of multiple different measurements at -30 °C FPA temperature, if not stated otherwise.	
<sup>2</sup> Maximum exposure value given is valid for Gain0 and sensor temperature of -30 °C. Even longer exposures can be set, but the image quality may deteriorate.	

Table 30: Goldeye G-008 XSWIR 1.9 TEC2 imaging and performance

## Output

Parameter	Values
Digital interface	GigE Vision (based on IEEE 802.3 1000BASE-T)
Bit depth	8-bit to 16-bit
Pixel formats	Mono8, Mono10, Mono10p, Mono10Packed, Mono12, Mono12p, Mono12Packed, Mono14, Mono16

Table 31: Goldeye G-008 XSWIR 1.9 TEC2 output

## GPIOs

Parameter	Values
Opto-isolated I/Os	1 input, 2 outputs
RS232	up to 115,200 bits per second, 8N1 (adjustable)
LVTTL I/Os	1 input, 1 output

Table 32: Goldeye G-008 XSWIR 1.9 TEC2 GPIOs

## Mechanics

Parameter	Values
Body dimensions (L × W × H) without lens mount adapter	90 mm × 80 mm × 80 mm
Lens mount	C-Mount
Mass, including lens mount	740 g

Table 33: Goldeye G-008 XSWIR 1.9 TEC2 mechanics

## Operating conditions

Parameter	Values
Operating temperature	-20 °C to +55 °C (housing)
Storage temperature	-30 °C to +70 °C (ambient)
Sensor cooling temperature, setpoints	<ul style="list-style-type: none"> <li>• -30°C (default and calibrated)</li> <li>• -20 °C (calibrated)</li> <li>• -10 °C, 0 °C (uncalibrated)</li> <li>• User-configurable</li> </ul>
Relative humidity	10% to 95%, non-condensing
Power requirements (DC)	<ul style="list-style-type: none"> <li>• 10.8 V to 30.0 V</li> <li>• PoE+ (IEEE 802.3at Type 2 Class 4)</li> </ul>
Maximum power consumption	<ul style="list-style-type: none"> <li>• 20 W (12 VDC)</li> <li>• &lt;21 W (PoE)</li> </ul>
Typical power consumption without cooling	<ul style="list-style-type: none"> <li>• 5 W (12 VDC)</li> <li>• 7 W (PoE)</li> </ul>

*Table 34: Goldeye G-008 XSWIR 1.9 TEC2 operating conditions*

## Absolute QE



### Quantum efficiency for various sensor temperature values

The following curves relate to a sensor temperatures of -20 °C and -30 °C default, the sensitivity is slightly shifted to lower wave lengths, but the range is maintained. With increased sensor temperatures, the QE curve is slightly shifted to longer wavelengths, and for lower temperatures it is shifted to shorter wavelengths.

See the corresponding application note at [www.alliedvision.com/fileadmin/content/documents/products/cameras/Goldeye\\_2/appnote/Goldeye-G-CL\\_AppNote\\_Temperature-Influence-on-Image-Quality\\_en.pdf](http://www.alliedvision.com/fileadmin/content/documents/products/cameras/Goldeye_2/appnote/Goldeye-G-CL_AppNote_Temperature-Influence-on-Image-Quality_en.pdf).

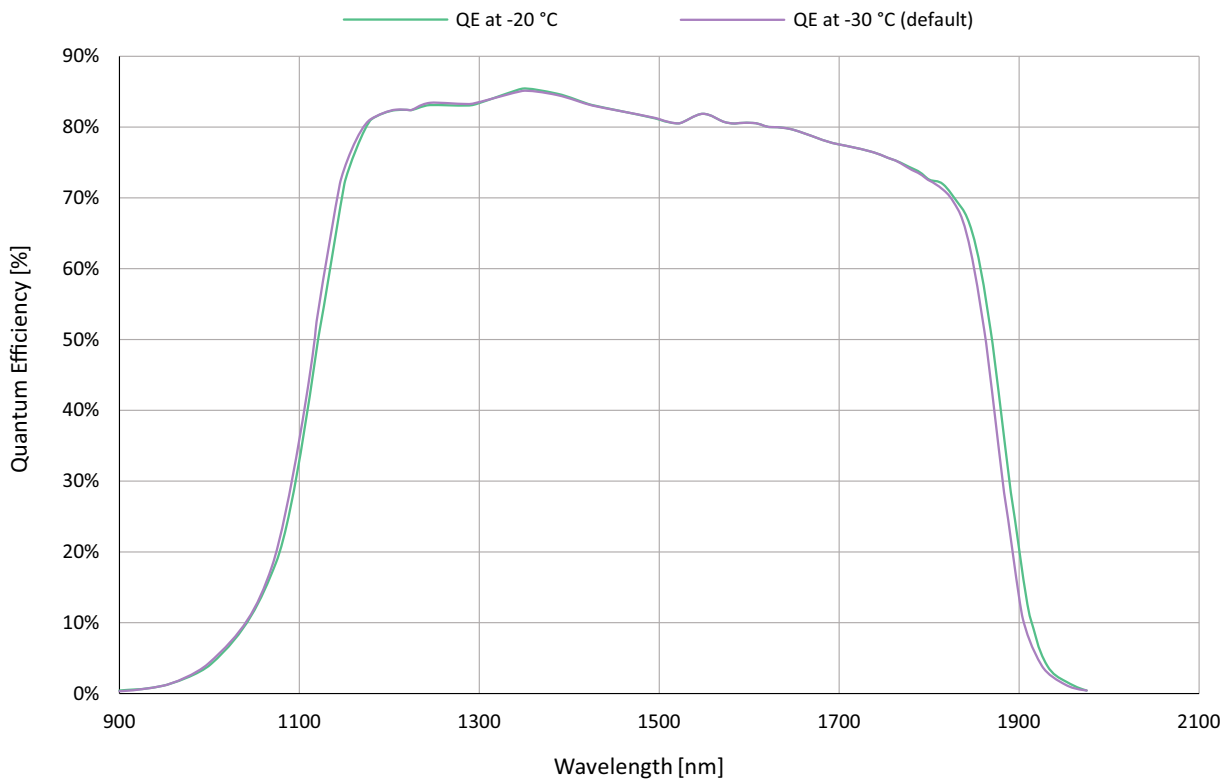

Figure 5: Goldeye G-008 XSWIR 1.9 TEC2 absolute QE

## Resolution and ROI frame rate



### Values when using MultiRegions features

When the camera is operated using more than a single ROI, values in this section may not be reached.

The maximum frame rate for Goldeye G-008 XSWIR 1.9 TEC2 is determined by the ROI size. Calculate the maximum frame rate using the following formula.

$$\text{FrameRate} = \frac{18,000,000}{\left[ (V + 1) \times \left( \frac{H}{8} + 36 \right) \right] + 254}$$

H	ROI: horizontal resolution (width). The formula is valid if $H \geq 32$ . For H always use the value rounded up to the next multiple of multiple of 32.
V	ROI: vertical resolution (height). The formula is valid if $V \geq 4$ . For V always use the value rounded up to the next multiple of 4.

When using the formula, please consider the following:

- Round the denominator up or down to the next full  $\mu\text{s}$ .
- Minimum ROI width is 8 pixels, minimum ROI height is 4 pixels.
- The formula generally outputs very exact values, however when the ROI approaches its minimum size, the accuracy decreases by some degree.
- Computational limitations of the host and image capture software may prevent the camera from achieving maximum frame rates.

*Formula 3: Maximum frame rate for Goldeye G-008 XSWIR 1.9 TEC2*

Examples for maximum frame rates with Goldeye G-008 XSWIR 1.9 TEC2 for common resolutions are listed in the following table.

Resolution		Remarks	Maximum frame rate [fps]
Width	Height		
320	256	Sensor full resolution	344
320	240	QVGA	366
160	120	QQVGA	1117
128	32	(None)	4260
$\leq 128$	$\leq 8$	For all resolutions smaller than this, the frame rate remains the same.	$\geq 4482$ <sup>1</sup> $12345$ <sup>2</sup>

<sup>1</sup> Measurement Parameters: ExposureTime = 6 $\mu\text{s}$ , IntegrationMode = IWR, DevicethroughputLimit = 115000000 (default value), all other settings are default.

<sup>2</sup> Only for AcquisitionMode = Recorder, DeviceLinkThroughputLimitMode = Off, ExposureTime = 6 $\mu\text{s}$ , IntegrationMode = IWR

*Table 35: Goldeye G-008 XSWIR 1.9 TEC2 resolution and frame rates*

## Goldeye G-008 XSWIR 2.2 TEC2

### Imaging and performance

Parameter	Values
Sensor	InGaAs, progressive scan, electronic full frame shutter
Sensor type	FPA
Spectral range	1200 nm to 2200 nm
Resolution (H × V)	320 × 256
Pixel size	30 μm × 30 μm
Sensor size (effective)	9.6 mm × 7.68 mm
Dark current	15.3 Me <sup>-</sup> /s <sup>1</sup>
Temporal dark noise (Gain0)	2.5 ke <sup>-</sup> <sup>1</sup>
Temporal dark noise (Gain1)	200 e <sup>-</sup> <sup>1</sup>
Saturation capacity (Gain0)	5.0 Me <sup>-</sup> <sup>1</sup>
Saturation capacity (Gain1)	110 ke <sup>-</sup> <sup>1</sup>
Dynamic range (Gain0)	68 dB <sup>1</sup>
Dynamic range (Gain1)	57 dB <sup>1</sup>
Pixel operability	>98.5%
Maximum frame rate at full resolution	344 fps
Exposure time	6 μs to 7 ms <sup>2</sup>
Temperature control	Dual-stage thermo-electric cooling (TEC2)
Analog gain factor	1 (Gain0), 15 (Gain1)
A/D converter	14-bit
Image buffer size	256 MB
Stream hold capacity	1524 frames at full resolution
<sup>1</sup> Typical values that were determined similar to EMVA 1288 v4.0 (Linear model) under 1485 nm LED illumination. Stated values are mean values of multiple different measurements at -30 °C FPA temperature, if not stated otherwise.	
<sup>2</sup> Maximum exposure value given is valid for Gain0 and sensor temperature of -30 °C. Even longer exposures can be set, but the image quality may deteriorate.	

Table 36: Goldeye G-008 XSWIR 2.2 TEC2 imaging and performance



## Output

Parameter	Values
Digital interface	GigE Vision (based on IEEE 802.3 1000BASE-T)
Bit depth	8-bit to 16-bit
Pixel formats	Mono8, Mono10, Mono10p, Mono10Packed, Mono12, Mono12p, Mono12Packed, Mono14, Mono16

*Table 37: Goldeye G-008 XSWIR 2.2 TEC2 XSWIR 1.9 TEC2 output*

## GPIOs

Parameter	Values
Opto-isolated I/Os	1 input, 2 outputs
RS232	up to 115,200 bits per second, 8N1 (adjustable)
LVTTL I/Os	1 input, 1 output

*Table 38: Goldeye G-008 XSWIR 2.2 TEC2 XSWIR 1.9 TEC2 GPIOs*

## Mechanics

Parameter	Values
Body dimensions (L × W × H) without lens mount adapter	90 mm × 80 mm × 80 mm
Lens mount	C-Mount
Mass, including lens mount	740 g

*Table 39: Goldeye G-008 XSWIR 2.2 TEC2 XSWIR 1.9 TEC2 mechanics*

## Operating conditions

Parameter	Values
Operating temperature	-20 °C to +55 °C (housing)
Storage temperature	-30 °C to +70 °C (ambient)
Sensor cooling temperature, setpoints	<ul style="list-style-type: none"> <li>• -30 °C (default and calibrated)</li> <li>• -20 °C, -10 °C, 0 °C (uncalibrated)</li> <li>• User-configurable</li> </ul>
Relative humidity	10% to 95%, non-condensing
Power requirements (DC)	<ul style="list-style-type: none"> <li>• 10.8 V to 30.0 V</li> <li>• PoE+ (IEEE 802.3at Type 2 Class 4)</li> </ul>
Maximum power consumption	<ul style="list-style-type: none"> <li>• 21 W (12 VDC)</li> <li>• &lt;23 W (PoE)</li> </ul>
Typical power consumption without cooling	<ul style="list-style-type: none"> <li>• 7 W (12 VDC)</li> <li>• 9 W (PoE)</li> </ul>

Table 40: Goldeye G-008 XSWIR 2.2 TEC2 XSWIR 1.9 TEC2 operating conditions

## Absolute QE



### Quantum efficiency for various sensor temperature values

The following curves relate to a sensor temperatures of -20 °C and -30 °C default, the sensitivity is slightly shifted to lower wave lengths, but the range is maintained. With increased sensor temperatures, the QE curve is slightly shifted to longer wavelengths, and for lower temperatures it is shifted to shorter wavelengths.

See the corresponding application note at [www.alliedvision.com/fileadmin/content/documents/products/cameras/Goldeye\\_2/appnote/Goldeye-G-CL\\_AppNote\\_Temperature-Influence-on-Image-Quality\\_en.pdf](http://www.alliedvision.com/fileadmin/content/documents/products/cameras/Goldeye_2/appnote/Goldeye-G-CL_AppNote_Temperature-Influence-on-Image-Quality_en.pdf).

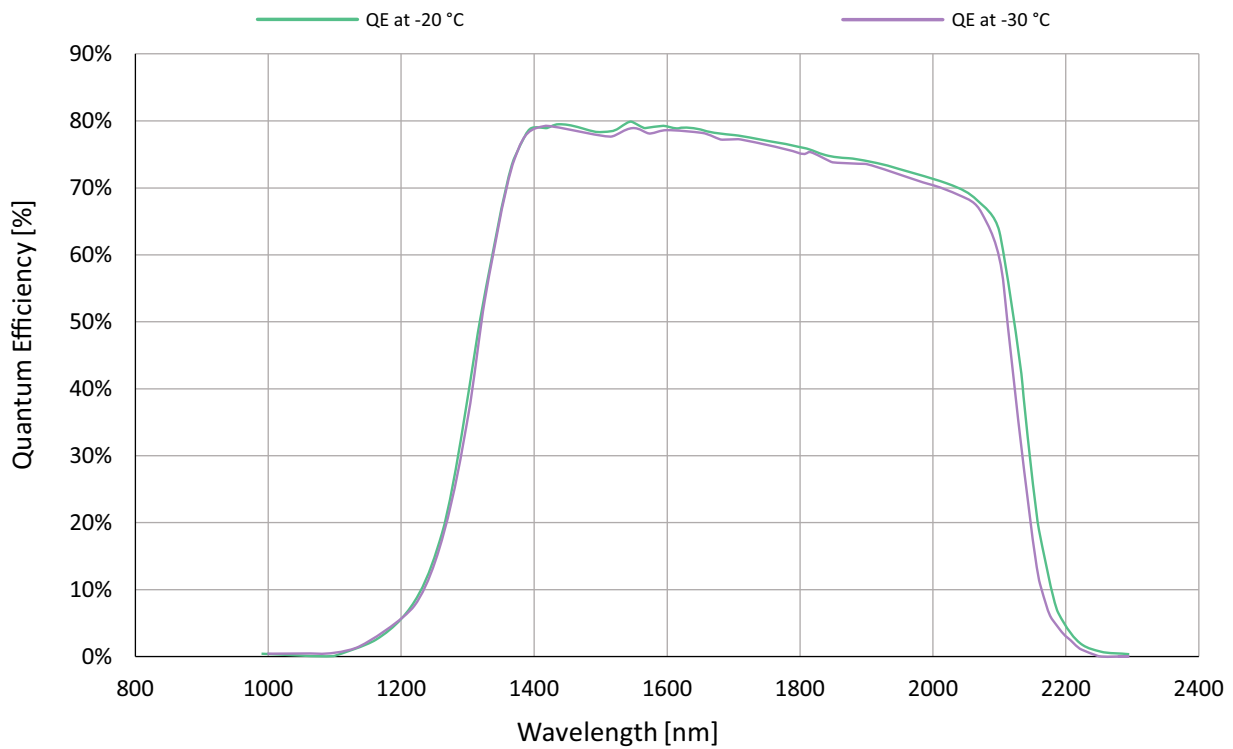

Figure 6: Goldeye G-008 XSWIR 2.2 TEC2 XSWIR 1.9 TEC2 absolute QE

## Resolution and ROI frame rate



### Values when using MultiRegions features

When the camera is operated using more than a single ROI, values in this section may not be reached.

The maximum frame rate for Goldeye G-008 XSWIR 2.2 TEC2 is determined by the ROI size. Calculate the maximum frame rate using the following formula.

$$\text{FrameRate} = \frac{18,000,000}{\left[ (V + 1) \times \left( \frac{H}{8} + 36 \right) \right] + 254}$$

H	ROI: horizontal resolution (width). The formula is valid if H ≥ 32. For H always use the value rounded up to the next multiple of multiple of 32.
V	ROI: vertical resolution (height). The formula is valid if V ≥ 4. For V always use the value rounded up to the next multiple of 4.

When using the formula, please consider the following:

- Round the denominator up or down to the next full μs.
- Minimum ROI width is 8 pixels, minimum ROI height is 4 pixels.
- The formula generally outputs very exact values, however when the ROI approaches its minimum size, the accuracy decreases by some degree.
- Computational limitations of the host and image capture software may prevent the camera from achieving maximum frame rates.

*Formula 4: Maximum frame rate for Goldeye G-008 XSWIR 2.2 TEC2*

Examples for maximum frame rates with Goldeye G-008 XSWIR 2.2 TEC2 XSWIR 1.9 TEC2 for common resolutions are listed in the following table..

Resolution		Remarks	Maximum frame rate [fps]
Width	Height		
320	256	Sensor full resolution	344
320	240	QVGA	366
160	120	QQVGA	1117
128	32	(None)	4260
≤ 128	≤ 8	For all resolutions smaller than this, the frame rate remains the same.	≥ 4482 <sup>1</sup> 12345 <sup>2</sup>

<sup>1</sup> Measurement Parameters: ExposureTime = 6μs, IntegrationMode = IWR, DevicethroughputLimit = 115000000 (default value), all other settings are default.

<sup>2</sup> Only for AcquisitionMode = Recorder, DeviceLinkThroughputLimitMode = Off, ExposureTime = 6μs, IntegrationMode = IWR

*Table 41: Goldeye G-008 XSWIR 2.2 TEC2 resolution and frame rates*

## Goldeye G-030 TEC1

### Imaging and performance

Parameter	Values
Sensor model	Sony IMX991 SenSWIR
Sensor type	InGaAs
Sensor format	Type 1/4 (4.1 mm diagonal)
Shutter type	Global shutter
Spectral range	400 nm to 1700 nm
Resolution (H × V)	656 × 520
Pixel size	5 μm × 5 μm
Sensor size (effective)	3.28 mm × 2.6 mm
Dark current (at +20 °C FPA temperature)	4.8 ke <sup>-</sup> /s
Temporal dark noise (0 dB)	250 e <sup>-</sup>
Temporal dark noise (18 dB)	210 e <sup>-</sup>
Saturation capacity (0 dB)	165 ke <sup>-</sup>
Saturation capacity (18 dB)	17.2 ke <sup>-</sup>
Dynamic range (0 dB)	56.4 dB
Dynamic range (18 dB)	38.2 dB
Pixel operability	>99.5%
Exposure time	16 μs to 200 ms <sup>1</sup> (Normal <sup>2</sup> )   3 μs to 7 μs (Ultrashort <sup>2</sup> )
Maximum frame rate at full resolution	234 fps
Temperature control	Single-stage thermo-electric cooling (TEC1)
Analog gain factor	1 (0 dB), 7.9 (18 dB)
A/D converter	12-bit
Image buffer size	256 MB
Stream hold capacity	370 frames at full resolution
<sup>1</sup> Maximum exposure value given is valid for 0 dB and sensor temperature of +20 °C. Even longer exposures can be set, but the image quality may deteriorate.	
<sup>2</sup> Values for ExposureRangeMode = <i>Normal</i> or <i>Ultrashort</i>	

Table 42: Goldeye G-030 TEC1 imaging and performance

## Output

Parameter	Values
Digital interface	GigE Vision (based on IEEE 802.3 1000BASE-T)
Bit depth	8-bit to 12-bit
Pixel formats	Mono8, Mono12, Mono12Packed

*Table 43: Goldeye G-030 TEC1 output*

## GPIOs

Parameter	Values
Opto-isolated I/Os	1 input, 2 outputs
RS232	up to 115,200 bits per second, 8N1 (adjustable)
LVTTL I/Os	1 input, 1 output

*Table 44: Goldeye G-030 TEC1 GPIOs*

## Mechanics

Parameter	Values
Body dimensions (L × W × H) without lens mount adapter	78 mm × 55 mm × 55 mm
Lens mount	C-Mount
Mass, including lens mount	340 g

*Table 45: Goldeye G-030 TEC1 mechanics*

## Operating conditions

Parameter	Values
Operating temperature	-20 °C to +55 °C (housing)
Storage temperature	-30 °C to +70 °C (ambient)
Sensor cooling temperature, setpoints	<ul style="list-style-type: none"> <li>+20 °C (default and calibrated)</li> <li>+5 °C, +35 °C, +50 °C (uncalibrated)</li> <li>User-configurable</li> </ul>
Relative humidity	10% to 95%, non-condensing
Power requirements (DC)	<ul style="list-style-type: none"> <li>10.8 V to 30.0 V</li> <li>PoE (IEEE 802.3at Type 1 Class 0)</li> </ul>
Maximum power consumption	<ul style="list-style-type: none"> <li>10.8 W (12 VDC)</li> <li>&lt;12.95 W (PoE)</li> </ul>
Typical power consumption without cooling	<ul style="list-style-type: none"> <li>5.6 W (12 VDC)</li> <li>7.2 W (PoE)</li> </ul>

Table 46: Goldeye G-030 TEC1 operating conditions

## Relative QE

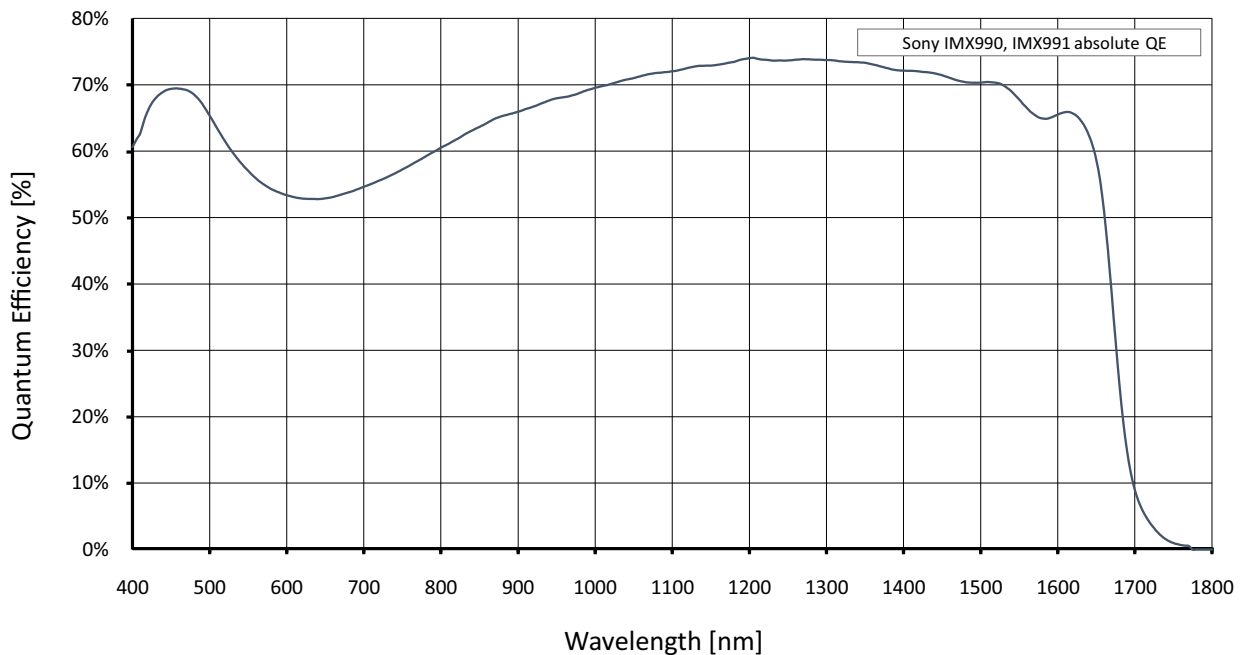

Figure 7: Goldeye G-030 TEC1 relative QE

## Resolution and ROI frame rates

The maximum frame rate for Goldeye G-030 TEC1 is determined by the ROI size. Calculate the maximum frame rate using the following formula.

$$\text{SensorFrameRate} = \frac{\text{PF}}{V + 36}$$

PF	Pixel format factor <ul style="list-style-type: none"> <li>• Mono8: 130208.33</li> <li>• Mono12: 75604.84</li> <li>• Mono12p: 75604.84</li> </ul>
V	ROI: vertical resolution (height). The formula is valid if $V \geq 8$ . For V always use the value rounded up to the next multiple of 8.

When using the formula, please consider the following:

- The formula serves as a rough estimation.
- Valid for IntegrateWhileRead-Mode only.
- ROI minimum width and height are 8 pixels.
- Exposure time may reduce the frame rate.
- Computational limitations of the host and image capture software may prevent the camera from achieving maximum frame rates.

*Formula 5: Maximum frame rate for Goldeye G-030 TEC1*

Examples for maximum frame rates with Goldeye G-030 TEC1 for common resolutions are listed in the following table.

Resolution		Format name	Maximum frame rate [fps]
Width	Height		
656	520	Sensor full resolution	234
640	480	VGA	252
320	240	QVGA	471
160	120	QQVGA	834
656	260	Maximum × half	439
656	8	Maximum × minimum	2959
8	520	Minimum × maximum	234
8	8	Minimum × minimum	2959

*Table 47: Goldeye G-030 TEC1 resolution and frame rates*



## Goldeye G-032 TEC1

### Imaging and performance

Parameter	Values
Sensor	InGaAs, progressive scan, electronic full frame shutter
Sensor type	FPA
Spectral range	900 nm to 1700 nm
Resolution (H × V)	636 × 508
Pixel size	25 μm × 25 μm
Sensor size (effective)	15.9 mm × 12.7 mm
Dark current (at +20 °C FPA temperature)	380 ke <sup>-</sup> /s
Temporal dark noise (Gain0)	400 e <sup>-</sup>
Temporal dark noise (Gain1)	170 e <sup>-</sup>
Saturation capacity (Gain0)	1.9 Me <sup>-</sup>
Saturation capacity (Gain1)	39 ke <sup>-</sup>
Dynamic range (Gain0)	73 dB
Dynamic range (Gain1)	47 dB
Pixel operability	>99.5%
Exposure time	6 μs to 200 ms <sup>1</sup>
Maximum frame rate at full resolution	100 fps
Temperature control	Single-stage thermo-electric cooling (TEC1)
Analog gain factor	1 (Gain0), 50 (Gain1)
A/D converter	14-bit
Image buffer size	256 MB
Stream hold capacity	397 frames at full resolution
<sup>1</sup> Maximum exposure value given is valid for Gain0 and sensor temperature of +20 °C. Even longer exposures can be set, but the image quality may deteriorate.	

Table 48: Goldeye G-032 TEC1 imaging and performance

## Output

Parameter	Values
Digital interface	GigE Vision (based on IEEE 802.3 1000BASE-T)
Bit depth	8-bit to 14-bit
Pixel formats	Mono8, Mono12, Mono12Packed, Mono14

*Table 49: Goldeye G-032 TEC1 output*

## GPIOs

Parameter	Values
Opto-isolated I/Os	1 input, 2 outputs
RS232	up to 115,200 bits per second, 8N1 (adjustable)
LVTTL I/Os	1 input, 1 output

*Table 50: Goldeye G-032 TEC1 GPIOs*

## Mechanics

Parameter	Values
Body dimensions (L × W × H) without lens adapter	78 mm × 55 mm × 55 mm
Lens mounts	C-Mount, F-Mount, M42-Mount
Mass, body only, without adapter	350 g
Mass, with C-Mount adapter	370 g
Mass, with F-Mount adapter	420 g
Mass, with M42-Mount adapter	390 g

*Table 51: Goldeye G-032 TEC1 mechanics*

## Operating conditions

Parameter	Values
Operating temperature	-20 °C to +55 °C (housing)
Storage temperature	-30 °C to +70 °C (ambient)
Sensor cooling temperature, setpoints	<ul style="list-style-type: none"> <li>• +20 °C (default and calibrated)</li> <li>• +5 °C, +35 °C, +50 °C (uncalibrated)</li> <li>• User-configurable</li> </ul>
Relative humidity	10% to 95%, non-condensing
Power requirements (DC)	<ul style="list-style-type: none"> <li>• 10.8 V to 30.0 V</li> <li>• PoE (IEEE 802.3at Type 1 Class 0)</li> </ul>
Maximum power consumption	<ul style="list-style-type: none"> <li>• 10.8 W (12 VDC)</li> <li>• &lt;12.95 W (PoE)</li> </ul>
Typical power consumption without cooling	<ul style="list-style-type: none"> <li>• 5 W (12 VDC)</li> <li>• 6.5 W (PoE)</li> </ul>

Table 52: Goldeye G-032 TEC1 operating conditions

## Absolute QE

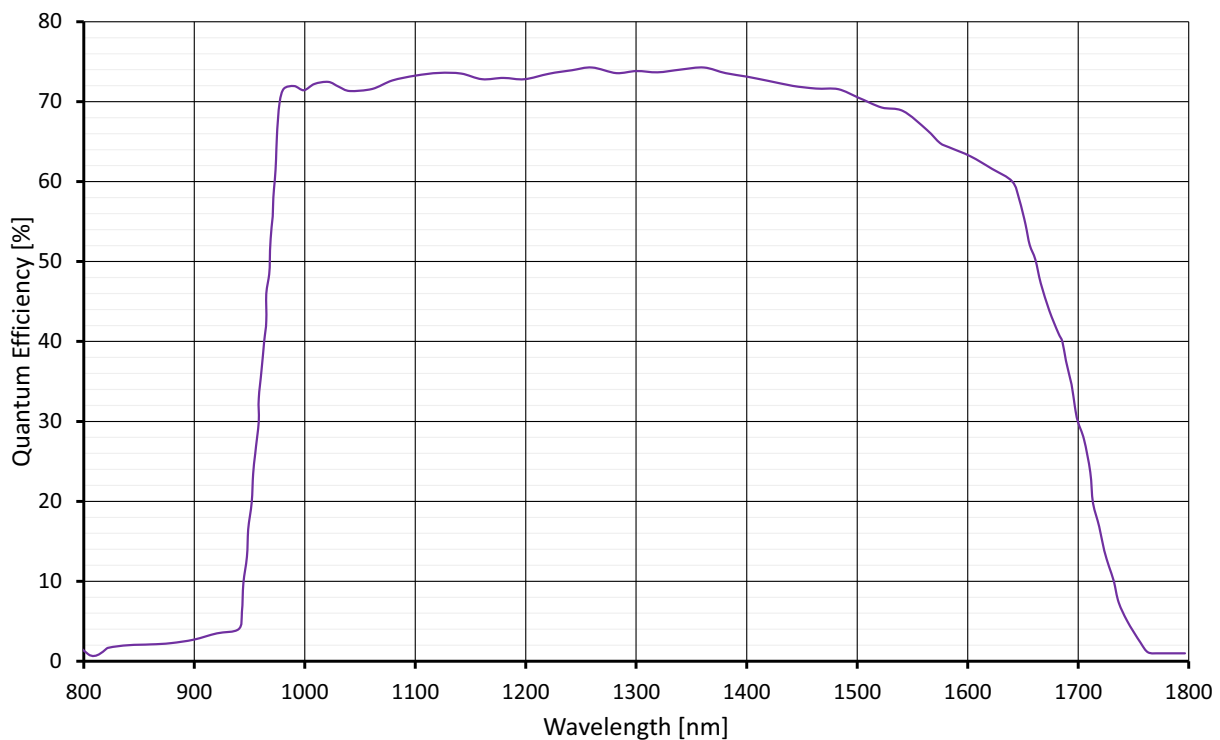

Figure 8: Goldeye G-032 TEC1 absolute QE

## Resolution and ROI frame rates

The maximum frame rate for Goldeye G-032 TEC1 is determined by the ROI size. Calculate the maximum frame rate using the following formula.

$$\text{FrameRate} = \frac{10,000,000}{\left[ (V + 4) \times \left( \frac{H}{4} + 32 \right) \right] + 131}$$

H	ROI: horizontal resolution (width). The formula is valid if $H \geq 128$ . For H always use the value rounded up to the next multiple of 16.
V	ROI: vertical resolution (height). The formula is valid if $V \geq 8$ . For V always use the value rounded up to the next multiple of 4.

When using the formula, please consider the following:

- Round the denominator down to the next full  $\mu\text{s}$ .
- Minimum ROI width is 8 pixels, minimum ROI height is 4 pixels.
- The formula generally outputs very exact values, however when the ROI approaches its minimum size, the accuracy decreases by some degree.
- Computational limitations of the host and image capture software may prevent the camera from achieving maximum frame rates.

*Formula 6: Maximum frame rate for Goldeye G-032 TEC1*

Examples for maximum frame rates with Goldeye G-032 TEC1 for common resolutions are listed in the following table.

Resolution		Format name	Maximum frame rate [fps]
Width	Height		
636	508	Sensor full resolution	100
636	480	Approx. matches VGA format	107
320	240	QVGA	351
160	120	QQVGA	1047
$\leq 128$	$\leq 8$	For all resolutions smaller than this, the frame rate remains the same.	11123

*Table 53: Goldeye G-032 TEC1 resolution and frame rates*

## Goldeye G-032 Cool TEC2

### Imaging and performance

Parameter	Values
Sensor	InGaAs, progressive scan, electronic full frame shutter
Sensor type	FPA
Spectral range	900 nm to 1700 nm
Resolution (H × V)	636 × 508
Pixel size	25 μm × 25 μm
Sensor size (effective)	15.9 mm × 12.7 mm
Dark current (at -20 °C FPA temperature)	30 ke <sup>-</sup> /s
Temporal dark noise (Gain0)	400 e <sup>-</sup>
Temporal dark noise (Gain1)	170 e <sup>-</sup>
Saturation capacity (Gain0)	1.9 Me <sup>-</sup>
Saturation capacity (Gain1)	39 ke <sup>-</sup>
Dynamic range (Gain0)	73 dB
Dynamic range (Gain1)	47 dB
Pixel operability	>99.5%
Exposure time	6 μs to 1250 ms <sup>1</sup>
Maximum frame rate at full resolution	100 fps
Temperature control	Dual-stage thermo-electric cooling (TEC2)
Analog gain factor	1 (Gain0), 50 (Gain1)
A/D converter	14-bit
Image buffer size	256 MB
Stream hold capacity	397 frames at full resolution
<sup>1</sup> Maximum exposure value given is valid for Gain0 and sensor temperature of -20 °C. Even longer exposures can be set, but the image quality may deteriorate.	

Table 54: Goldeye G-032 Cool TEC2 imaging and performance

## Output

Parameter	Values
Digital interface	GigE Vision (based on IEEE 802.3 1000BASE-T)
Bit depth	8-bit to 14-bit
Pixel formats	Mono8, Mono12, Mono12Packed, Mono14

*Table 55: Goldeye G-032 Cool TEC2 output*

## GPIOs

Parameter	Values
Opto-isolated I/Os	1 input, 2 outputs
RS232	up to 115,200 bits per second, 8N1 (adjustable)
LVTTL I/Os	1 input, 1 output

*Table 56: Goldeye G-032 Cool TEC2 GPIOs*

## Mechanics

Parameter	Values
Body dimensions (L × W × H) without lens adapter	90 mm × 80 mm × 80 mm
Lens mounts	C-Mount, F-Mount, M42-Mount
Mass, body only, without adapter	790 g
Mass, with C-Mount adapter	810 g
Mass, with F-Mount adapter	860 g
Mass, with M42-Mount adapter	830 g

*Table 57: Goldeye G-032 Cool TEC2 mechanics*

## Operating conditions

Parameter	Values
Operating temperature	-20 °C to +55 °C (housing)
Storage temperature	-30 °C to +70 °C (ambient)
Sensor cooling temperature, setpoints	<ul style="list-style-type: none"> <li>-20 °C (default and calibrated)</li> <li>-5 °C, +10 °C (uncalibrated)</li> <li>User-configurable</li> </ul>
Relative humidity	10% to 95%, non-condensing
Power requirements (DC)	<ul style="list-style-type: none"> <li>10.8 V to 30.0 V</li> <li>PoE+ (IEEE 802.3at Type 2 Class 4)</li> </ul>
Maximum power consumption	<ul style="list-style-type: none"> <li>19 W (12 VDC)</li> <li>22 W (PoE+)</li> </ul>
Typical power consumption without cooling	<ul style="list-style-type: none"> <li>6 W (12 VDC)</li> <li>8 W (PoE+)</li> </ul>

Table 58: Goldeye G-032 Cool TEC2 operating conditions

## Absolute QE

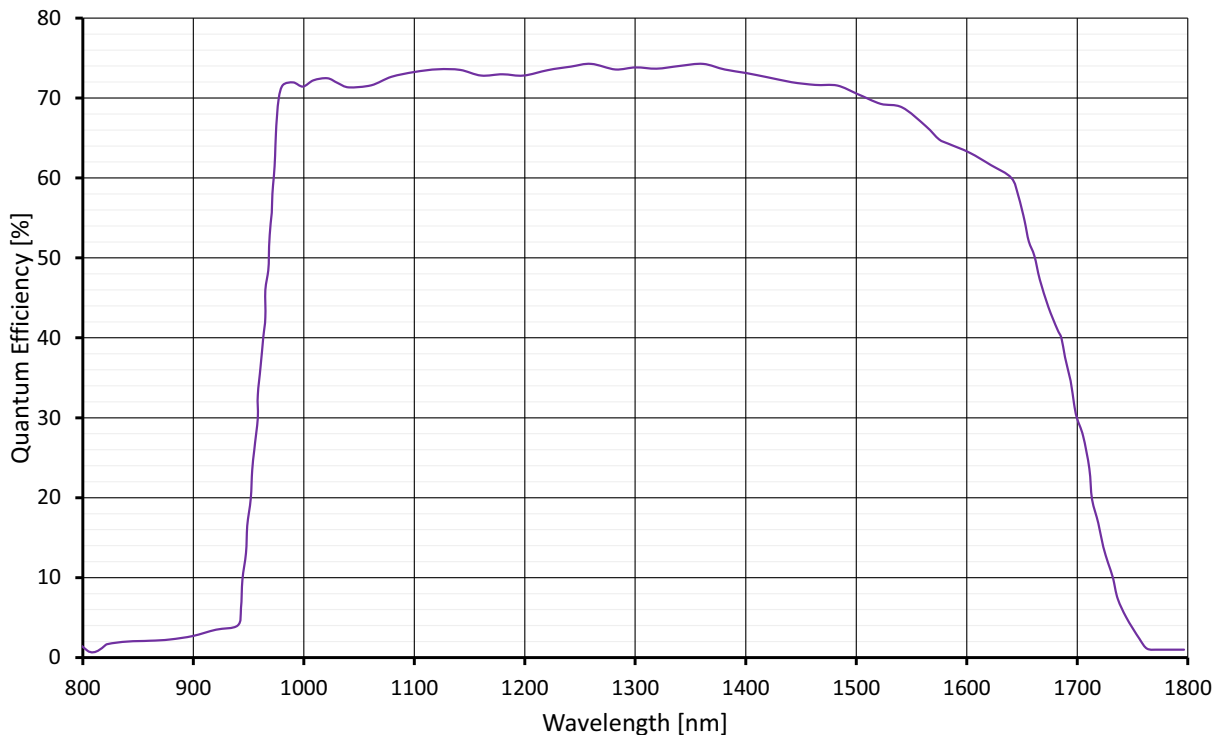

Figure 9: Goldeye G-032 Cool TEC2 absolute QE

## Resolution and ROI frame rates

The maximum frame rate for Goldeye G-032 Cool TEC2 is determined by the ROI size. Calculate the maximum frame rate using the following formula.

$$\text{FrameRate} = \frac{10,000,000}{\left[ (V + 4) \times \left( \frac{H}{4} + 32 \right) \right] + 131}$$

H	ROI: horizontal resolution (width). The formula is valid if $H \geq 128$ . For H always use the value rounded up to the next multiple of 16.
V	ROI: vertical resolution (height). The formula is valid if $V \geq 8$ . For V always use the value rounded up to the next multiple of 4.

When using the formula, please consider the following:

- Round the denominator down to the next full  $\mu\text{s}$ .
- Minimum ROI width is 8 pixels, minimum ROI height is 4 pixels.
- The formula generally outputs very exact values, however when the ROI approaches its minimum size, the accuracy decreases by some degree.
- Computational limitations of the host and image capture software may prevent the camera from achieving maximum frame rates.

*Formula 7: Maximum frame rate for Goldeye G-032 Cool TEC2*

Examples for maximum frame rates with Goldeye G-032 Cool TEC2 for common resolutions are listed in the following table.

Resolution		Format name	Maximum frame rate [fps]
Width	Height		
636	508	Sensor full resolution	100
636	480	Approx. matches VGA format	107
320	240	QVGA	351
160	120	QQVGA	1047
$\leq 128$	$\leq 8$	For all resolutions smaller than this, the frame rate remains the same.	11123

*Table 59: Goldeye G-032 Cool TEC2 resolution and frame rates*



## Goldeye G-033 TEC1

### Imaging and performance

Parameter	Values
Sensor	InGaAs, progressive scan, electronic full frame shutter
Sensor type	FPA
Spectral range	900 nm to 1700 nm
Resolution (H × V)	640 × 512
Pixel size	15 μm × 15 μm
Sensor size (effective)	9.6 mm × 7.68 mm
Dark current	110 ke <sup>-</sup> /s <sup>1</sup>
Temporal dark noise (Gain0)	390 e <sup>-</sup> <sup>1, 2</sup>
Temporal dark noise (Gain1)	53 e <sup>-</sup> <sup>1, 2</sup>
Temporal dark noise (Gain2)	32 e <sup>-</sup> <sup>1, 2</sup>
Saturation capacity (Gain0)	1.2 Me <sup>-</sup> <sup>1, 2</sup>
Saturation capacity (Gain1)	84.8 ke <sup>-</sup> <sup>1, 2</sup>
Saturation capacity (Gain2)	25 ke <sup>-</sup> <sup>1, 2</sup>
Dynamic range (Gain0)	69 dB <sup>1, 2</sup>
Dynamic range (Gain1)	64 dB <sup>1, 2</sup>
Dynamic range (Gain2)	59 dB <sup>1, 2</sup>
Pixel operability	>99.5% <sup>1, 2</sup>
Maximum frame rate at full resolution	301 fps (8-bit pixel format)
Exposure time	1 μs to 200 ms <sup>3</sup>
Temperature control	Single-stage thermo-electric cooling (TEC1)
Analog gain factor	1 (Gain0), 14 (Gain1), 45 (Gain2)
A/D converter	14-bit
Image buffer size	256 MB
Stream hold capacity	392 frames at full resolution
<sup>1</sup> Typical values that are determined similar to EMVA 1288 under 1200 nm LED illumination. Given values are mean values of multiple different measurements at 20 °C FPA temperature, if not stated otherwise.	
<sup>2</sup> Measured with CDS delay of 12 μs.	
<sup>3</sup> Maximum exposure value given is valid for Gain0 and sensor temperature of +20 °C. Even longer exposures can be set, but the image quality may deteriorate.	

Table 60: Goldeye G-033 TEC1 imaging and performance

## Output

Parameter	Values
Digital interface	GigE Vision (based on IEEE 802.3 1000BASE-T)
Bit depth	8-bit to 14-bit
Pixel formats	Mono8, Mono12, Mono12Packed, Mono14

*Table 61: Goldeye G-033 TEC1 output*

## GPIOs

Parameter	Values
Opto-isolated I/Os	1 input, 2 outputs
RS232	up to 115,200 bits per second, 8N1 (adjustable)
LVTTL I/Os	1 input, 1 output

*Table 62: Goldeye G-033 TEC1 GPIOs*

## Mechanics

Parameter	Values
Body dimensions (L × W × H) without lens adapter	78 mm × 55 mm × 55 mm
Lens mounts	C-Mount, F-Mount, M42-Mount
Mass, body only, without adapter	350 g
Mass, with C-Mount adapter	370 g
Mass, with F-Mount adapter	430 g
Mass, with M42-Mount adapter	390 g

*Table 63: Goldeye G-033 TEC1 mechanics*

## Operating conditions

Parameter	Values
Operating temperature	-20 °C to +55 °C (housing)
Storage temperature	-30 °C to +70 °C (ambient)
Sensor cooling temperature, setpoints	<ul style="list-style-type: none"> <li>• +20 °C (default and calibrated)</li> <li>• +5 °C, +35 °C, +50 °C (uncalibrated)</li> <li>• User-configurable</li> </ul>
Relative humidity	10% to 95%, non-condensing
Power requirements (DC)	<ul style="list-style-type: none"> <li>• 10.8 V to 30.0 V</li> <li>• PoE (IEEE 802.3at Type 1 Class 0)</li> </ul>
Maximum power consumption	<ul style="list-style-type: none"> <li>• 10.8 W (12 VDC)</li> <li>• &lt;12.95 W (PoE)</li> </ul>
Typical power consumption without cooling	<ul style="list-style-type: none"> <li>• 6.3W (12 VDC)</li> <li>• 8 W (PoE)</li> </ul>

Table 64: Goldeye G-033 TEC1 operating conditions

## Absolute QE

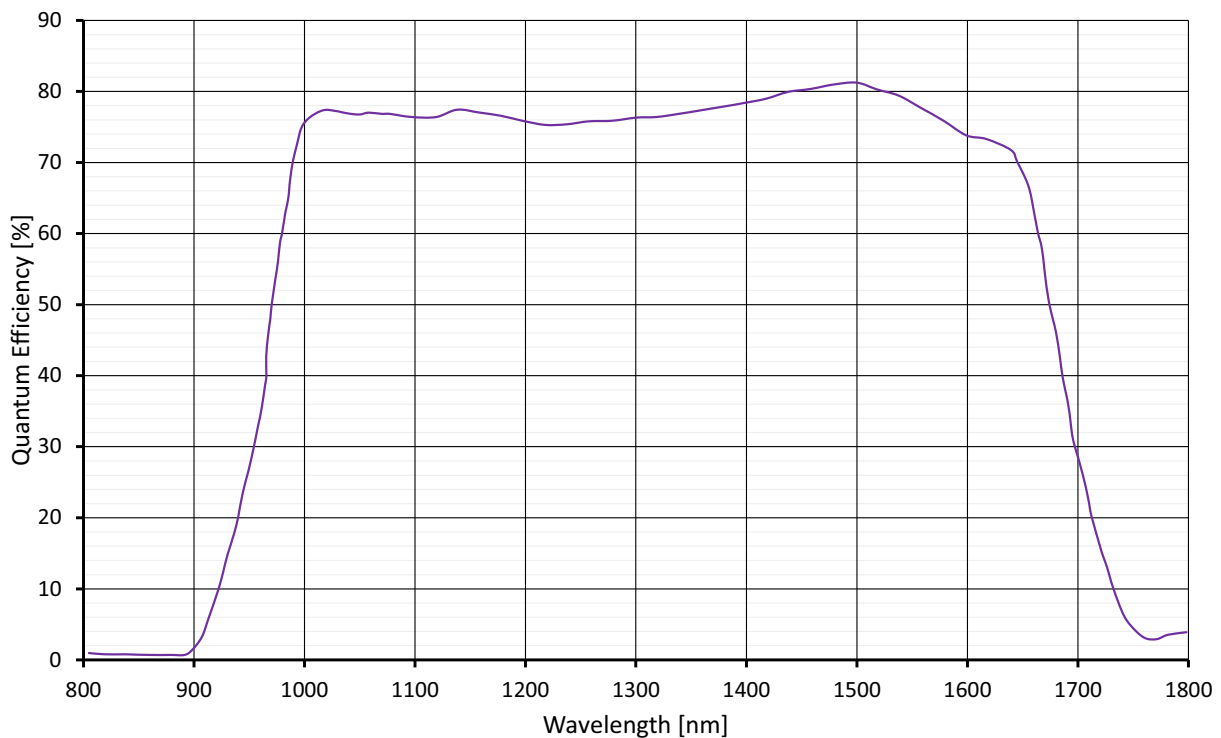

Figure 10: Goldeye G-033 TEC1 absolute QE

## Resolution and ROI frame rate

The maximum frame rate for Goldeye G-033 TEC1 is determined by the ROI size. Calculate the maximum frame rate using the following formula.

$$\text{FrameRate} = \frac{18,000,000}{\left[ (V + 1) \times \left( \frac{H}{8} + 36 \right) \right] + 254}$$

H	ROI: horizontal resolution (width). The formula is valid if $H \geq 32$ . For H always use the value rounded up to the next multiple of multiple of 32.
V	ROI: vertical resolution (height). The formula is valid if $V \geq 4$ . For V always use the value rounded up to the next multiple of 4.

When using the formula, please consider the following:

- Round the denominator up or down to the next full  $\mu\text{s}$ .
- Minimum ROI width is 8 pixels, minimum ROI height is 4 pixels.
- The formula generally outputs very exact values, however when the ROI approaches its minimum size, the accuracy decreases by some degree.
- Computational limitations of the host and image capture software may prevent the camera from achieving maximum frame rates.

*Formula 8: Maximum frame rate for Goldeye G-033 TEC1*

Examples for maximum frame rates with Goldeye G-033 TEC1 for common resolutions are listed in the following table.

Resolution		Format name	Maximum frame rate [fps] (Pixel format)	
Width	Height			
640	512	Sensor full resolution	301	(8-bit)
640	480	VGA	321	(8-bit)
320	240	QVGA	968	(8-bit)
160	120	QQVGA	2557	(8-bit or 12-bit)
$\leq 128$	$\leq 24$	For all resolutions smaller than this, the frame rate remains the same.	>11627	(8-bit)

*Table 65: Goldeye G-033 TEC1 resolution and frame rates*

## Goldeye G-033 TECless

### Imaging and performance

Parameter	Values
Sensor	InGaAs, progressive scan, electronic full frame shutter
Sensor type	FPA
Spectral range	900 nm to 1700 nm
Resolution (H × V)	640 × 512
Pixel size	15 μm × 15 μm
Sensor size (effective)	9.6 mm × 7.68 mm
Dark current (at +45 °C FPA temperature)	430 ke <sup>-</sup> /s <sup>1</sup>
Temporal dark noise (Gain0)	390 e <sup>-</sup> <sup>1, 2</sup>
Temporal dark noise (Gain1)	53 e <sup>-</sup> <sup>1, 2</sup>
Temporal dark noise (Gain2)	32 e <sup>-</sup> <sup>1, 2</sup>
Saturation capacity (Gain0)	1.2 Me <sup>-</sup> <sup>1, 2</sup>
Saturation capacity (Gain1)	84.8 ke <sup>-</sup> <sup>1, 2</sup>
Saturation capacity (Gain2)	25 ke <sup>-</sup> <sup>1, 2</sup>
Dynamic range (Gain0)	69 dB <sup>1, 2</sup>
Dynamic range (Gain1)	64 dB <sup>1, 2</sup>
Dynamic range (Gain2)	59 dB <sup>1, 2</sup>
Pixel operability	>99.5%
Maximum frame rate at full resolution	301 fps (in 8-bit pixel format)
Exposure time	1 μs to 200 ms <sup>3</sup>
Temperature control	Without thermo-electric cooling (TECless)
Analog gain factor	1 (Gain0), 14 (Gain1), 45 (Gain2)
A/D converter	14-bit
Image buffer size	256 MB
Stream hold capacity	392 frames at full resolution

<sup>1</sup> Typical values that are determined similar to EMVA 1288 under 1200 nm LED illumination. Given values are mean values of multiple different measurements at +45 °C FPA temperature, if not stated otherwise.

<sup>2</sup> Measured with CDS delay of 12 μs.

<sup>3</sup> Maximum exposure value given is valid for Gain0 and sensor temperature of +45 °C. Even longer exposures can be set, but the image quality may deteriorate.

Table 66: Goldeye G-033 TECless imaging and performance

## Output

Parameter	Values
Digital interface	GigE Vision (based on IEEE 802.3 1000BASE-T)
Bit depth	8-bit to 14-bit
Pixel formats	Mono8, Mono12, Mono12Packed, Mono14

*Table 67: Goldeye G-033 TECless output*

## GPIOs

Parameter	Values
Opto-isolated I/Os	1 input, 2 outputs
RS232	up to 115,200 bits per second, 8N1 (adjustable)
LVTTL I/Os	1 input, 1 output

*Table 68: Goldeye G-033 TECless GPIOs*

## Mechanics

Parameter	Values
Body dimensions (L × W × H) without lens adapter	78 mm × 55 mm × 55 mm
Lens mounts	<ul style="list-style-type: none"> <li>• C-Mount</li> <li>• F-Mount and M42-Mount available on request</li> </ul>
Mass, body only, without adapter	330 g
Mass, with C-Mount adapter	350 g
Mass, with F-Mount adapter	400 g
Mass, with M42-Mount adapter	370 g

*Table 69: Goldeye G-033 TECless mechanics*

## Operating conditions

Parameter	Values
Operating temperature	-20 °C to +55 °C (housing)
Storage temperature	-30 °C to +70 °C (ambient)
Sensor cooling temperature, setpoints	Not applicable to TECless models.
Relative humidity	10% to 95%, non-condensing
Power requirements (DC)	<ul style="list-style-type: none"> <li>• 10.8 V to 30.0 V</li> <li>• PoE (IEEE 802.3at Type 1 Class 0)</li> </ul>
Maximum power consumption	<ul style="list-style-type: none"> <li>• 6.0 W (12 VDC)</li> <li>• &lt;7.5 W (PoE)</li> </ul>
Typical power consumption without cooling	<ul style="list-style-type: none"> <li>• 6.0 W (12 VDC)</li> <li>• 6.0 W (PoE)</li> </ul>

Table 70: Goldeye G-033 TECless operating conditions

## Absolute QE

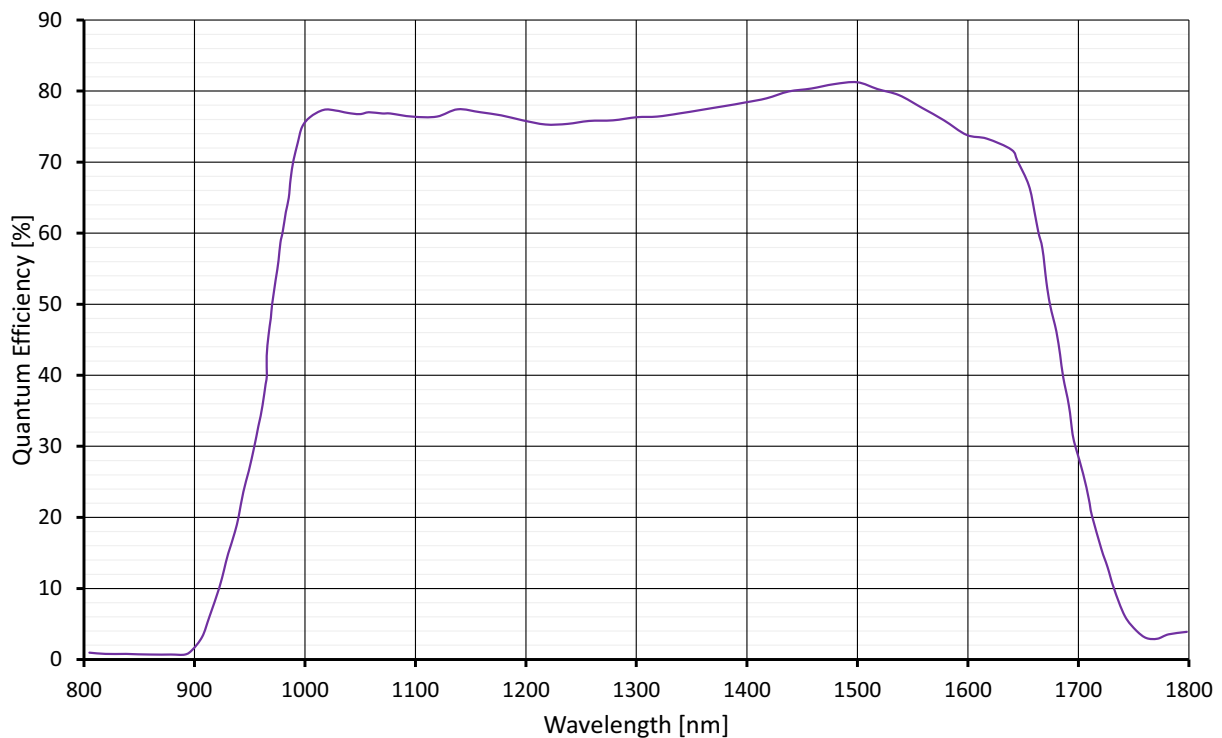

Figure 11: Goldeye G-033 TECless absolute QE

## Resolution and ROI frame rate

The maximum frame rate for Goldeye G-033 TECless is determined by the ROI size. Calculate the maximum frame rate using the following formula.

$$\text{FrameRate} = \frac{18,000,000}{\left[ (V + 1) \times \left( \frac{H}{8} + 36 \right) \right] + 254}$$

H	ROI: horizontal resolution (width). The formula is valid if $H \geq 32$ . For H always use the value rounded up to the next multiple of 32.
V	ROI: vertical resolution (height). The formula is valid if $V \geq 4$ . For V always use the value rounded up to the next multiple of 4.

When using the formula, please consider the following:

- Round the denominator up or down to the next full  $\mu\text{s}$ .
- Minimum ROI width is 8 pixels, minimum ROI height is 4 pixels.
- The formula generally outputs very exact values, however when the ROI approaches its minimum size, the accuracy decreases by some degree.
- Computational limitations of the host and image capture software may prevent the camera from achieving maximum frame rates.

*Formula 9: Maximum frame rate for Goldeye G-033 TECless*

Examples for maximum frame rates with Goldeye G-033 TECless for common resolutions are listed in the following table.

Resolution		Format name	Maximum frame rate [fps]	
Width	Height		(Pixel format)	
640	512	Sensor full resolution	301	(8-bit)
640	480	VGA	321	(8-bit)
320	240	QVGA	968	(8-bit)
160	120	QQVGA	2557	(8-bit or 12-bit)
$\leq 128$	$\leq 24$	For all resolutions smaller than this, the frame rate remains the same.	>11627	(8-bit)

*Table 71: Goldeye G-033 TECless resolution and frame rates*



## Goldeye G-034 TEC1

### Imaging and performance

Parameter	Values
Sensor	InGaAs, progressive scan, electronic full frame shutter
Sensor type	FPA
Spectral range	900 nm to 1700 nm
Resolution (H × V)	636 × 508
Pixel size	15 μm × 15 μm
Sensor size (effective)	9.54 mm × 7.62 mm
Dark current	49 ke <sup>-</sup> /s <sup>1</sup>
Temporal dark noise (Gain0)	390 e <sup>-</sup> <sup>1, 2</sup>
Temporal dark noise (Gain1)	53 e <sup>-</sup> <sup>1, 2</sup>
Temporal dark noise (Gain2)	32 e <sup>-</sup> <sup>1, 2</sup>
Saturation capacity (Gain0)	1.2 Me <sup>-</sup> <sup>1, 2</sup>
Saturation capacity (Gain1)	84.8 ke <sup>-</sup> <sup>1, 2</sup>
Saturation capacity (Gain2)	25 ke <sup>-</sup> <sup>1, 2</sup>
Dynamic range (Gain0)	69 dB <sup>1, 2</sup>
Dynamic range (Gain1)	64 dB <sup>1, 2</sup>
Dynamic range (Gain2)	59 dB <sup>1, 2</sup>
Pixel operability	>99.5% <sup>1, 2</sup>
Maximum frame rate at full resolution	303 fps (8-bit pixel format)
Exposure time	1 μs to 200 ms <sup>3</sup>
Temperature control	Single-stage thermo-electric cooling (TEC1)
Analog gain factor	1 (Gain0), 14 (Gain1), 45 (Gain2)
A/D converter	14-bit
Image buffer size	256 MB
Stream hold capacity	392 frames at full resolution

<sup>1</sup> Typical values that are determined similar to EMVA 1288 under 1200 nm LED illumination. Given values are mean values of multiple different measurements at 20 °C FPA temperature, if not stated otherwise.

<sup>2</sup> Measured with CDS delay of 12 μs.

<sup>3</sup> Maximum exposure value given is valid for Gain0 and sensor temperature of +20 °C. Even longer exposures can be set, but the image quality may deteriorate.

Table 72: Goldeye G-034 TEC1 imaging and performance

## Output

Parameter	Values
Digital interface	GigE Vision (based on IEEE 802.3 1000BASE-T)
Bit depth	8-bit to 16-bit
Pixel formats	Mono8, Mono10, Mono10p, Mono10Packed, Mono12, Mono12p, Mono12Packed, Mono14, Mono16

Table 73: Goldeye G-034 TEC1 output

## GPIOs

Parameter	Values
Opto-isolated I/Os	1 input, 2 outputs
RS232	up to 115,200 bits per second, 8N1 (adjustable)
LVTTL I/Os	1 input, 1 output

Table 74: Goldeye G-034 TEC1 GPIOs

## Mechanics

Parameter	Values
Body dimensions (L × W × H) without lens adapter	78 mm × 55 mm × 55 mm
Lens mounts	C-Mount, F-Mount, M42-Mount
Mass, body only, without adapter	350 g
Mass, with C-Mount adapter	370 g
Mass, with F-Mount adapter	430 g
Mass, with M42-Mount adapter	390 g

Table 75: Goldeye G-034 TEC1 mechanics

## Operating conditions

Parameter	Values
Operating temperature	-20 °C to +55 °C (housing)
Storage temperature	-30 °C to +70 °C (ambient)
Sensor cooling temperature, setpoints	<ul style="list-style-type: none"> <li>• +20 °C (default and calibrated)</li> <li>• +5 °C, +35 °C, +50 °C (uncalibrated)</li> <li>• User-configurable</li> </ul>
Relative humidity	10% to 95%, non-condensing
Power requirements (DC)	<ul style="list-style-type: none"> <li>• 10.8 V to 30.0 V</li> <li>• PoE (IEEE 802.3at Type 1 Class 0)</li> </ul>
Maximum power consumption	<ul style="list-style-type: none"> <li>• 10.8 W (12 VDC)</li> <li>• &lt;12.95 W (PoE)</li> </ul>
Typical power consumption without cooling	<ul style="list-style-type: none"> <li>• 6.3 W (12 VDC)</li> <li>• 8 W (PoE)</li> </ul>

Table 76: Goldeye G-034 TEC1 operating conditions

## Absolute QE

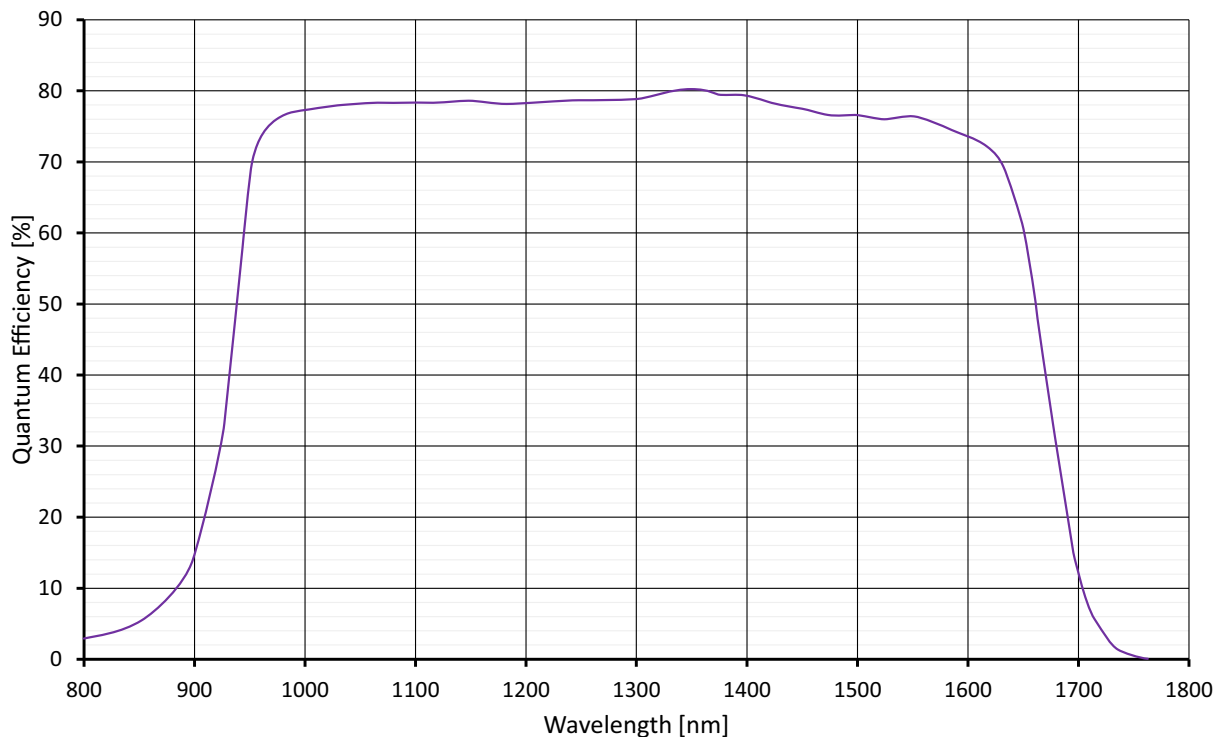

Figure 12: Goldeye G-034 TEC1 absolute QE

## Resolution and ROI frame rate

The maximum frame rate for Goldeye G-034 TEC1 is determined by the ROI size. Calculate the maximum frame rate using the following formula.

$$\text{FrameRate} = \frac{18,000,000}{\left[ (V + 1) \times \left( \frac{H}{8} + 36 \right) \right] + 254}$$

H	ROI: horizontal resolution (width). The formula is valid if $H \geq 32$ . For H always use the value rounded up to the next multiple of multiple of 32.
V	ROI: vertical resolution (height). The formula is valid if $V \geq 4$ . For V always use the value rounded up to the next multiple of 4.

When using the formula, please consider the following:

- Round the denominator up or down to the next full  $\mu\text{s}$ .
- Minimum ROI width is 8 pixels, minimum ROI height is 4 pixels.
- The formula generally outputs very exact values, however when the ROI approaches its minimum size, the accuracy decreases by some degree.
- Computational limitations of the host and image capture software may prevent the camera from achieving maximum frame rates.

*Formula 10: Maximum frame rate for Goldeye G-034 TEC1*

Examples for maximum frame rates with Goldeye G-034 TEC1 for common resolutions are listed in the following table.

Resolution		Format name	Maximum frame rate [fps] (Pixel format)	
Width	Height			
636	508	Sensor full resolution	303	(8-bit)
636	480	Approx. matches VGA format	321	(8-bit)
320	240	QVGA	968	(8-bit)
160	120	QQVGA	2557	(8-bit or 12-bit)
$\leq 128$	$\leq 24$	For all resolutions smaller than this, the frame rate remains the same.	>11627	(8-bit)

*Table 77: Goldeye G-034 TEC1 resolution and frame rates*

## Goldeye G-034 TEC2

### Imaging and performance



#### Measurement values

Actual values for dark current and temporal dark noise partly depend on the ambient temperature of your application.

Parameter	Values
Sensor	InGaAs, progressive scan, electronic full frame shutter
Sensor type	FPA
Spectral range	900 nm to 1700 nm
Resolution (H × V)	636 × 508
Pixel size	15 μm × 15 μm
Sensor size (effective)	9.54 mm × 7.62 mm
Dark current	26 ke <sup>-</sup> /s <sup>1</sup>
Temporal dark noise (Gain0)	390 e <sup>-</sup> <sup>1, 2</sup>
Temporal dark noise (Gain1)	53 e <sup>-</sup> <sup>1, 2</sup>
Temporal dark noise (Gain2)	32 e <sup>-</sup> <sup>1, 2</sup>
Saturation capacity (Gain0)	1.2 Me <sup>-</sup> <sup>1, 2</sup>
Saturation capacity (Gain1)	84.8 ke <sup>-</sup> <sup>1, 2</sup>
Saturation capacity (Gain2)	25 ke <sup>-</sup> <sup>1, 2</sup>
Dynamic range (Gain0)	69 dB <sup>1, 2</sup>
Dynamic range (Gain1)	64 dB <sup>1, 2</sup>
Dynamic range (Gain2)	59 dB <sup>1, 2</sup>
Pixel operability	>99.5% <sup>1, 2</sup>
Maximum frame rate at full resolution	303 fps (8-bit pixel format)
Exposure time	1 μs to 10 s <sup>3</sup>
Temperature control	Dual-stage thermo-electric cooling (TEC2)
Analog gain factor	1 (Gain0), 14 (Gain1), 45 (Gain2)
<sup>1</sup> Typical values that are determined similar to EMVA 1288 under 1200 nm LED illumination. Given values are mean values of multiple different measurements at -30 °C FPA temperature, if not stated otherwise.	
<sup>2</sup> Measured with CDS delay of 12 μs.	
<sup>3</sup> Maximum exposure value given is valid for Gain0 and sensor temperature of -30 °C. Even longer exposures can be set, but the image quality may deteriorate.	

Table 78: Goldeye G-034 TEC2 imaging and performance (sheet 1 of 2)

Parameter	Values
A/D converter	14-bit
Image buffer size	256 MB
Stream hold capacity	392 frames at full resolution
<sup>1</sup> Typical values that are determined similar to EMVA 1288 under 1200 nm LED illumination. Given values are mean values of multiple different measurements at -30 °C FPA temperature, if not stated otherwise. <sup>2</sup> Measured with CDS delay of 12 μs. <sup>3</sup> Maximum exposure value given is valid for Gain0 and sensor temperature of -30 °C. Even longer exposures can be set, but the image quality may deteriorate.	

Table 78: Goldeye G-034 TEC2 imaging and performance (sheet 2 of 2)

## Output

Parameter	Values
Digital interface	GigE Vision (based on IEEE 802.3 1000BASE-T)
Bit depth	8-bit to 16-bit
Pixel formats	Mono8, Mono10, Mono10p, Mono10Packed, Mono12, Mono12p, Mono12Packed, Mono14, Mono16

Table 79: Goldeye G-034 TEC2 output

## GPIOs

Parameter	Values
Opto-isolated I/Os	1 input, 2 outputs
RS232	up to 115,200 bits per second, 8N1 (adjustable)
LVTTL I/Os	1 input, 1 output

Table 80: Goldeye G-034 TEC2 GPIOs

## Mechanics

Parameter	Values
Body dimensions (L × W × H) without lens adapter	90 mm × 80 mm × 80 mm
Lens mount	C-Mount
Mass, including lens mount	740 g

Table 81: Goldeye G-034 TEC2 mechanics

## Operating conditions

Parameter	Values
Operating temperature	-20 °C to +55 °C (housing)
Storage temperature	-30 °C to +70 °C (ambient)
Sensor cooling temperature, setpoints	<ul style="list-style-type: none"> <li>-30 °C (default and calibrated)</li> <li>-20 °C, -10 °C (calibrated)</li> <li>0 °C (uncalibrated)</li> <li>User-configurable</li> </ul>
Relative humidity	10% to 95%, non-condensing
Power requirements (DC)	<ul style="list-style-type: none"> <li>10.8 V to 30.0 V</li> <li>PoE+ (IEEE 802.3at Type 2 Class 4)</li> </ul>
Maximum power consumption	<ul style="list-style-type: none"> <li>21 W (12 VDC)</li> <li>&lt;23 W (PoE)</li> </ul>
Typical power consumption without cooling	<ul style="list-style-type: none"> <li>7 W (12 VDC)</li> <li>9 W (PoE)</li> </ul>

Table 82: Goldeye G-034 TEC2 operating conditions

## Absolute QE

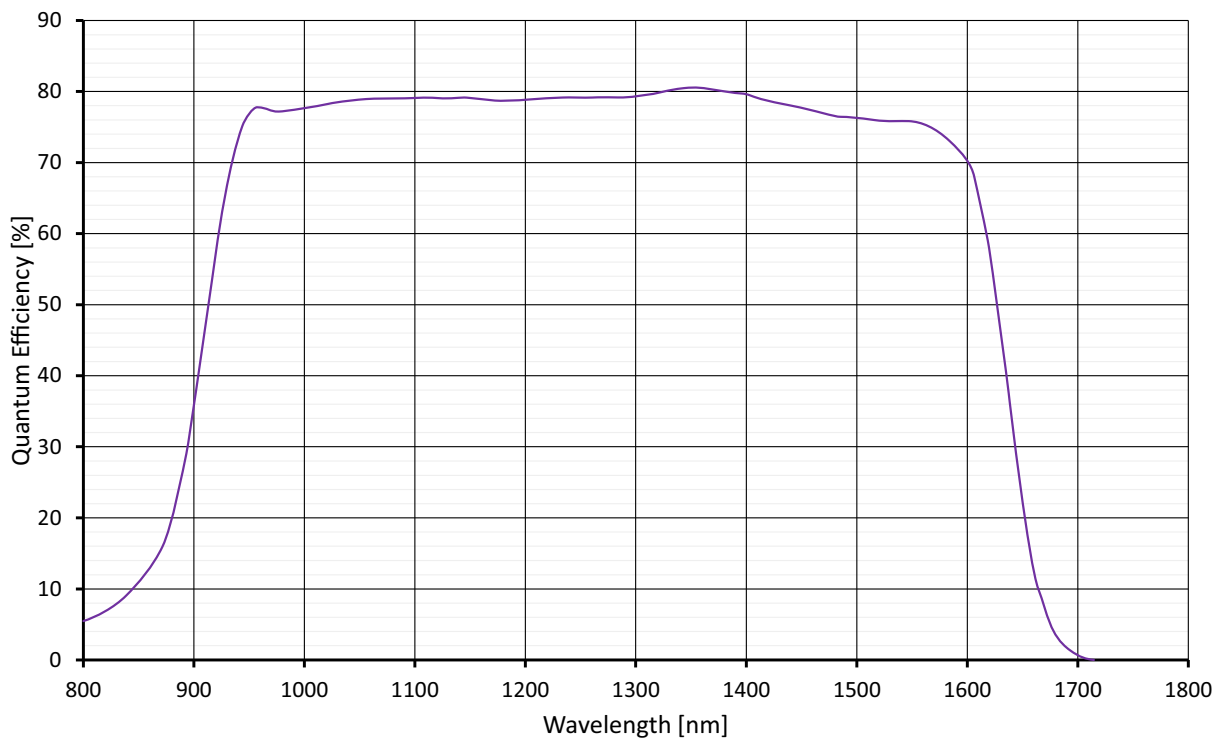

Figure 13: Goldeye G-034 TEC2 absolute QE

## Resolution and ROI frame rate

The maximum frame rate for Goldeye G-034 TEC2 is determined by the ROI size. Calculate the maximum frame rate using the following formula.

$$\text{FrameRate} = \frac{18,000,000}{\left[ (V + 1) \times \left( \frac{H}{8} + 36 \right) \right] + 254}$$

H	ROI: horizontal resolution (width). The formula is valid if $H \geq 32$ . For H always use the value rounded up to the next multiple of multiple of 32.
V	ROI: vertical resolution (height). The formula is valid if $V \geq 4$ . For V always use the value rounded up to the next multiple of 4.

When using the formula, please consider the following:

- Round the denominator up or down to the next full  $\mu\text{s}$ .
- Minimum ROI width is 8 pixels, minimum ROI height is 4 pixels.
- The formula generally outputs very exact values, however when the ROI approaches its minimum size, the accuracy decreases by some degree.
- Computational limitations of the host and image capture software may prevent the camera from achieving maximum frame rates.

*Formula 11: Maximum frame rate for Goldeye G-034 TEC2*

Examples for maximum frame rates with Goldeye G-034 TEC2 for common resolutions are listed in the following table.

Resolution		Format name	Maximum frame rate [fps] (Pixel format)	
Width	Height			
636	508	Sensor full resolution	303	(8-bit)
636	480	Approx. matches VGA format	321	(8-bit)
320	240	QVGA	968	(8-bit)
160	120	QQVGA	2557	(8-bit or 12-bit)
$\leq 128$	$\leq 24$	For all resolutions smaller than this, the frame rate remains the same.	>11627	(8-bit)

*Table 83: Goldeye G-034 TEC2 resolution and frame rates*



## Goldeye G-034 XSWIR 1.9 TEC2

### Imaging and performance

Parameter	Values
Sensor	InGaAs, progressive scan, electronic full frame shutter
Sensor type	FPA
Spectral range	1100 nm to 1900 nm
Resolution (H × V)	636 × 508
Pixel size	15 μm × 15 μm
Sensor size (effective)	9.54 mm × 7.62 mm
Dark current	140 ke <sup>-</sup> /s <sup>1</sup>
Temporal dark noise (Gain0)	434 e <sup>-</sup> <sup>1, 2</sup>
Temporal dark noise (Gain1)	40 e <sup>-</sup> <sup>1, 2</sup>
Temporal dark noise (Gain2)	15 e <sup>-</sup> <sup>1, 2</sup>
Saturation capacity (Gain0)	1.3 Me <sup>-</sup> <sup>1, 2</sup>
Saturation capacity (Gain1)	66 ke <sup>-</sup> <sup>1, 2</sup>
Saturation capacity (Gain2)	18 ke <sup>-</sup> <sup>1, 2</sup>
Dynamic range (Gain0)	69 dB <sup>1, 2</sup>
Dynamic range (Gain1)	64 dB <sup>1, 2</sup>
Dynamic range (Gain2)	61 dB <sup>1, 2</sup>
Pixel operability	>98.5% <sup>1, 2</sup>
Maximum frame rate at full resolution	303 fps (8-bit pixel format)
Exposure time	1 μs to 20 ms <sup>3</sup>
Temperature control	Dual-stage thermo-electric cooling (TEC2)
Analog gain factor	1 (Gain0), 14 (Gain1), 45 (Gain2)
A/D converter	14-bit
Image buffer size	256 MB
Stream hold capacity	392 frames at full resolution
<sup>1</sup> Typical values that are determined similar to EMVA 1288 under 1200 nm LED illumination. Given values are mean values of multiple different measurements at -30 °C FPA temperature, if not stated otherwise.	
<sup>2</sup> Measured with CDS delay of 12 μs.	
<sup>3</sup> Maximum exposure value given is valid for Gain0 and sensor temperature of -30 °C. Even longer exposures can be set, but the image quality may deteriorate.	

Table 84: Goldeye G-034 XSWIR 1.9 TEC2 imaging and performance

## Output

Parameter	Values
Digital interface	GigE Vision (based on IEEE 802.3 1000BASE-T)
Bit depth	8-bit to 16-bit
Pixel formats	Mono8, Mono10, Mono10p, Mono10Packed, Mono12, Mono12p, Mono12Packed, Mono14, Mono16

*Table 85: Goldeye G-034 XSWIR 1.9 TEC2 output*

## GPIOs

Parameter	Values
Opto-isolated I/Os	1 input, 2 outputs
RS232	up to 115,200 bits per second, 8N1 (adjustable)
LVTTL I/Os	1 input, 1 output

*Table 86: Goldeye G-034 XSWIR 1.9 TEC2 GPIOs*

## Mechanics

Parameter	Values
Body dimensions (L × W × H) without lens mount adapter	90 mm × 80 mm × 80 mm
Lens mount	C-Mount
Mass, including lens mount	740 g

*Table 87: Goldeye G-034 XSWIR 1.9 TEC2 mechanics*

## Operating conditions

Parameter	Values
Operating temperature	-20 °C to +55 °C (housing)
Storage temperature	-30 °C to +70 °C (ambient)
Sensor cooling temperature, setpoints	<ul style="list-style-type: none"> <li>• -30 °C (default and calibrated)</li> <li>• -20 °C, -10 °C (calibrated)</li> <li>• 0 °C (uncalibrated)</li> <li>• User-configurable</li> </ul>
Relative humidity	10% to 95%, non-condensing
Power requirements (DC)	<ul style="list-style-type: none"> <li>• 10.8 V to 30.0 V</li> <li>• PoE+ (IEEE 802.3at Type 2 Class 4)</li> </ul>
Maximum power consumption	<ul style="list-style-type: none"> <li>• 21 W (12 VDC)</li> <li>• &lt;23 W (PoE)</li> </ul>
Typical power consumption without cooling	<ul style="list-style-type: none"> <li>• 7 W (12 VDC)</li> <li>• 9 W (PoE)</li> </ul>

*Table 88: Goldeye G-034 XSWIR 1.9 TEC2 operating conditions*

## Absolute QE



### Quantum efficiency for various sensor temperature values

The following curves relate to a sensor temperatures of -20 °C and -30 °C default, the sensitivity is slightly shifted to lower wave lengths, but the range is maintained. With increased sensor temperatures, the QE curve is slightly shifted to longer wavelengths, and for lower temperatures it is shifted to shorter wavelengths.

See the corresponding application note at [www.alliedvision.com/fileadmin/content/documents/products/cameras/Goldeye\\_2/appnote/Goldeye-G-CL\\_AppNote\\_Temperature-Influence-on-Image-Quality\\_en.pdf](http://www.alliedvision.com/fileadmin/content/documents/products/cameras/Goldeye_2/appnote/Goldeye-G-CL_AppNote_Temperature-Influence-on-Image-Quality_en.pdf).

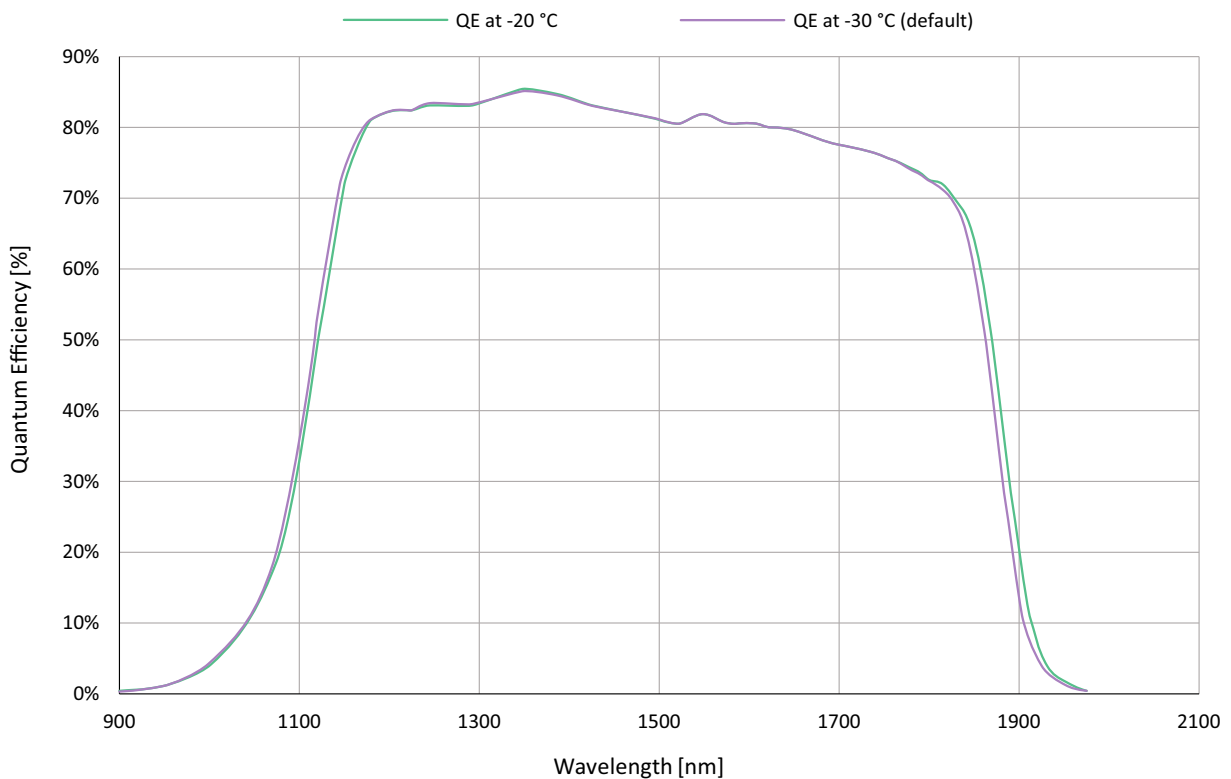

Figure 14: Goldeye G-034 XSWIR 1.9 TEC2 absolute QE

## Resolution and ROI frame rate



### Values when using MultiRegions features

When the camera is operated using more than a single ROI, values in this section may not be reached.

The maximum frame rate for Goldeye G-034 XSWIR 1.9 TEC2 is determined by the ROI size. Calculate the maximum frame rate using the following formula.

$$\text{FrameRate} = \frac{18,000,000}{\left[ (V + 1) \times \left( \frac{H}{8} + 36 \right) \right] + 254}$$

H	ROI: horizontal resolution (width). The formula is valid if $H \geq 32$ . For H always use the value rounded up to the next multiple of multiple of 32.
V	ROI: vertical resolution (height). The formula is valid if $V \geq 4$ . For V always use the value rounded up to the next multiple of 4.

When using the formula, please consider the following:

- Round the denominator up or down to the next full  $\mu$ s.
- Minimum ROI width is 8 pixels, minimum ROI height is 4 pixels.
- The formula generally outputs very exact values, however when the ROI approaches its minimum size, the accuracy decreases by some degree.
- Computational limitations of the host and image capture software may prevent the camera from achieving maximum frame rates.

*Formula 12: Maximum frame rate for Goldeye G-034 XSWIR 1.9 TEC2*

Examples for maximum frame rates with Goldeye G-034 XSWIR 1.9 TEC2 for common resolutions are listed in the following table.

Resolution		Format name	Maximum frame rate [fps] (Pixel format)	
Width	Height			
636	508	Sensor full resolution	303	(8-bit)
636	480	Approx. matches VGA format	321	(8-bit)
320	240	QVGA	968	(8-bit)
160	120	QQVGA	2557	(8-bit or 12-bit)
$\leq 128$	$\leq 24$	For all resolutions smaller than this, the frame rate remains the same.	>11627	(8-bit)

*Table 89: Goldeye G-034 XSWIR 1.9 TEC2 resolution and frame rates*

## Goldeye G-034 XSWIR 2.2 TEC2

### Imaging and performance

Parameter	Values
Sensor	InGaAs, progressive scan, electronic full frame shutter
Sensor type	FPA
Spectral range	1200 nm to 2200 nm
Resolution (H × V)	636 × 508
Pixel size	15 μm × 15 μm
Sensor size (effective)	9.54 mm × 7.62 mm
Dark current	820 ke <sup>-</sup> /s <sup>1</sup>
Temporal dark noise (Gain0)	452 e <sup>-</sup> <sup>1, 2</sup>
Temporal dark noise (Gain1)	134 e <sup>-</sup> <sup>1, 2</sup>
Temporal dark noise (Gain2)	58 e <sup>-</sup> <sup>1, 2</sup>
Saturation capacity (Gain0)	1.16 Me <sup>-</sup> <sup>1, 2</sup>
Saturation capacity (Gain1)	73 ke <sup>-</sup> <sup>1, 2</sup>
Saturation capacity (Gain2)	25 ke <sup>-</sup> <sup>1, 2</sup>
Dynamic range (Gain0)	68 dB <sup>1, 2</sup>
Dynamic range (Gain1)	54 dB <sup>1, 2</sup>
Dynamic range (Gain2)	52 dB <sup>1, 2</sup>
Pixel operability	>98.5% <sup>1, 2</sup>
Maximum frame rate at full resolution	303 fps (8-bit pixel format)
Exposure time	1 μs to 10 ms <sup>3</sup>
Temperature control	Dual-stage thermo-electric cooling (TEC2)
Analog gain factor	1 (Gain0), 14 (Gain1), 45 (Gain2)
A/D converter	14-bit
Image buffer size	256 MB
Stream hold capacity	392 frames at full resolution
<sup>1</sup> Typical values that are determined similar to EMVA 1288 under 1485 nm LED illumination. Given values are mean values of multiple different measurements at -30 °C FPA temperature, if not stated otherwise.	
<sup>2</sup> Measured with CDS delay of 12 μs.	
<sup>3</sup> Maximum exposure value given is valid for Gain0 and sensor temperature of -30 °C. Even longer exposures can be set, but the image quality may deteriorate.	

Table 90: Goldeye G-034 XSWIR 2.2 TEC2 imaging and performance

## Output

Parameter	Values
Digital interface	GigE Vision (based on IEEE 802.3 1000BASE-T)
Bit depth	8-bit to 16-bit
Pixel formats	Mono8, Mono10, Mono10p, Mono10Packed, Mono12, Mono12p, Mono12Packed, Mono14, Mono16

*Table 91: Goldeye G-034 XSWIR 2.2 TEC2 output*

## GPIOs

Parameter	Values
Opto-isolated I/Os	1 input, 2 outputs
RS232	up to 115,200 bits per second, 8N1 (adjustable)
LVTTL I/Os	1 input, 1 output

*Table 92: Goldeye G-034 XSWIR 2.2 TEC2 GPIOs*

## Mechanics

Parameter	Values
Body dimensions (L × W × H) without lens mount adapter	90 mm × 80 mm × 80 mm
Lens mount	C-Mount
Mass, including lens mount	740 g

*Table 93: Goldeye G-034 XSWIR 2.2 TEC2 mechanics*

## Operating conditions

Parameter	Values
Operating temperature	-20 °C to +55 °C (housing)
Storage temperature	-30 °C to +70 °C (ambient)
Sensor cooling temperature, setpoints	<ul style="list-style-type: none"> <li>• -30 °C (default and calibrated)</li> <li>• -20 °C, -10 °C (calibrated)</li> <li>• 0 °C (uncalibrated)</li> <li>• User-configurable</li> </ul>
Relative humidity	10% to 95%, non-condensing
Power requirements (DC)	<ul style="list-style-type: none"> <li>• 10.8 V to 30.0 V</li> <li>• PoE+ (IEEE 802.3at Type 2 Class 4)</li> </ul>
Maximum power consumption	<ul style="list-style-type: none"> <li>• 21 W (12 VDC)</li> <li>• &lt;23 W (PoE)</li> </ul>
Typical power consumption without cooling	<ul style="list-style-type: none"> <li>• 7 W (12 VDC)</li> <li>• 9 W (PoE)</li> </ul>

Table 94: Goldeye G-034 XSWIR 2.2 TEC2 operating conditions



## Absolute QE



### Quantum efficiency for various sensor temperature values

The following curves relate to a sensor temperatures of -20 °C and -30 °C default, the sensitivity is slightly shifted to lower wave lengths, but the range is maintained. With increased sensor temperatures, the QE curve is slightly shifted to longer wavelengths, and for lower temperatures it is shifted to shorter wavelengths.

See the corresponding application note at [www.alliedvision.com/fileadmin/content/documents/products/cameras/Goldeye\\_2/appnote/Goldeye-G-CL\\_AppNote\\_Temperature-Influence-on-Image-Quality\\_en.pdf](http://www.alliedvision.com/fileadmin/content/documents/products/cameras/Goldeye_2/appnote/Goldeye-G-CL_AppNote_Temperature-Influence-on-Image-Quality_en.pdf).

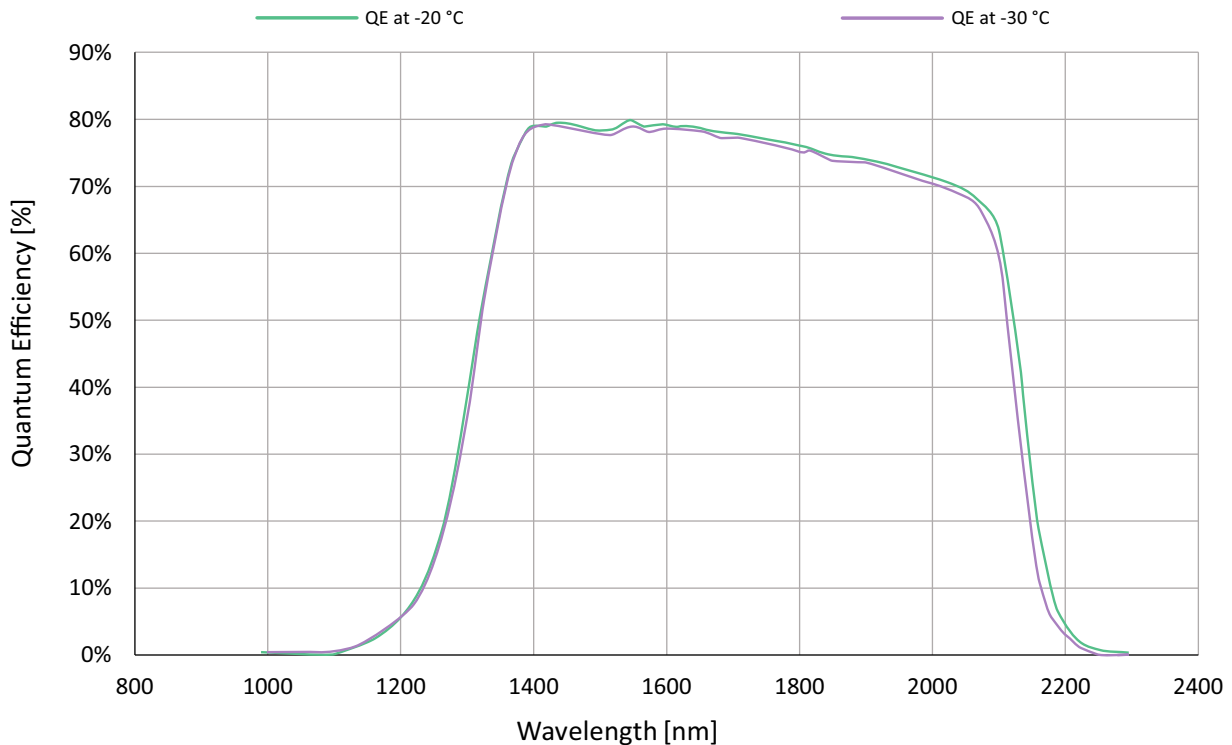

Figure 15: Goldeye G-034 XSWIR 2.2 TEC2 absolute QE

## Resolution and ROI frame rate



### Values when using MultiRegions features

When the camera is operated using more than a single ROI, values in this section may not be reached.

The maximum frame rate for Goldeye G-034 XSWIR 2.2 TEC2 is determined by the ROI size. Calculate the maximum frame rate using the following formula.

$$\text{FrameRate} = \frac{18,000,000}{\left[ (V + 1) \times \left( \frac{H}{8} + 36 \right) \right] + 254}$$

H	ROI: horizontal resolution (width). The formula is valid if $H \geq 32$ . For H always use the value rounded up to the next multiple of multiple of 32.
V	ROI: vertical resolution (height). The formula is valid if $V \geq 4$ . For V always use the value rounded up to the next multiple of 4.

When using the formula, please consider the following:

- Round the denominator up or down to the next full  $\mu$ s.
- Minimum ROI width is 8 pixels, minimum ROI height is 4 pixels.
- The formula generally outputs very exact values, however when the ROI approaches its minimum size, the accuracy decreases by some degree.
- Computational limitations of the host and image capture software may prevent the camera from achieving maximum frame rates.

*Formula 13: Maximum frame rate for Goldeye G-034 XSWIR 2.2 TEC2*

Examples for maximum frame rates with Goldeye G-034 XSWIR 2.2 TEC2 for common resolutions are listed in the following table.

Resolution		Format name	Maximum frame rate [fps] (Pixel format)	
Width	Height			
636	508	Sensor full resolution	303	(8-bit)
636	480	Approx. matches VGA format	321	(8-bit)
320	240	QVGA	968	(8-bit)
160	120	QQVGA	2557	(8-bit or 12-bit)
$\leq 128$	$\leq 24$	For all resolutions smaller than this, the frame rate remains the same.	>11627	(8-bit)

*Table 95: Goldeye G-034 XSWIR 2.2 TEC2 resolution and frame rates*

## Goldeye G-130 TEC1

### Imaging and performance

Parameter	Values
Sensor model	Sony IMX990 SenSWIR
Sensor type	InGaAs
Sensor format	Type 1/2 (8.2 mm diagonal)
Shutter type	Global shutter
Spectral range	400 nm to 1700 nm
Resolution (H × V)	1280 × 1024
Pixel size	5 μm × 5 μm
Sensor size (effective)	6.4 mm × 5.12 mm
Dark current (at +20 °C FPA temperature)	4.8 ke <sup>-</sup> /s
Temporal dark noise (0 dB)	250 e <sup>-</sup>
Temporal dark noise (18 dB)	210 e <sup>-</sup>
Saturation capacity (0 dB)	165 ke <sup>-</sup>
Saturation capacity (18 dB)	17.2 ke <sup>-</sup>
Dynamic range (0 dB)	56.4 dB
Dynamic range (18 dB)	38.2 dB
Pixel operability	>99.5%
Exposure time	18 μs to 200 ms <sup>1</sup> (Normal <sup>2</sup> )   3 μs to 7 μs (Ultrashort <sup>2</sup> )
Maximum frame rate at full resolution	84 fps (Continuous <sup>3</sup> )   94 fps (Recorder <sup>3</sup> )
Temperature control	Single-stage thermo-electric cooling (TEC1)
Analog gain factor	1 (0 dB), 7.9 (18 dB)
A/D converter	12-bit
Image buffer size	256 MB
Stream hold capacity	95 frames at full resolution
<sup>1</sup> Maximum exposure value given is valid for 0 dB and sensor temperature of +20 °C. Even longer exposures can be set, but the image quality may deteriorate.	
<sup>2</sup> Values for <code>ExposureRangeMode</code> = <i>Normal</i> or <i>Ultrashort</i>	
<sup>3</sup> Values for <code>AcquisitionMode</code> = <i>Continuous</i> or <i>Recorder</i>	

Table 96: Goldeye G-130 TEC1 imaging and performance

## Output

Parameter	Values
Digital interface	GigE Vision (based on IEEE 802.3 1000BASE-T)
Bit depth	8-bit to 12-bit
Pixel formats	Mono8, Mono12, Mono12Packed

*Table 97: Goldeye G-130 TEC1 output*

## GPIOs

Parameter	Values
Opto-isolated I/Os	1 input, 2 outputs
RS232	up to 115,200 bits per second, 8N1 (adjustable)
LVTTL I/Os	1 input, 1 output

*Table 98: Goldeye G-130 TEC1 GPIOs*

## Mechanics

Parameter	Values
Body dimensions (L × W × H) without lens mount adapter	78 mm × 55 mm × 55 mm
Lens mount	C-Mount
Mass, including lens mount	340 g

*Table 99: Goldeye G-130 TEC1 mechanics*

## Operating conditions

Parameter	Values
Operating temperature	-20 °C to +55 °C (housing)
Storage temperature	-30 °C to +70 °C (ambient)
Sensor cooling temperature, setpoints	<ul style="list-style-type: none"> <li>• +20 °C (default and calibrated)</li> <li>• +5 °C, +35 °C, +50 °C (uncalibrated)</li> <li>• User-configurable</li> </ul>
Relative humidity	10% to 95%, non-condensing
Power requirements (DC)	<ul style="list-style-type: none"> <li>• 10.8 V to 30.0 V</li> <li>• PoE (IEEE 802.3at Type 1 Class 0)</li> </ul>
Maximum power consumption	<ul style="list-style-type: none"> <li>• 10.8 W (12 VDC)</li> <li>• &lt;12.95 W (PoE)</li> </ul>
Typical power consumption without cooling	<ul style="list-style-type: none"> <li>• 6.1 W (12 VDC)</li> <li>• 7.4 W (PoE)</li> </ul>

Table 100: Goldeye G-130 TEC1 operating conditions

## Relative QE

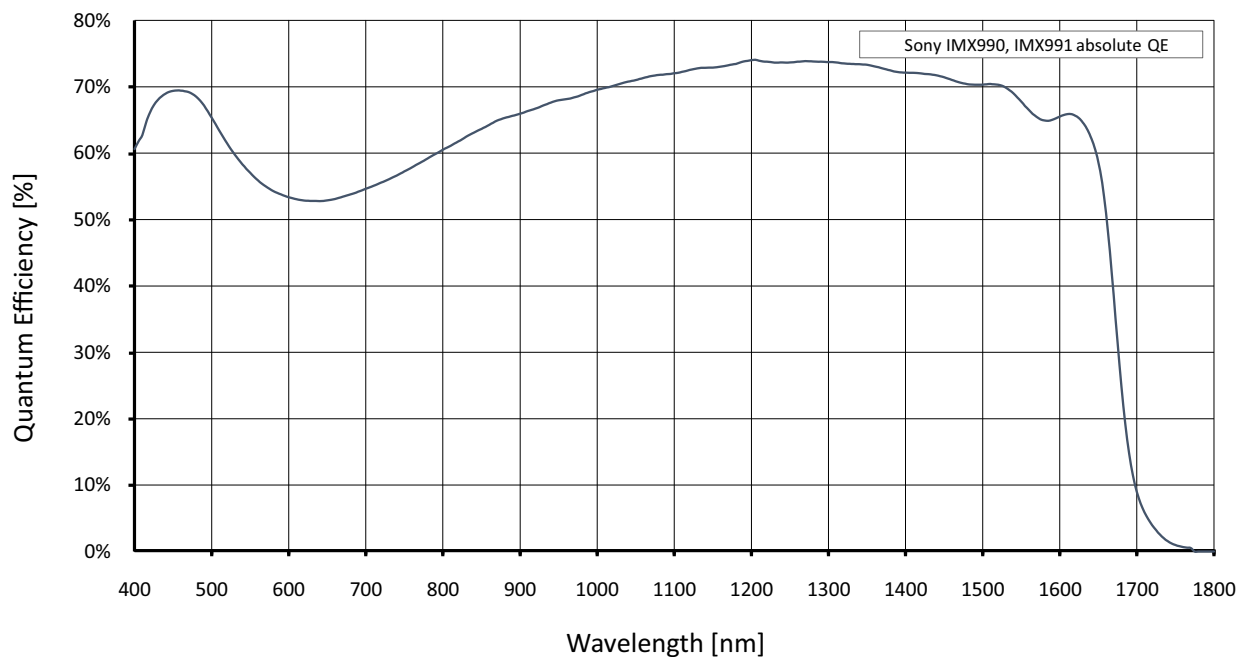

Figure 16: Goldeye G-130 TEC1 relative QE

## Resolution and ROI frame rates

The maximum frame rate for Goldeye G-130 TEC1 is determined by the ROI size. Calculate the maximum frame rate using the following formula.

$$\text{SensorFrameRate} = \frac{\text{PF}}{V + 36}$$

$$\text{GigEFrameRate} = \frac{\text{BW} \times 0,96}{V \times H \times \text{BPP}}$$

$$\text{FrameRate} = \text{MIN}(\text{SensorFrameRate}, \text{GigEFrameRate})$$

BPP	Bytes per pixel factor <ul style="list-style-type: none"> <li>• Mono8: 1</li> <li>• Mono12: 2</li> <li>• Mono12p: 1.5</li> </ul>
BW	Bandwidth, defined by DeviceThrouputLimit, typical: 115,000,000 Bps
H	ROI: vertical resolution (height). The formula is valid if $H \geq 8$ . For H always use the value rounded up to the next multiple of 8.
PF	Pixel format factor <ul style="list-style-type: none"> <li>• Mono8: 99734.04</li> <li>• Mono12: 75604.84</li> <li>• Mono12p: 75604.84</li> </ul>
V	ROI: vertical resolution (height). The formula is valid if $V \geq 8$ . For V always use the value rounded up to the next multiple of 8.

When using the formula, please consider the following:

- The formula serves as a rough estimation.
- Valid for IntegrateWhileRead-Mode only.
- ROI minimum width and height are 8 pixels.
- Exposure time may reduce the frame rate.
- Computational limitations of the host and image capture software may prevent the camera from achieving maximum frame rates.

*Formula 14: Maximum frame rate for Goldeye G-130 TEC1*

Examples for maximum frame rates with Goldeye G-130 TEC1 for common resolutions are listed in the following table.

Resolution		Format name	Maximum frame rate [fps]	
Width	Height		Sensor <sup>1</sup>	GigE <sup>2</sup>
1280	1024	Sensor full resolution, matches SXGA format	94	84
1280	720	HD 720	131	119
1024	768	XGA	124	
800	600	SVGA	156	
640	480	VGA	193	
320	240	QVGA	361	
160	120	QQVGA	639	
1280	512	Maximum × half	181	168
1280	8	Maximum × minimum	2266	
8	512	Minimum × maximum	179	
8	8	Minimum × minimum	2266	

<sup>1</sup>For AcquisitionMode = Recorder

<sup>2</sup>For DeviceThroughputLimit = 115 000 000 Bps (115 MBps)

Table 101: Goldeye G-130 TEC1 resolution and frame rates

# Specifications (CL models)

## Goldeye CL-008 TEC1

### Imaging and performance

Parameter	Values
Sensor	InGaAs, progressive scan, electronic full frame shutter
Sensor type	FPA
Spectral range	900 nm to 1700 nm
Resolution (H × V)	320 × 256
Pixel size	30 μm × 30 μm
Sensor size (effective)	9.6 mm × 7.68 mm
Dark current	880 ke <sup>-</sup> /s <sup>1</sup>
Temporal dark noise (Gain0)	1.6 ke <sup>-</sup> <sup>1</sup>
Temporal dark noise (Gain1)	210 e <sup>-</sup> <sup>1</sup>
Saturation capacity (Gain0)	5.0 Me <sup>-</sup> <sup>1</sup>
Saturation capacity (Gain1)	170 ke <sup>-</sup> <sup>1</sup>
Dynamic range (Gain0)	70 dB <sup>1</sup>
Dynamic range (Gain1)	60 dB <sup>1</sup>
Pixel operability	>99.5%
Maximum frame rate at full resolution	344 fps
Exposure time	6 μs to 200 ms <sup>2</sup>
Temperature control	Single-stage thermo-electric cooling and heating (TEC1)
Analog gain factor	1 (Gain0), 15 (Gain1)
A/D converter	14-bit
Image buffer size	256 MB
Stream hold capacity	1524 frames at full resolution
<sup>1</sup> Typical values that were determined similar to EMVA 1288 v4.0 (Linear model) under 1200 nm LED illumination. Stated values are mean values of multiple different measurements at +25 °C FPA temperature, if not stated otherwise.	
<sup>2</sup> Maximum exposure value given is valid for Gain0 and sensor temperature of +25 °C. Even longer exposures can be set, but the image quality may deteriorate.	

Table 102: Goldeye CL-008 TEC1 imaging and performance



## Output

Parameter	Values
Digital interface	Camera Link Base, up to 2 taps, 40 MHz, SDR-26 connector, Serial Control Channel
Bit depth	8-bit to 16-bit
Pixel formats	<ul style="list-style-type: none"> <li>Tap geometry 1X 1Y: Mono8, Mono10, Mono12, Mono14, Mono16</li> <li>Tap geometry 1X2 1Y: Mono8, Mono10, Mono12</li> </ul>

Table 103: Goldeye CL-008 TEC1 output

## GPIOs

Parameter	Values
Opto-isolated I/Os	1 input, 2 outputs
RS232	up to 115,200 bits per second, 8N1 (adjustable)
LVTTTL I/Os	1 input, 1 output
LVDS inputs	CC1- CC4

Table 104: Goldeye CL-008 TEC1 GPIOs

## Mechanics

Parameter	Values
Body dimensions (L × W × H) without lens adapter	78 mm × 55 mm × 55 mm
Lens mounts	C-Mount, F-Mount, M42-Mount
Mass, without adapter	300 g
Mass, with C-Mount adapter	320 g
Mass, with F-Mount adapter	370 g
Mass, with M42-Mount adapter	340 g

Table 105: Goldeye CL-008 TEC1 mechanics

## Operating conditions

Parameter	Values
Operating temperature	-20 °C to +55 °C (housing)
Storage temperature	-30 °C to +70 °C (ambient)
Temperature setpoints <sup>1</sup>	<ul style="list-style-type: none"> <li>+25 °C (default and calibrated)</li> <li>+20 °C, +35 °C, +50 °C (uncalibrated)</li> <li>User-configurable</li> </ul>
Relative humidity	10% to 95%, non-condensing
Power requirements (DC)	10.8 V to 30.0 V
Maximum power consumption	10 W (12 VDC)
Typical power consumption without cooling	4.5 W (12 VDC)

<sup>1</sup> Even though the first temperature setpoint is pre-configured to +20 °C, it is possible to set it to a lower temperature. However, if the sensor temperature is lower than the ambient temperature, especially in humid environments, condensation may occur.

Table 106: Goldeye CL-008 TEC1 operating conditions

## Absolute QE

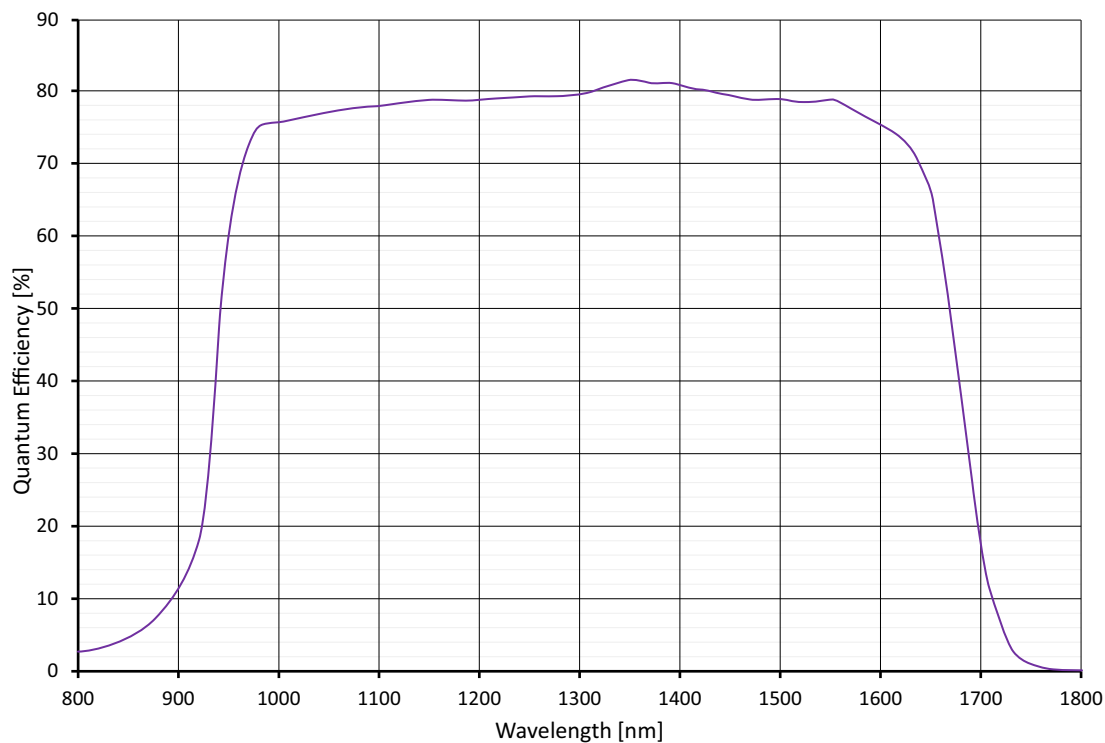

Figure 17: Goldeye CL-008 TEC1 absolute QE

## Resolution and ROI frame rates

The maximum frame rate for Goldeye CL-008 TEC1 is determined by the ROI size. Calculate the maximum frame rate using the following formula..

$$\text{SensorFrameRate} = \frac{10,000,000}{\left[ (V + 2) \times \left( \frac{H}{4} + 32 \right) \right] + 171}$$

H	ROI: horizontal resolution (width). The formula is valid if $H \geq 128$ . For H always use the value rounded up to the next multiple of 8.
V	ROI: vertical resolution (height). The formula is valid if $V \geq 8$ . For V always use the value rounded up to the next multiple of 2.

When using the formula, please consider the following:

- Round the denominator down to the next full  $\mu\text{s}$ .
- Minimum ROI width is 8 pixels, minimum ROI height is 4 pixels.
- The formula generally outputs very exact values, however when the ROI approaches its minimum size, the accuracy decreases by some degree.
- Computational limitations of the host and image capture software may prevent the camera from achieving maximum frame rates.

$$\text{CameraLinkFrameRate} = \frac{\text{CIFrequency}}{\left[ \max((3 \times H + 32), A) + \left( \frac{H}{\text{Taps}} + B \right) (V - 1) + \left( \frac{H}{\text{Taps}} \right) + C + D \right]}$$

A	CI Min FVal To LVal Delay
B	CI LVal To LVal Delay
C	CI LVal To FVal Delay
D	CI Min FVal To FVal Delay

$$\text{FrameRate} = \min(\text{SensorFrameRate}, \text{CameraLinkFrameRate})$$

*Formula 15: Maximum frame rate for Goldeye CL-008 TEC1*

### Frame rates by pixel format, clock frequency, and number of taps

Examples for maximum frame rates with Goldeye CL-008 TEC1 for common resolutions are listed in the following table.

Resolution		25 MHz		40 MHz	
Width	Height	Mono8/12, 2 Taps	Mono14, 1 Tap	Mono8/12, 2 Taps	Mono14, 1 Tap
320	256	344	274	344	344
320	240	366	292	366	366
160	120	1117	1059	1117	1117
128	32	4273	4273	4273	4273
128	8	12345	12345	12345	12345

*Table 107: Goldeye CL-008 TEC1 frame rates by pixel format, clock frequency, and number of taps*

## Goldeye CL-008 Cool TEC1

### Imaging and performance

Parameter	Values
Sensor	InGaAs, progressive scan, electronic full frame shutter
Sensor type	FPA
Spectral range	900 nm to 1700 nm
Resolution (H × V)	320 × 256
Pixel size	30 μm × 30 μm
Sensor size (effective)	9.6 mm × 7.68 mm
Dark current	260 ke <sup>-</sup> /s <sup>1</sup>
Temporal dark noise (Gain0)	1.6 ke <sup>-</sup> <sup>1</sup>
Temporal dark noise (Gain1)	210 e <sup>-</sup> <sup>1</sup>
Saturation capacity (Gain0)	5.0 Me <sup>-</sup> <sup>1</sup>
Saturation capacity (Gain1)	170 ke <sup>-</sup> <sup>1</sup>
Dynamic range (Gain0)	70 dB <sup>1</sup>
Dynamic range (Gain1)	60 dB <sup>1</sup>
Pixel operability	>99.5% <sup>1</sup>
Maximum frame rate at full resolution	344 fps
Exposure time	6 μs to 1250 ms <sup>2</sup>
Temperature control	Single-stage thermo-electric cooling and heating (TEC1)
Analog gain factor	1 (Gain0), 15 (Gain1)
A/D converter	14-bit
Image buffer size	256 MB
Stream hold capacity	1524 frames at full resolution
<sup>1</sup> Typical values that were determined similar to EMVA 1288 v4.0 (Linear model) under 1200 nm LED illumination. Stated values are mean values of multiple different measurements at +5 °C FPA temperature, if not stated otherwise.	
<sup>2</sup> Maximum exposure value given is valid for Gain0 and sensor temperature of +5 °C. Even longer exposures can be set, but the image quality may deteriorate.	

Table 108: Goldeye CL-008 Cool TEC1 imaging and performance

## Output

Parameter	Values
Digital interface	Camera Link Base, up to 2 taps, 40 MHz, SDR-26 connector, Serial Control Channel
Bit depth	8-bit to 16-bit
Pixel formats	<ul style="list-style-type: none"> <li>Tap geometry 1X 1Y: Mono8, Mono10, Mono12, Mono14, Mono16</li> <li>Tap geometry 1X2 1Y: Mono8, Mono10, Mono12</li> </ul>

Table 109: Goldeye CL-008 Cool TEC1 output

## GPIOs

Parameter	Values
Opto-isolated I/Os	1 input, 2 outputs
RS232	up to 115,200 bits per second, 8N1 (adjustable)
LVTTTL I/Os	1 input, 1 output
LVDS inputs	CC1- CC4

Table 110: Goldeye CL-008 Cool TEC1 GPIOs

## Mechanics

Parameter	Values
Body dimensions (L × W × H) without lens adapter	90 mm × 80 mm × 80 mm
Lens mounts	<ul style="list-style-type: none"> <li>C-Mount</li> <li>F-Mount and M42-Mount available on request</li> </ul>
Mass, without adapter	740 g
Mass, with C-Mount adapter	760 g
Mass, with F-Mount adapter	820 g
Mass, with M42-Mount adapter	780 g

Table 111: Goldeye CL-008 Cool TEC1 mechanics

## Operating conditions

Parameter	Values
Operating temperature	-20 °C to +55 °C (housing)
Storage temperature	-30 °C to +70 °C (ambient)
Sensor cooling temperature, setpoints	<ul style="list-style-type: none"> <li>+5 °C (default and calibrated)</li> <li>-5 °C, +10 °C, +20 °C (uncalibrated)</li> <li>User-configurable</li> </ul>
Relative humidity	10% to 95%, non-condensing
Power requirements (DC)	10.8 V to 30.0 V
Maximum power consumption	10.5 W (12 VDC)
Typical power consumption without cooling	5.0 W (12 VDC)

Table 112: Goldeye CL-008 Cool TEC1 operating conditions

## Absolute QE

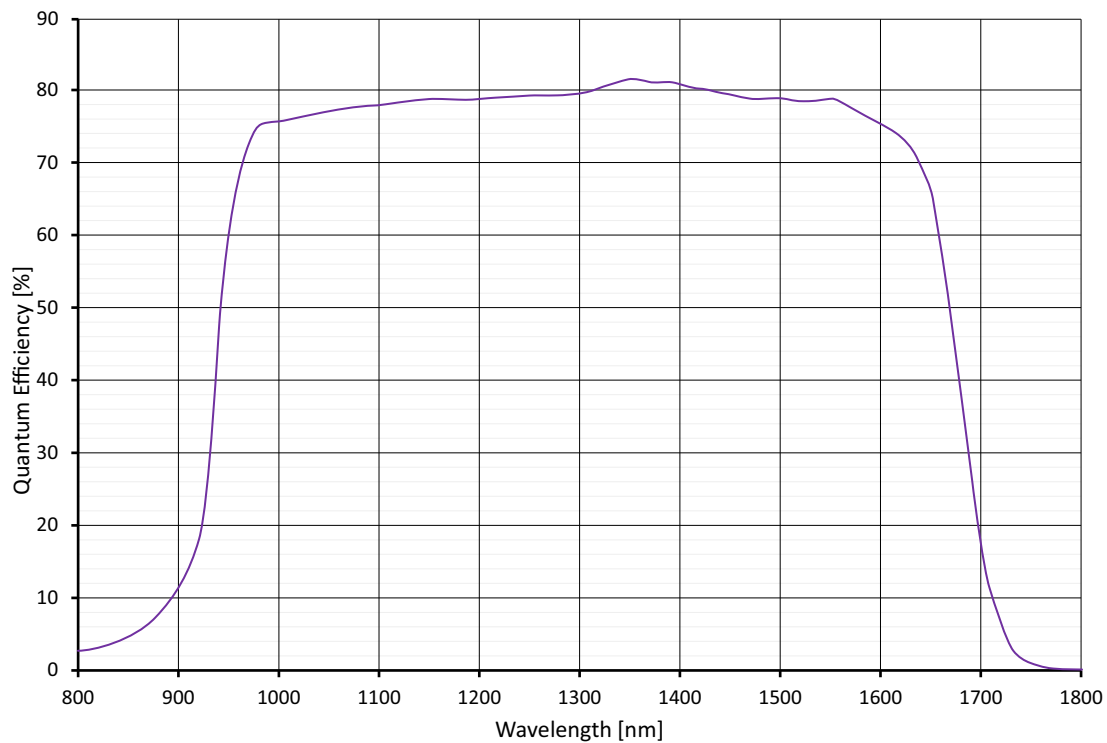

Figure 18: Goldeye CL-008 Cool TEC1 absolute QE

## Resolution and ROI frame rates

The maximum frame rate for Goldeye CL-008 Cool TEC1 is determined by the ROI size. Calculate the maximum frame rate using the following formulas.

$$\text{SensorFrameRate} = \frac{10,000,000}{\left[ (V + 2) \times \left( \frac{H}{4} + 32 \right) \right] + 171}$$

H	ROI: horizontal resolution (width). The formula is valid if $H \geq 128$ . For H always use the value rounded up to the next multiple of 8.
V	ROI: vertical resolution (height). The formula is valid if $V \geq 8$ . For V always use the value rounded up to the next multiple of 2.

When using the formula, please consider the following:

- Round the denominator down to the next full  $\mu\text{s}$ .
- Minimum ROI width is 8 pixels, minimum ROI height is 4 pixels.
- The formula generally outputs very exact values, however when the ROI approaches its minimum size, the accuracy decreases by some degree.
- Computational limitations of the host and image capture software may prevent the camera from achieving maximum frame rates.

$$\text{CameraLinkFrameRate} = \frac{\text{CIFrequency}}{\left[ \max((3 \times H + 32), A) + \left( \frac{H}{\text{Taps}} + B \right) (V - 1) + \left( \frac{H}{\text{Taps}} \right) + C + D \right]}$$

A	CIMinFValToLValDelay
B	CLLValToLValDelay
C	CLLValToFValDelay
D	CIMinFValToFValDelay

$$\text{FrameRate} = \min(\text{SensorFrameRate}, \text{CameraLinkFrameRate})$$

*Formula 16: Maximum frame rate for Goldeye CL-008 Cool TEC1*



### ROI frame rates with different setups

Examples for maximum frame rates with Goldeye CL-008 Cool TEC1 for common resolutions are listed in the following table.

Resolution		25 MHz		40 MHz	
Width	Height	Mono8/12, 2 Taps	Mono14, 1 Tap	Mono8/12, 2 Taps	Mono14, 1 Tap
320	256	344	274	344	344
320	240	366	292	366	366
160	120	1117	1059	1117	1117
128	32	4273	4273	4273	4273
128	8	12345	12345	12345	12345

*Table 113: Goldeye CL-008 Cool TEC1 ROI frame rates by pixel format, clock frequency, and number of taps*

## Goldeye CL-008 XSWIR 1.9 TEC2

### Imaging and performance

Parameter	Values
Sensor	InGaAs, progressive scan, electronic full frame shutter
Sensor type	FPA
Spectral range	1100 nm to 1900 nm
Resolution (H × V)	320 × 256
Pixel size	30 μm × 30 μm
Sensor size (effective)	9.6 mm × 7.68 mm
Dark current	1.2 Me <sup>-</sup> /s <sup>1</sup>
Temporal dark noise (Gain0)	1.8 ke <sup>-</sup> <sup>1</sup>
Temporal dark noise (Gain1)	200 e <sup>-</sup> <sup>1</sup>
Saturation capacity (Gain0)	5.0 Me <sup>-</sup> <sup>1</sup>
Saturation capacity (Gain1)	140 ke <sup>-</sup> <sup>1</sup>
Dynamic range (Gain0)	68 dB <sup>1</sup>
Dynamic range (Gain1)	57 dB <sup>1</sup>
Pixel operability	>98.5%
Maximum frame rate at full resolution	344 fps
Exposure time	6 μs to 30 ms <sup>2</sup>
Temperature control	Dual-stage thermo-electric cooling (TEC2)
Analog gain factor	1 (Gain0), 15 (Gain1)
A/D converter	14-bit
Image buffer size	256 MB
Stream hold capacity	1524 frames at full resolution
<sup>1</sup> Typical values that were determined similar to EMVA 1288 v4.0 (Linear model) under 1200 nm LED illumination. Stated values are mean values of multiple different measurements at -30 °C FPA temperature, if not stated otherwise.	
<sup>2</sup> Maximum exposure value given is valid for Gain0 and sensor temperature of -30 °C. Even longer exposures can be set, but the image quality may deteriorate.	

Table 114: Goldeye CL-008 XSWIR 1.9 TEC2 imaging and performance

## Output

Parameter	Values
Digital interface	Camera Link Base, up to 2 taps, 85 MHz, SDR-26 connector, Serial Control Channel
Bit depth	8-bit to 16-bit
Pixel formats	<ul style="list-style-type: none"> <li>Tap geometry 1X 1Y: Mono8, Mono10, Mono12, Mono14, Mono16</li> <li>Tap geometry 1X2 1Y: Mono8, Mono10, Mono12</li> </ul>

Table 115: Goldeye CL-008 XSWIR 1.9 TEC2 output

## GPIOs

Parameter	Values
Opto-isolated I/Os	1 input, 2 outputs
RS232	up to 115,200 bits per second, 8N1 (adjustable)
LVTTTL I/Os	1 input, 1 output
LVDS inputs	CC1- CC4

Table 116: Goldeye CL-008 XSWIR 1.9 TEC2 GPIOs

## Mechanics

Parameter	Values
Body dimensions (L × W × H) without lens mount adapter	90 mm × 80 mm × 80 mm
Lens mount	C-Mount
Mass, including lens mount	730 g

Table 117: Goldeye CL-008 XSWIR 1.9 TEC2 mechanics

### Operating conditions

Parameter	Values
Operating temperature	-20 °C to +55 °C (housing)
Storage temperature	-30 °C to +70 °C (ambient)
Sensor cooling temperature, setpoints	<ul style="list-style-type: none"> <li>• -30°C (default and calibrated)</li> <li>• -20 °C (calibrated)</li> <li>• -10 °C, 0 °C (uncalibrated)</li> <li>• User-configurable</li> </ul>
Relative humidity	10% to 95%, non-condensing
Power requirements (DC)	10.8 V to 30.0 V
Maximum power consumption	20 W (12 VDC)
Typical power consumption without cooling	5 W (12 VDC)

*Table 118: Goldeye CL-008 XSWIR 1.9 TEC2 operating conditions*

## Absolute QE



### Quantum efficiency for various sensor temperature values

The following curves relate to a sensor temperatures of -20 °C and -30 °C default, the sensitivity is slightly shifted to lower wave lengths, but the range is maintained. With increased sensor temperatures, the QE curve is slightly shifted to longer wavelengths, and for lower temperatures it is shifted to shorter wavelengths.

See the corresponding application note at [www.alliedvision.com/fileadmin/content/documents/products/cameras/Goldeye\\_2/appnote/Goldeye-G-CL\\_AppNote\\_Temperature-Influence-on-Image-Quality\\_en.pdf](http://www.alliedvision.com/fileadmin/content/documents/products/cameras/Goldeye_2/appnote/Goldeye-G-CL_AppNote_Temperature-Influence-on-Image-Quality_en.pdf).

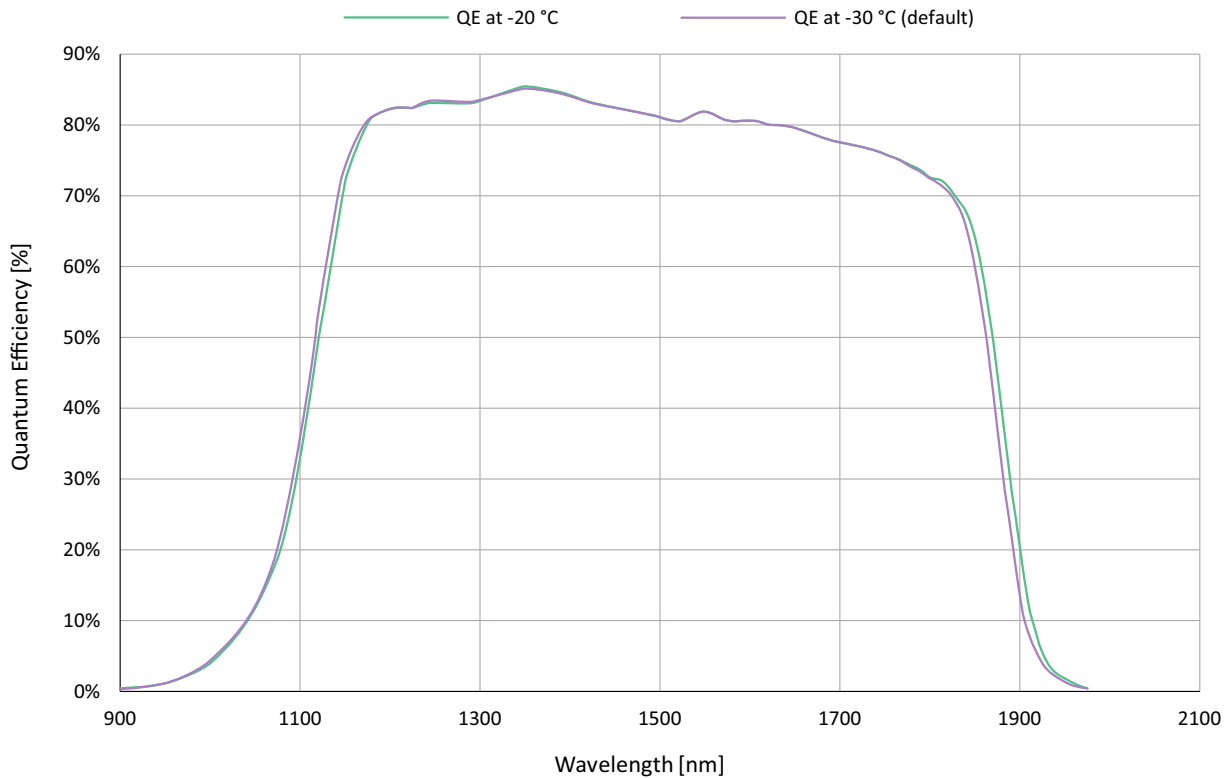

Figure 19: Goldeye CL-008 XSWIR 1.9 TEC2 absolute QE

## Resolution and ROI frame rate



### Values when using MultiRegions features

When the camera is operated using more than a single ROI, values in this section may not be reached.

The maximum frame rate for Goldeye CL-008 XSWIR 1.9 TEC2 is determined by the ROI size. Calculate the maximum frame rate using the following formulas.

$$\text{SensorFrameRate} = \frac{18,000,000}{\left[ (V + 1) \times \left( \frac{H}{8} + 36 \right) \right] + 254}$$

H	ROI: horizontal resolution (width). The formula is valid if $H \geq 128$ . For H always use the value rounded up to the next multiple of 32.
V	ROI: vertical resolution (height). The formula is valid if $V \geq 8$ . For V always use the value rounded up to the next multiple of 4.

When using the formula, please consider the following:

- Round the denominator up or down to the next full  $\mu\text{s}$ .
- Minimum ROI width is 8 pixels, minimum ROI height is 4 pixels.
- The formula generally outputs very exact values, however when the ROI approaches its minimum size, the accuracy decreases by some degree.
- Computational limitations of the host and image capture software may prevent the camera from achieving maximum frame rates.

$$\text{CameraLinkFrameRate} = \frac{\text{CIFrequency}}{\left[ \max((3 \times H + 32), A) + \left( \frac{H}{\text{Taps}} + B \right) (V - 1) + \left( \frac{H}{\text{Taps}} \right) + C + D \right]}$$

$$\text{FrameRate} = \min(\text{SensorFrameRate}, \text{CameraLinkFrameRate})$$

A	CIMinFValToLValDelay)
B	CLLValToLValDelay
C	CLLValToFValDelay
D	CIMinFValToFValDelay

*Formula 17: Maximum frame rate for Goldeye CL-008 XSWIR 1.9 TEC2*

Examples for maximum frame rates with Goldeye CL-008 XSWIR 1.9 TEC2 for common resolutions are listed in the following table following table.

Resolution		25 MHz		40 MHz	
Width	Height	Mono8/12, 2 Taps	Mono14, 1 Tap	Mono8/12, 2 Taps	Mono14, 1 Tap
320	256	344	270	344	344
320	240	366	288	366	366
160	120	1117	1035	1117	1117
128	32	4273	4140	4260	4260
128	8	12345	12000	11149	11800

*Table 119: Goldeye CL-008 XSWIR 1.9 TEC2 ROI frame rates by pixel format, clock frequency, and number of taps*

## Goldeye CL-008 XSWIR 2.2 TEC2

### Imaging and performance

Parameter	Values
Sensor	InGaAs, progressive scan, electronic full frame shutter
Sensor type	FPA
Spectral range	1200 nm to 2200 nm
Resolution (H × V)	320 × 256
Pixel size	30 μm × 30 μm
Sensor size (effective)	9.6 mm × 7.68 mm
Dark current	15.3 Me <sup>-</sup> /s <sup>1</sup>
Temporal dark noise (Gain0)	2.5 ke <sup>-</sup> <sup>1</sup>
Temporal dark noise (Gain1)	200 e <sup>-</sup> <sup>1</sup>
Saturation capacity (Gain0)	5.0 Me <sup>-</sup> <sup>1</sup>
Saturation capacity (Gain1)	110 ke <sup>-</sup> <sup>1</sup>
Dynamic range (Gain0)	68 dB <sup>1</sup>
Dynamic range (Gain1)	57 dB <sup>1</sup>
Pixel operability	>98.5%
Maximum frame rate at full resolution	64 dB <sup>1</sup>
Exposure time	6 μs to 7 ms <sup>2</sup>
Temperature control	Dual-stage thermo-electric cooling (TEC2)
Analog gain factor	1 (Gain0), 15 (Gain1)
A/D converter	14-bit
Image buffer size	256 MB
Stream hold capacity	1524 frames at full resolution
<sup>1</sup> Typical values that were determined similar to EMVA 1288 v4.0 (Linear model) under 1485 nm LED illumination. Stated values are mean values of multiple different measurements at -30 °C FPA temperature, if not stated otherwise.	
<sup>2</sup> Maximum exposure value given is valid for Gain0 and sensor temperature of -30 °C. Even longer exposures can be set, but the image quality may deteriorate.	

Table 120: Goldeye CL-008 XSWIR 2.2 TEC2 imaging and performance



## Output

Parameter	Values
Digital interface	Camera Link Base, up to 2 taps, 85 MHz, SDR-26 connector, Serial Control Channel
Bit depth	8-bit to 16-bit
Pixel formats	<ul style="list-style-type: none"> <li>Tap geometry 1X 1Y: Mono8, Mono10, Mono12, Mono14, Mono16</li> <li>Tap geometry 1X2 1Y: Mono8, Mono10, Mono12</li> </ul>

Table 121: Goldeye CL-008 XSWIR 2.2 TEC2 output

## GPIOs

Parameter	Values
Opto-isolated I/Os	1 input, 2 outputs
RS232	up to 115,200 bits per second, 8N1 (adjustable)
LVTTTL I/Os	1 input, 1 output
LVDS inputs	CC1- CC4

Table 122: Goldeye CL-008 XSWIR 2.2 TEC2 GPIOs

## Mechanics

Parameter	Values
Body dimensions (L × W × H) without lens mount adapter	90 mm × 80 mm × 80 mm
Lens mount	C-Mount
Mass, including lens mount	730 g

Table 123: Goldeye CL-008 XSWIR 2.2 TEC2 mechanics

### Operating conditions

Parameter	Values
Operating temperature	-20 °C to +55 °C (housing)
Storage temperature	-30 °C to +70 °C (ambient)
Sensor cooling temperature, setpoints	<ul style="list-style-type: none"> <li>• -30 °C (default and calibrated)</li> <li>• -20 °C, -10 °C, 0 °C (uncalibrated)</li> <li>• User-configurable</li> </ul>
Relative humidity	10% to 95%, non-condensing
Power requirements (DC)	10.8 V to 30.0 V
Maximum power consumption	20 W (12 VDC)
Typical power consumption without cooling	5 W (12 VDC)

*Table 124: Goldeye CL-008 XSWIR 2.2 TEC2 operating conditions*

## Absolute QE



### Quantum efficiency for various sensor temperature values

The following curves relate to a sensor temperatures of -20 °C and -30 °C default, the sensitivity is slightly shifted to lower wave lengths, but the range is maintained. With increased sensor temperatures, the QE curve is slightly shifted to longer wavelengths, and for lower temperatures it is shifted to shorter wavelengths.

See the corresponding application note at [www.alliedvision.com/fileadmin/content/documents/products/cameras/Goldeye\\_2/appnote/Goldeye-G-CL\\_AppNote\\_Temperature-Influence-on-Image-Quality\\_en.pdf](http://www.alliedvision.com/fileadmin/content/documents/products/cameras/Goldeye_2/appnote/Goldeye-G-CL_AppNote_Temperature-Influence-on-Image-Quality_en.pdf).

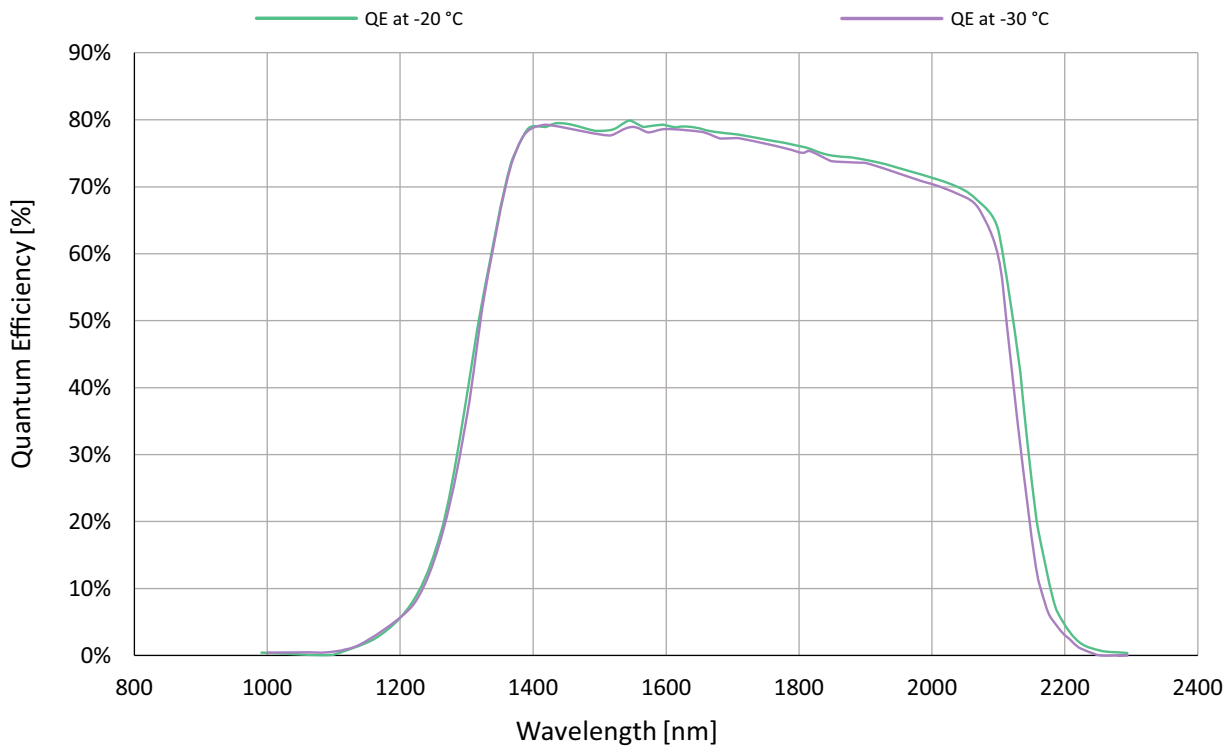

Figure 20: Goldeye CL-008 XSWIR 2.2 TEC2 absolute QE

## Resolution and ROI frame rate



### Values when using MultiRegions features

When the camera is operated using more than a single ROI, values in this section may not be reached.

The maximum frame rate for Goldeye CL-008 XSWIR 2.2 TEC2 is determined by the ROI size. Calculate the maximum frame rate using the following formulas.

$$\text{SensorFrameRate} = \frac{18,000,000}{\left[ (V + 1) \times \left( \frac{H}{8} + 36 \right) \right] + 254}$$

H	ROI: horizontal resolution (width). The formula is valid if $H \geq 128$ . For H always use the value rounded up to the next multiple of 32.
V	ROI: vertical resolution (height). The formula is valid if $V \geq 8$ . For V always use the value rounded up to the next multiple of 4.

When using the formula, please consider the following:

- Round the denominator up or down to the next full  $\mu\text{s}$ .
- Minimum ROI width is 8 pixels, minimum ROI height is 4 pixels.
- The formula generally outputs very exact values, however when the ROI approaches its minimum size, the accuracy decreases by some degree.
- Computational limitations of the host and image capture software may prevent the camera from achieving maximum frame rates.

$$\text{CameraLinkFrameRate} = \frac{\text{CIFrequency}}{\left[ \max((3 \times H + 32), A) + \left( \frac{H}{\text{Taps}} + B \right) (V - 1) + \left( \frac{H}{\text{Taps}} \right) + C + D \right]}$$

$$\text{FrameRate} = \min(\text{SensorFrameRate}, \text{CameraLinkFrameRate})$$

A	CIMinFValToLValDelay)
B	CLLValToLValDelay
C	CLLValToFValDelay
D	CIMinFValToFValDelay

*Formula 18: Maximum frame rate for Goldeye CL-008 XSWIR 2.2 TEC2*

Examples for maximum frame rates with Goldeye CL-008 XSWIR 2.2 TEC2 for common resolutions are listed in the following table.

Resolution		25 MHz		40 MHz	
Width	Height	Mono8/12, 2 Taps	Mono14, 1 Tap	Mono8/12, 2 Taps	Mono14, 1 Tap
320	256	344	270	344	344
320	240	366	288	366	366
160	120	1117	1035	1117	1117
128	32	4273	4140	4260	4260
128	8	12345	12000	11149	11800

*Table 125: Goldeye CL-008 XSWIR 2.2 TEC2 ROI frame rates by pixel format, clock frequency, and number of taps*

## Goldeye CL-030 TEC1

### Imaging and performance

Parameter	Values
Sensor model	Sony IMX991 SenSWIR
Sensor type	InGaAs
Sensor format	Type 1/4 (4.1 mm diagonal)
Shutter type	Global shutter
Spectral range	400 nm to 1700 nm
Resolution (H × V)	656 × 520
Pixel size	5 μm × 5 μm
Sensor size (effective)	3.28 mm × 2.6 mm
Dark current (at +20 °C FPA temperature)	4.8 ke <sup>-</sup> /s
Temporal dark noise (0 dB)	250 e <sup>-</sup>
Temporal dark noise (18 dB)	210 e <sup>-</sup>
Saturation capacity (0 dB)	165 ke <sup>-</sup>
Saturation capacity (18 dB)	17.2 ke <sup>-</sup>
Dynamic range (0 dB)	56.4 dB
Dynamic range (18 dB)	38.2 dB
Pixel operability	>99.5%
Exposure time	16 μs to 200 ms <sup>1</sup> (Normal <sup>2</sup> )   3 μs to 7 μs (Ultrashort <sup>2</sup> )
Maximum frame rate at full resolution	234 fps
Temperature control	Single-stage thermo-electric cooling (TEC1)
Analog gain factor	1 (0 dB), 7.9 (18 dB)
A/D converter	12-bit
Image buffer size	256 MB
Stream hold capacity	370 frames at full resolution
<sup>1</sup> Maximum exposure value given is valid for 0 dB and sensor temperature of +20 °C. Even longer exposures can be set, but the image quality may deteriorate.	
<sup>2</sup> Values for ExposureRangeMode = <i>Normal</i> or <i>Ultrashort</i>	

Table 126: Goldeye CL-030 TEC1 imaging and performance

## Output

Parameter	Values
Digital interface	Camera Link Base, up to 2 taps, 40 MHz, SDR-26 connector, Serial Control Channel
Bit depth	8-bit to 12-bit
Pixel formats	<ul style="list-style-type: none"> <li>Tap geometry 1X 1Y: Mono8, Mono12</li> <li>Tap geometry 1X2 1Y: Mono8, Mono12</li> </ul>

Table 127: Goldeye CL-030 TEC1 output

## GPIOs

Parameter	Values
Opto-isolated I/Os	1 input, 2 outputs
RS232	up to 115,200 bits per second, 8N1 (adjustable)
LVTTL I/Os	1 input, 1 output
LVDS inputs	CC1- CC4

Table 128: Goldeye CL-030 TEC1 GPIOs

## Mechanics

Parameter	Values
Body dimensions (L × W × H) without lens mount adapter	78 mm × 55 mm × 55 mm
Lens mount	C-Mount
Mass, including lens mount	330 g

Table 129: Goldeye CL-030 TEC1 mechanics

## Operating conditions

Parameter	Values
Operating temperature	-20 °C to +55 °C (housing)
Storage temperature	-30 °C to +70 °C (ambient)
Temperature setpoints <sup>1</sup>	<ul style="list-style-type: none"> <li>+20 °C (default and calibrated)</li> <li>+5 °C, +35 °C, +50 °C (uncalibrated)</li> <li>User-configurable</li> </ul>
Relative humidity	10% to 95%, non-condensing
Power requirements (DC)	10.8 V to 30.0 V
Maximum power consumption	11.8 W (12 VDC)
Typical power consumption without cooling	5.4 W (12 VDC)

Table 130: Goldeye CL-030 TEC1 operating conditions

## Relative QE

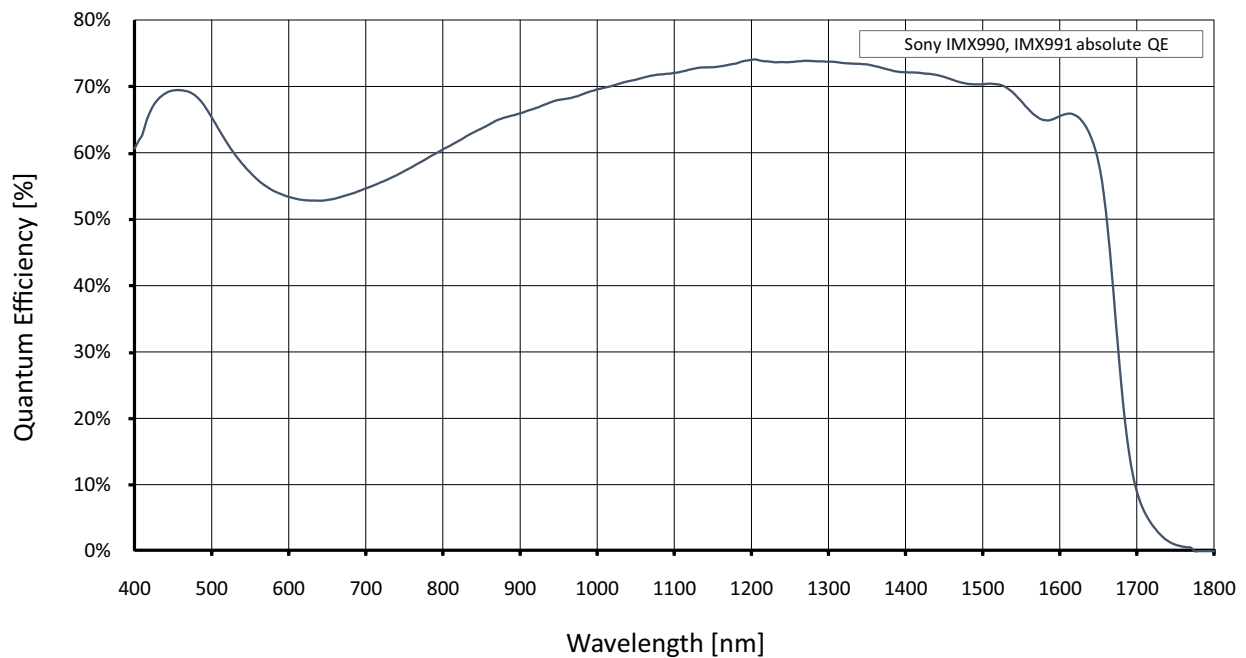

Figure 21: Goldeye CL-030 TEC1 relative QE



## Resolution and ROI frame rates

The maximum frame rate for Goldeye CL-030 TEC1 is determined by the ROI size. Calculate the maximum frame rate using the following formulas.

$$\text{SensorFrameRate} = \frac{\text{PF}}{V + 36}$$

PF	Pixel format factor <ul style="list-style-type: none"> <li>• Mono8: 130208.33</li> <li>• Mono12: 75604.84</li> <li>• Mono12p: 75604.84</li> </ul>
V	ROI: vertical resolution (height). The formula is valid if $V \geq 8$ . For V always use the value rounded up to the next multiple of 8.

When using the formula, please consider the following:

- The formula serves as a rough estimation.
- Valid for IntegrateWhileRead-Mode only.
- ROI minimum width and height are 8 pixels.
- Exposure time may reduce the frame rate.
- Computational limitations of the host and image capture software may prevent the camera from achieving maximum frame rates.

*Formula 19: Maximum frame rate for Goldeye CL-030 TEC1*

### ROI frame rates with different setups

Examples for maximum frame rates with Goldeye CL-030 TEC1 for common resolutions, are listed in the following tables.

Resolution		Mono8 (2 Taps)			Mono8 (1 Tap)		
Width	Height	25 MHz	55 MHz	85 MHz	25 MHz	55 MHz	85 MHz
656	520	120	234	234	66	145	224
640	480	132	252	252	73	160	248
320	240	447	471	471	265	471	471
160	120	834	834	834	834	834	834
656	264	231	433	433	128	282	433
656	8	2958	2958	2958	2469	2958	2958
8	520	234	234	234	234	234	234
8	8	2958	2958	2958	2958	2958	2958

Table 131: Goldeye CL-030 TEC1 ROI frame rates by clock frequency and number of taps for Mono8

Resolution		Mono12 (2 Taps)			Mono12 (1 Tap)		
Width	Height	25 MHz	55 MHz	85 MHz	25 MHz	55 MHz	85 MHz
656	520	120	135	135	66	135	135
640	480	132	146	146	73	146	146
320	240	273	273	273	265	273	273
160	120	484	484	484	484	484	484
656	264	231	251	251	128	251	251
656	8	1718	1718	1718	1718	1718	1718
8	520	135	135	135	135	135	135
8	8	1718	1718	1718	1718	1718	1718

Table 132: Goldeye CL-030 TEC1 ROI frame rates by clock frequency and number of taps for Mono12

## Goldeye CL-032 TEC1

### Imaging and performance

Parameter	Values
Sensor	InGaAs, progressive scan, electronic full frame shutter
Sensor type	FPA
Spectral range	900 nm to 1700 nm
Resolution (H × V)	636 × 508
Pixel size	25 μm × 25 μm
Sensor size (effective)	15.9 mm × 12.7 mm
Dark current (at +20 °C FPA temperature)	380 ke <sup>-</sup> /s
Temporal dark noise (Gain0)	400 e <sup>-</sup>
Temporal dark noise (Gain1)	170 e <sup>-</sup>
Saturation capacity (Gain0)	1.9 Me <sup>-</sup>
Saturation capacity (Gain1)	39 ke <sup>-</sup>
Dynamic range (Gain0)	73 dB
Dynamic range (Gain1)	47 dB
Pixel operability	>99.5%
Exposure time	6 μs to 200 ms <sup>1</sup>
Maximum frame rate at full resolution	100 fps
Temperature control	Single-stage thermo-electric cooling (TEC1)
Analog gain factor	1 (Gain0), 50 (Gain1)
A/D converter	14-bit
Image buffer size	256 MB
Stream hold capacity	397 frames at full resolution
<sup>1</sup> Maximum exposure value given is valid for Gain0 and sensor temperature of +20 °C. Even longer exposures can be set, but the image quality may deteriorate.	

Table 133: Goldeye CL-032 TEC1 imaging and performance

## Output

Parameter	Values
Digital interface	Camera Link Base, up to 2 taps, 40 MHz, SDR-26 connector, Serial Control Channel
Bit depth	8-bit to 14-bit
Pixel formats	<ul style="list-style-type: none"> <li>Tap geometry 1X 1Y: Mono8, Mono12, Mono14</li> <li>Tap geometry 1X2 1Y: Mono8, Mono12</li> </ul>

Table 134: Goldeye CL-032 TEC1 output

## GPIOs

Parameter	Values
Opto-isolated I/Os	1 input, 2 outputs
RS232	up to 115,200 bits per second, 8N1 (adjustable)
LVTTL I/Os	1 input, 1 output
LVDS inputs	CC1- CC4

Table 135: Goldeye CL-032 TEC1 GPIOs

## Mechanics

Parameter	Values
Body dimensions (L × W × H) without lens adapter	78 mm × 55 mm × 55 mm
Lens mounts	C-Mount, F-Mount, M42-Mount
Mass, body only, without adapter	320 g
Mass, with C-Mount adapter	340 g
Mass, with F-Mount adapter	400 g
Mass, with M42-Mount adapter	360 g

Table 136: Goldeye CL-032 TEC1 mechanics

## Operating conditions

Parameter	Values
Operating temperature	-20 °C to +55 °C (housing)
Storage temperature	-30 °C to +70 °C (ambient)
Sensor cooling temperature, setpoints	<ul style="list-style-type: none"> <li>+20 °C (default and calibrated)</li> <li>+5 °C, +35 °C, +50 °C (uncalibrated)</li> <li>User-configurable</li> </ul>
Relative humidity	10% to 95%, non-condensing
Power requirements (DC)	10.8 V to 30.0 V
Maximum power consumption	10 W (12 VDC)
Typical power consumption without cooling	4.5 W (12 VDC)

Table 137: Goldeye CL-032 TEC1 operating conditions

## Absolute QE

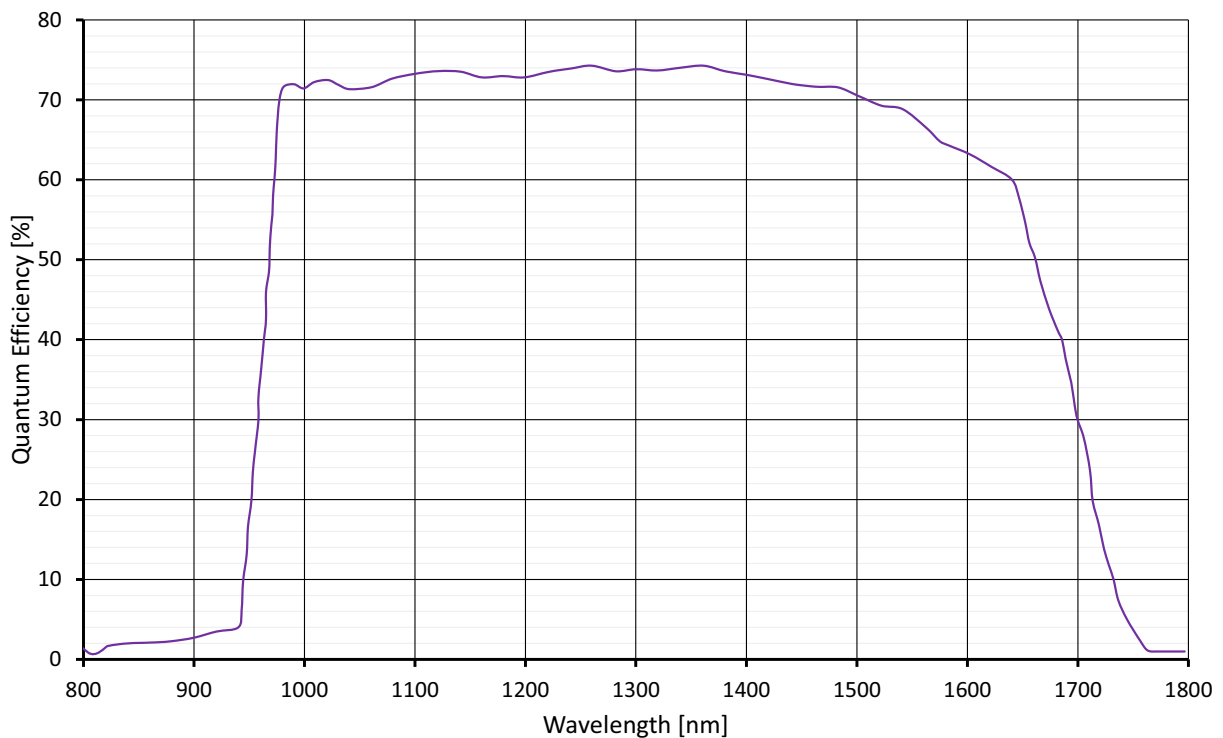

Figure 22: Goldeye CL-032 TEC1 absolute QE

## Resolution and ROI frame rates

The maximum frame rate for Goldeye CL-032 TEC1 is determined by the ROI size. Calculate the maximum frame rate using the following formulas.

$$\text{SensorFrameRate} = \frac{10,000,000}{\left[ (V + 4) \times \left( \frac{H}{4} + 32 \right) \right] + 131}$$

H	ROI: horizontal resolution (width). The formula is valid if $H \geq 128$ . For H always use the value rounded up to the next multiple of 16.
V	ROI: vertical resolution (height). The formula is valid if $V \geq 8$ . For V always use the value rounded up to the next multiple of 4.

When using the formula, please consider the following:

- Round the denominator down to the next full  $\mu\text{s}$ .
- Minimum ROI width is 8 pixels, minimum ROI height is 4 pixels.
- The formula generally outputs very exact values, however when the ROI approaches its minimum size, the accuracy decreases by some degree.
- Computational limitations of the host and image capture software may prevent the camera from achieving maximum frame rates.

$$\text{CameraLinkFrameRate} = \frac{\text{ClFrequency}}{\left[ \max((3 \times H + 32), A) + \left( \frac{H}{\text{Taps}} + B \right) (V - 1) + \left( \frac{H}{\text{Taps}} \right) + C + D \right]}$$

$$\text{FrameRate} = \min(\text{SensorFrameRate}, \text{CameraLinkFrameRate})$$

A	ClMinFValToLValDelay
B	ClLValToLValDelay
C	ClLValToFValDelay
D	ClMinFValToFValDelay

*Formula 20: Maximum frame rate for Goldeye CL-032 TEC1*

### ROI frame rates with different setups

Examples for maximum frame rates with Goldeye CL-032 TEC1 for common resolutions, are listed in the following table.

Resolution		Mono8, Mono12 (2 Taps)		Mono14 (1Tap)	
Width	Height	25 MHz	40 MHz	25 MHz	40 MHz
636	508	100	100	73	100
636	480	107	107	77	107
320	240	351	351	292	351
160	120	1047	1047	1047	1047
128	32	3507	3507	3507	3507
128	8	8264	8264	8264	8264

*Table 138: Goldeye CL-032 TEC1 ROI frame rates by pixel format, clock frequency, and number of taps*

## Goldeye CL-032 Cool TEC2

### Imaging and performance

Parameter	Values
Sensor	InGaAs, progressive scan, electronic full frame shutter
Sensor type	FPA
Spectral range	900 nm to 1700 nm
Resolution (H × V)	636 × 508
Pixel size	25 μm × 25 μm
Sensor size (effective)	15.9 mm × 12.7 mm
Dark current (at -20 °C FPA temperature)	30 ke <sup>-</sup> /s
Temporal dark noise (Gain0)	400 e <sup>-</sup>
Temporal dark noise (Gain1)	170 e <sup>-</sup>
Saturation capacity (Gain0)	1.9 Me <sup>-</sup>
Saturation capacity (Gain1)	39 ke <sup>-</sup>
Dynamic range (Gain0)	73 dB
Dynamic range (Gain1)	47 dB
Pixel operability	>99.5%
Exposure time	6 μs to 1250 ms <sup>1</sup>
Maximum frame rate at full resolution	100 fps
Temperature control	Dual-stage thermo-electric cooling (TEC2)
Analog gain factor	1 (Gain0), 50 (Gain1)
A/D converter	14-bit
Image buffer size	256 MB
Stream hold capacity	397 frames at full resolution
<sup>1</sup> Maximum exposure value given is valid for Gain0 and sensor temperature of -20 °C. Even longer exposures can be set, but the image quality may deteriorate.	

Table 139: Goldeye CL-032 Cool TEC2 imaging and performance



## Output

Parameter	Values
Digital interface	Camera Link Base, up to 2 taps, 40 MHz, SDR-26 connector, Serial Control Channel
Bit depth	8-bit to 14-bit
Pixel formats	<ul style="list-style-type: none"> <li>Tap geometry 1X 1Y: Mono8, Mono12, Mono14</li> <li>Tap geometry 1X2 1Y: Mono8, Mono12</li> </ul>

Table 140: Goldeye CL-032 Cool TEC2 output

## GPIOs

Parameter	Values
Opto-isolated I/Os	1 input, 2 outputs
RS232	up to 115,200 bits per second, 8N1 (adjustable)
LVTTL I/Os	1 input, 1 output
LVDS inputs	CC1- CC4

Table 141: Goldeye CL-032 Cool TEC2 GPIOs

## Mechanics

Parameter	Values
Body dimensions (L × W × H) without lens adapter	90 mm × 80 mm × 80 mm
Lens mounts	<ul style="list-style-type: none"> <li>C-Mount</li> <li>F-Mount and M42-Mount available on request</li> </ul>
Mass, body only, without adapter	760 g
Mass, with C-Mount adapter	780 g
Mass, with F-Mount adapter	840 g
Mass, with M42-Mount adapter	800 g

Table 142: Goldeye CL-032 Cool TEC2 mechanics

## Operating conditions

Parameter	Values
Operating temperature	-20 °C to +55 °C (housing)
Storage temperature	-30 °C to +70 °C (ambient)
Sensor cooling temperature, setpoints	<ul style="list-style-type: none"> <li>-20 °C (default and calibrated)</li> <li>-5 °C, +10 °C (uncalibrated)</li> <li>User-configurable</li> </ul>
Relative humidity	10% to 95%, non-condensing
Power requirements	10.8 V to 10.8 VDC
Maximum power consumption	19 W (12 VDC)
Typical power consumption without cooling	5.5 W (12 VDC)

Table 143: Goldeye CL-032 Cool TEC2 operating conditions

## Absolute QE



Figure 23: Goldeye CL-032 Cool TEC2 absolute QE

## Resolution and ROI frame rates

The maximum frame rate for Goldeye CL-032 Cool TEC2 is determined by the ROI size. Calculate the maximum frame rate using the following formulas.

$$\text{SensorFrameRate} = \frac{10,000,000}{\left[ (V + 4) \times \left( \frac{H}{4} + 32 \right) \right] + 131}$$

H	ROI: horizontal resolution (width). The formula is valid if $H \geq 128$ . For H always use the value rounded up to the next multiple of 16.
V	ROI: vertical resolution (height). The formula is valid if $V \geq 8$ . For V always use the value rounded up to the next multiple of 4.

When using the formula, please consider the following:

- Round the denominator down to the next full  $\mu\text{s}$ .
- Minimum ROI width is 8 pixels, minimum ROI height is 4 pixels.
- The formula generally outputs very exact values, however when the ROI approaches its minimum size, the accuracy decreases by some degree.
- Computational limitations of the host and image capture software may prevent the camera from achieving maximum frame rates.

$$\text{CameraLinkFrameRate} = \frac{\text{ClFrequency}}{\left[ \max((3 \times H + 32), A) + \left( \frac{H}{\text{Taps}} + B \right) (V - 1) + \left( \frac{H}{\text{Taps}} \right) + C + D \right]}$$

$$\text{FrameRate} = \min(\text{SensorFrameRate}, \text{CameraLinkFrameRate})$$

A	CIMinFValToLValDelay
B	CLLValToLValDelay
C	CLLValToFValDelay
D	CIMinFValToFValDelay

*Formula 21: Maximum frame rate for Goldeye CL-032 Cool TEC2*

### ROI frame rates with different setups

Examples for maximum frame rates with Goldeye CL-032 Cool TEC2 for common resolutions are listed in the following table.

Resolution		Remarks	Maximum frame rate [fps]
Width	Height		
636	508	Sensor full resolution	100
636	480	Approx. matches VGA format	107
320	240	QVGA	351
160	120	QQVGA	1047
≤ 128	≤ 8	For all resolutions smaller than this, the frame rate remains the same.	11123

*Table 144: Goldeye CL-032 Cool TEC2 ROI frame rates by pixel format, clock frequency, and number of taps*

## Goldeye CL-033 TEC1

### Imaging and performance

Parameter	Values
Sensor	InGaAs, progressive scan, electronic full frame shutter
Sensor type	FPA
Spectral range	900 nm to 1700 nm
Resolution (H × V)	640 × 512
Pixel size	15 μm × 15 μm
Sensor size (effective)	9.6 mm × 7.68 mm
Dark current	110 ke <sup>-</sup> /s <sup>1</sup>
Temporal dark noise (Gain0)	390 e <sup>-</sup> <sup>1, 2</sup>
Temporal dark noise (Gain1)	53 e <sup>-</sup> <sup>1, 2</sup>
Temporal dark noise (Gain2)	32 e <sup>-</sup> <sup>1, 2</sup>
Saturation capacity (Gain0)	1.2 Me <sup>-</sup> <sup>1, 2</sup>
Saturation capacity (Gain1)	84.8 ke <sup>-</sup> <sup>1, 2</sup>
Saturation capacity (Gain2)	25 ke <sup>-</sup> <sup>1, 2</sup>
Dynamic range (Gain0)	69 dB <sup>1, 2</sup>
Dynamic range (Gain1)	64 dB <sup>1, 2</sup>
Dynamic range (Gain2)	59 dB <sup>1, 2</sup>
Pixel operability	>99.5%
Maximum frame rate at full resolution	301 fps (8-bit and 12-bit pixel format)
Exposure time	1 μs to 200 ms <sup>3</sup>
Temperature control	Single-stage thermo-electric cooling (TEC1)
Analog gain factor	1 (Gain0), 14 (Gain1), 45 (Gain2)
A/D converter	14-bit
Image buffer size	256 MB
Stream hold capacity	392 frames at full resolution
<sup>1</sup> Typical values that are determined similar to EMVA 1288 under 1200 nm LED illumination. Given values are mean values of multiple different measurements at +20 °C FPA temperature, if not stated otherwise.	
<sup>2</sup> Measured with CDS delay of 12 μs.	
<sup>3</sup> Maximum exposure value given is valid for Gain0 and sensor temperature of +20 °C. Even longer exposures can be set, but the image quality may deteriorate.	

Table 145: Goldeye CL-033 TEC1 imaging and performance

## Output

Parameter	Values
Digital interface	Camera Link Base, up to 2 taps, 85 MHz, SDR-26 connector, Serial Control Channel
Bit depth	8-bit to 14-bit
Pixel formats	<ul style="list-style-type: none"> <li>Tap geometry 1X 1Y: Mono8, Mono12, Mono14</li> <li>Tap geometry 1X2 1Y: Mono8, Mono12</li> </ul>

Table 146: Goldeye CL-033 TEC1 output

## GPIOs

Parameter	Values
Opto-isolated I/Os	1 input, 2 outputs
RS232	up to 115,200 bits per second, 8N1 (adjustable)
LVTTL I/Os	1 input, 1 output
LVDS inputs	CC1- CC4

Table 147: Goldeye CL-033 TEC1 GPIOs

## Mechanics

Parameter	Values
Body dimensions (L × W × H) without lens adapter	78 mm × 55 mm × 55 mm
Lens mount	C-Mount, F-Mount, M42-Mount available
Mass, body only, without adapter	330 g
Mass, with C-Mount adapter	350 g
Mass, with F-Mount adapter	400 g
Mass, with M42-Mount adapter	370 g

Table 148: Goldeye CL-033 TEC1 mechanics

## Operating conditions

Parameter	Values
Operating temperature	-20 °C to +55 °C (housing)
Storage temperature	-30 °C to +70 °C (ambient)
Sensor cooling temperature, setpoints	<ul style="list-style-type: none"> <li>+20 °C (default and calibrated)</li> <li>+5 °C, +35 °C, +50 °C (uncalibrated)</li> <li>User-configurable</li> </ul>
Relative humidity	10% to 95%, non-condensing
Power requirements	10.8 VDC to 30.0 VDC
Maximum power consumption	11.8 W (12 VDC)
Typical power consumption without cooling	6.3 W (12 VDC)

Table 149: Goldeye CL-033 TEC1 operating conditions

## Absolute QE

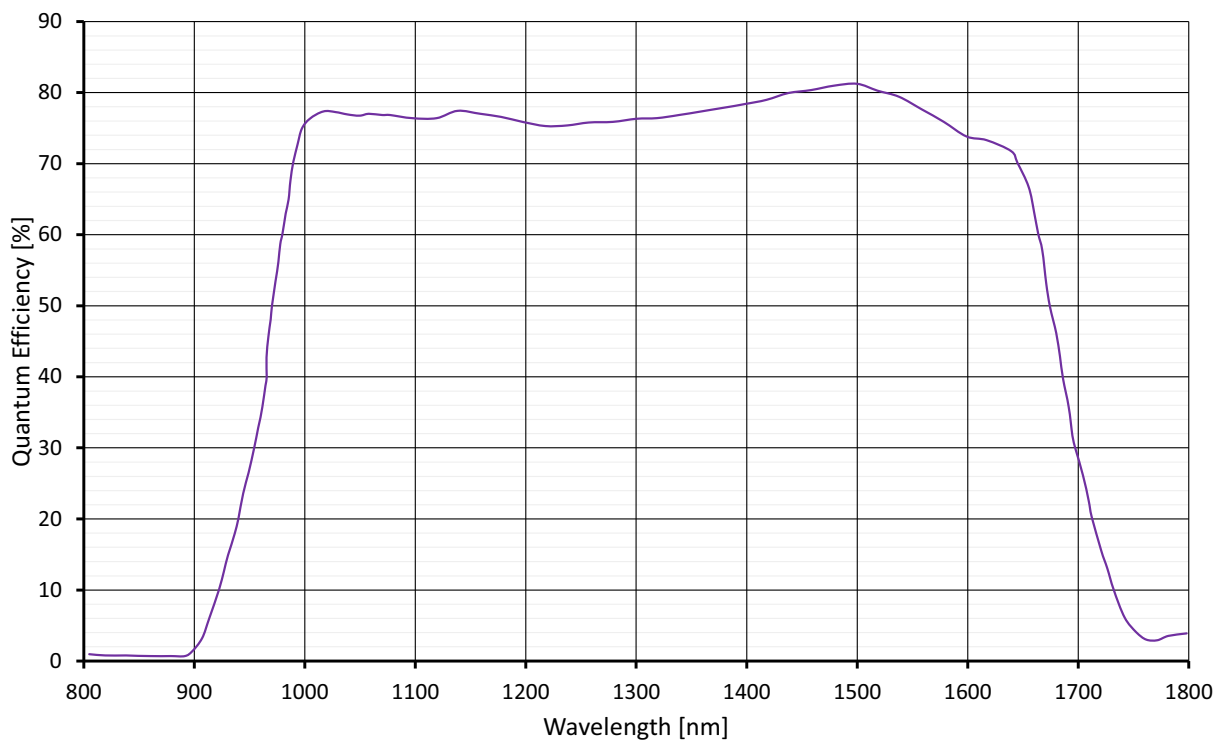

Figure 24: Goldeye CL-033 TEC1 absolute QE

## Resolution and ROI frame rate

The maximum frame rate for Goldeye CL-033 TEC1 is determined by the ROI size. Calculate the maximum frame rate using the following formulas.

$$\text{SensorFrameRate} = \frac{18,000,000}{\left[ (V + 1) \times \left( \frac{H}{8} + 36 \right) \right] + 254}$$

H	ROI: horizontal resolution (width). The formula is valid if $H \geq 128$ . For H always use the value rounded up to the next multiple of 32.
V	ROI: vertical resolution (height). The formula is valid if $V \geq 8$ . For V always use the value rounded up to the next multiple of 4.

When using the formula, please consider the following:

- Round the denominator up or down to the next full  $\mu\text{s}$ .
- Minimum ROI width is 8 pixels, minimum ROI height is 4 pixels.
- The formula generally outputs very exact values, however when the ROI approaches its minimum size, the accuracy decreases by some degree.
- Computational limitations of the host and image capture software may prevent the camera from achieving maximum frame rates.

$$\text{CameraLinkFrameRate} = \frac{\text{ClFrequency}}{\left[ \max((3 \times H + 32), A) + \left( \frac{H}{\text{Taps}} + B \right) (V - 1) + \left( \frac{H}{\text{Taps}} \right) + C + D \right]}$$

$$\text{FrameRate} = \min(\text{SensorFrameRate}, \text{CameraLinkFrameRate})$$

A	CIMinFValToLValDelay
B	CLLValToLValDelay
C	CLLValToFValDelay
D	CIMinFValToFValDelay

*Formula 22: Maximum frame rate for Goldeye CL-033 TEC1*



### ROI frame rates with different setups

Examples for maximum frame rates with Goldeye CL-033 TEC1 for common resolutions are listed in the following table.

Resolution		Mono8, Mono12 (2 Taps)			Mono14 (1Tap)		
Width	Height	25 MHz	55 MHz	85 MHz	25 MHz	55 MHz	85 MHz
640	512	125	276	301	68	151	234
640	480	134	295	321	73	161	250
320	256	428	251	909	251	553	855
320	240	456	268	968	268	590	912
160	120	1404	912	2557	912	2004	2557
128	32	5524	3802	9174	3802	8333	9174
128	8	17241	12658	25000	12658	25000	25000

*Table 150: Goldeye CL-033 TEC1 ROI frame rates by pixel format, clock frequency, and number of taps*

## Goldeye CL-033 TECless

### Imaging and performance

Parameter	Values
Sensor	InGaAs, progressive scan, electronic full frame shutter
Sensor type	FPA
Spectral range	900 nm to 1700 nm
Resolution (H × V)	640 × 512
Pixel size	15 μm × 15 μm
Sensor size (effective)	9.6 mm × 7.68 mm
Dark current (at +45 °C FPA temperature)	430 ke <sup>-</sup> /s <sup>1</sup>
Temporal dark noise (Gain0)	390 e <sup>-</sup> <sup>1, 2</sup>
Temporal dark noise (Gain1)	53 e <sup>-</sup> <sup>1, 2</sup>
Temporal dark noise (Gain2)	32 e <sup>-</sup> <sup>1, 2</sup>
Saturation capacity (Gain0)	1.2 Me <sup>-</sup> <sup>1, 2</sup>
Saturation capacity (Gain1)	84.8 ke <sup>-</sup> <sup>1, 2</sup>
Saturation capacity (Gain2)	25 ke <sup>-</sup> <sup>1, 2</sup>
Dynamic range (Gain0)	69 dB <sup>1, 2</sup>
Dynamic range (Gain1)	64 dB <sup>1, 2</sup>
Dynamic range (Gain2)	59 dB <sup>1, 2</sup>
Pixel operability	>99.5%
Maximum frame rate at full resolution	301 fps (8-bit and 12-bit pixel format)
Exposure time	1 μs to 200 ms <sup>3</sup>
Temperature control	Without thermo-electric cooling (TECless)
Analog gain factor	1 (Gain0), 14 (Gain1), 45 (Gain2)
A/D converter	14-bit
Image buffer size	256 MB
Stream hold capacity	392 frames at full resolution
<sup>1</sup> Typical values that are determined similar to EMVA 1288 under 1200 nm LED illumination. Given values are mean values of multiple different measurements at +45 °C FPA temperature, if not stated otherwise.	
<sup>2</sup> Measured with CDS delay of 12 μs.	
<sup>3</sup> Maximum exposure value given is valid for Gain0 and sensor temperature of +45 °C. Even longer exposures can be set, but the image quality may deteriorate.	

Table 151: Goldeye CL-033 TECless imaging and performance

## Output

Parameter	Values
Digital interface	Camera Link Base, up to 2 taps, 85 MHz, SDR-26 connector, Serial Control Channel
Bit depth	8-bit to 14-bit
Pixel formats	<ul style="list-style-type: none"> <li>Tap geometry 1X 1Y: Mono8, Mono12, Mono14</li> <li>Tap geometry 1X2 1Y: Mono8, Mono12</li> </ul>

Table 152: Goldeye CL-033 TECless output

## GPIO

Parameter	Values
Opto-isolated I/Os	1 input, 2 outputs
RS232	up to 115,200 bits per second, 8N1 (adjustable)
LVTTL I/Os	1 input, 1 output
LVDS inputs	CC1- CC4

Table 153: Goldeye CL-033 TECless GPIOs

## Mechanics

Parameter	Values
Body dimensions (L × W × H) without lens adapter	78 mm × 55 mm × 55 mm
Lens mounts	<ul style="list-style-type: none"> <li>C-Mount</li> <li>F-Mount and M42-Mount available on request</li> </ul>
Mass, body only, without adapter	300 g
Mass, with C-Mount adapter	320 g
Mass, with F-Mount adapter	370 g
Mass, with M42-Mount adapter	340 g

Table 154: Goldeye CL-033 TECless mechanics

## Operating conditions

Parameter	Values
Operating temperature	-20 °C to +55 °C (housing)
Storage temperature	-30 °C to +70 °C (ambient)
Sensor cooling temperature, setpoints	Not applicable to TECless models.
Relative humidity	10% to 95%, non-condensing
Power requirements	10.8 VDC to 30.0 VDC
Maximum power consumption	6.0 W (12 VDC)
Typical power consumption	6.0 W (12 VDC)

Table 155: Goldeye CL-033 TECless operating conditions

## Absolute QE

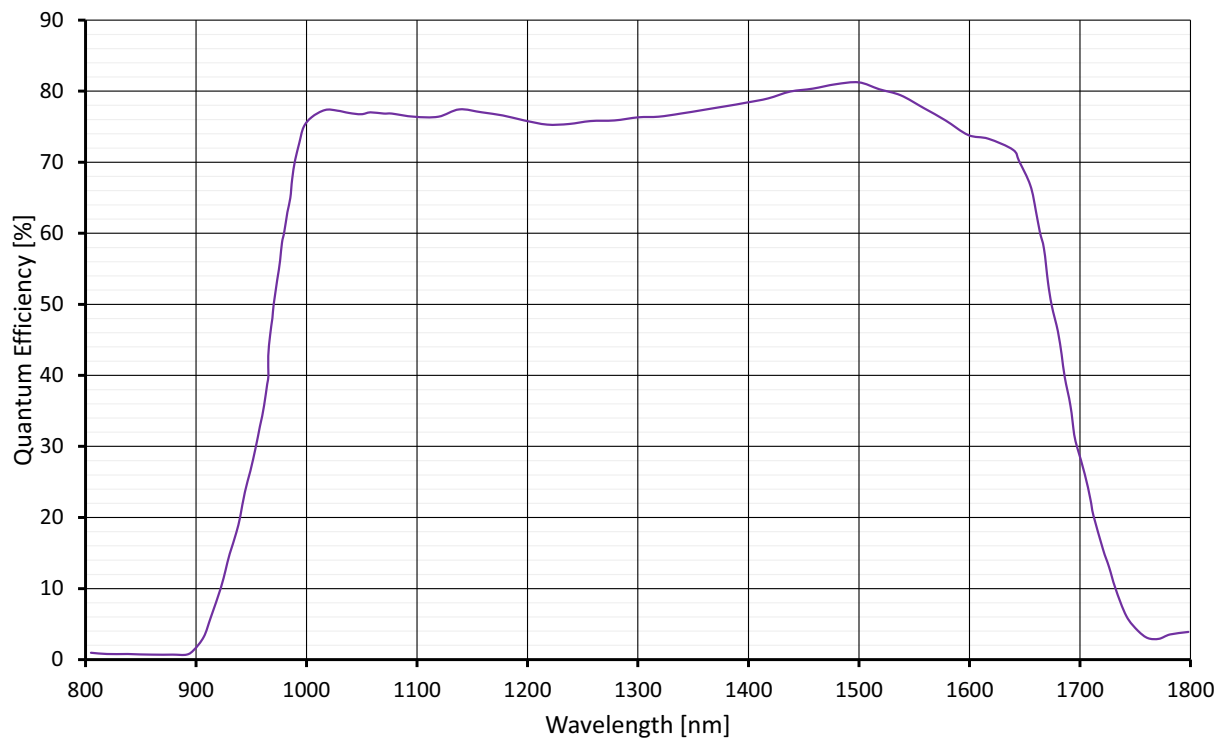

Figure 25: Goldeye CL-033 TECless absolute QE

## Resolution and ROI frame rate

The maximum frame rate for Goldeye CL-033 TECless is determined by the ROI size. Calculate the maximum frame rate using the following formulas.

$$\text{SensorFrameRate} = \frac{18,000,000}{\left[ (V + 1) \times \left( \frac{H}{8} + 36 \right) \right] + 254}$$

H	ROI: horizontal resolution (width). The formula is valid if $H \geq 128$ . For H always use the value rounded up to the next multiple of 32.
V	ROI: vertical resolution (height). The formula is valid if $V \geq 8$ . For V always use the value rounded up to the next multiple of 4.

When using the formula, please consider the following:

- Round the denominator up or down to the next full  $\mu\text{s}$ .
- Minimum ROI width is 8 pixels, minimum ROI height is 4 pixels.
- The formula generally outputs very exact values, however when the ROI approaches its minimum size, the accuracy decreases by some degree.
- Computational limitations of the host and image capture software may prevent the camera from achieving maximum frame rates.

$$\text{CameraLinkFrameRate} = \frac{\text{ClFrequency}}{\left[ \max((3 \times H + 32), A) + \left( \frac{H}{\text{Taps}} + B \right) (V - 1) + \left( \frac{H}{\text{Taps}} \right) + C + D \right]}$$

$$\text{FrameRate} = \min(\text{SensorFrameRate}, \text{CameraLinkFrameRate})$$

A	CIMinFValToLValDelay
B	CLLValToLValDelay
C	CLLValToFValDelay
D	CIMinFValToFValDelay

*Formula 23: Maximum frame rate for Goldeye CL-033 TECless*

### ROI frame rates with different setups

Examples for maximum frame rates with Goldeye CL-033 TECless for common resolutions are listed in the following table.

Resolution		Mono8, Mono12 (2 Taps)			Mono14 (1Tap)		
Width	Height	25 MHz	55 MHz	85 MHz	25 MHz	55 MHz	85 MHz
640	512	125	276	301	68	151	234
640	480	134	295	321	73	161	250
320	256	428	251	909	251	553	855
320	240	456	268	968	268	590	912
160	120	1404	912	2557	912	2004	2557
128	32	5524	3802	9174	3802	8333	9174
128	8	17241	12658	25000	12658	25000	25000

*Table 156: Goldeye CL-033 TECless ROI frame rates by pixel format, clock frequency, and number of taps*

## Goldeye CL-034 TEC1

### Imaging and performance

Parameter	Values
Sensor	InGaAs, progressive scan, electronic full frame shutter
Sensor type	FPA
Spectral range	900 nm to 1700 nm
Resolution (H × V)	636 × 508
Pixel size	15 μm × 15 μm
Sensor size (effective)	9.54 mm × 7.62 mm
Dark current	49 ke <sup>-</sup> /s <sup>1</sup>
Temporal dark noise (Gain0)	390 e <sup>-</sup> <sup>1, 2</sup>
Temporal dark noise (Gain1)	53 e <sup>-</sup> <sup>1, 2</sup>
Temporal dark noise (Gain2)	32 e <sup>-</sup> <sup>1, 2</sup>
Saturation capacity (Gain0)	1.2 Me <sup>-</sup> <sup>1, 2</sup>
Saturation capacity (Gain1)	84.8 ke <sup>-</sup> <sup>1, 2</sup>
Saturation capacity (Gain2)	25 ke <sup>-</sup> <sup>1, 2</sup>
Dynamic range (Gain0)	69 dB <sup>1, 2</sup>
Dynamic range (Gain1)	64 dB <sup>1, 2</sup>
Dynamic range (Gain2)	59 dB <sup>1, 2</sup>
Pixel operability	>99.5%
Maximum frame rate at full resolution	303 fps (8-bit and 12-bit pixel format)
Exposure time	1 μs to 200 ms <sup>3</sup>
Temperature control	Single-stage thermo-electric cooling (TEC1)
Analog gain factor	1 (Gain0), 14 (Gain1), 45 (Gain2)
A/D converter	14-bit
Image buffer size	256 MB
Stream hold capacity	392 frames at full resolution
<sup>1</sup> Typical values that are determined similar to EMVA 1288 under 1200 nm LED illumination. Given values are mean values of multiple different measurements at +20 °C FPA temperature, if not stated otherwise.	
<sup>2</sup> Measured with CDS delay of 12 μs.	
<sup>3</sup> Maximum exposure value given is valid for Gain0 and sensor temperature of +20 °C. Even longer exposures can be set, but the image quality may deteriorate.	

Table 157: Goldeye CL-034 TEC1 imaging and performance

## Output

Parameter	Values
Digital interface	Camera Link Base, up to 2 taps, 85 MHz, SDR-26 connector, Serial Control Channel
Bit depth	8-bit to 16-bit
Pixel formats	<ul style="list-style-type: none"> <li>Tap geometry 1X 1Y: Mono8, Mono10, Mono12, Mono14, Mono16</li> <li>Tap geometry 1X2 1Y: Mono8, Mono10, Mono12</li> </ul>

Table 158: Goldeye CL-034 TEC1 output

## GPIOs

Parameter	Values
Opto-isolated I/Os	1 input, 2 outputs
RS232	up to 115,200 bits per second, 8N1 (adjustable)
LVTTTL I/Os	1 input, 1 output
LVDS inputs	CC1- CC4

Table 159: Goldeye CL-034 TEC1 GPIOs

## Mechanics

Parameter	Values
Body dimensions (L × W × H) without lens adapter	78 mm × 55 mm × 55 mm
Lens mounts	C-Mount, F-Mount, M42-Mount
Mass, body only, without adapter	330 g
Mass, with C-Mount adapter	350 g
Mass, with F-Mount adapter	400 g
Mass, with M42-Mount adapter	370 g

Table 160: Goldeye CL-034 TEC1 mechanics



## Operating conditions

Parameter	Values
Operating temperature	-20 °C to +55 °C (housing)
Storage temperature	-30 °C to +70 °C (ambient)
Sensor cooling temperature, setpoints	<ul style="list-style-type: none"> <li>+20 °C (default and calibrated)</li> <li>+5 °C, +35 °C, +50 °C (uncalibrated)</li> <li>User-configurable</li> </ul>
Relative humidity	10% to 95%, non-condensing
Power requirements (DC)	10.8 V to 30.0 V
Maximum power consumption	11.8 W (12 VDC)
Typical power consumption without cooling	6.3 W (12 VDC)

Table 161: Goldeye CL-034 TEC1 operating conditions

## Absolute QE

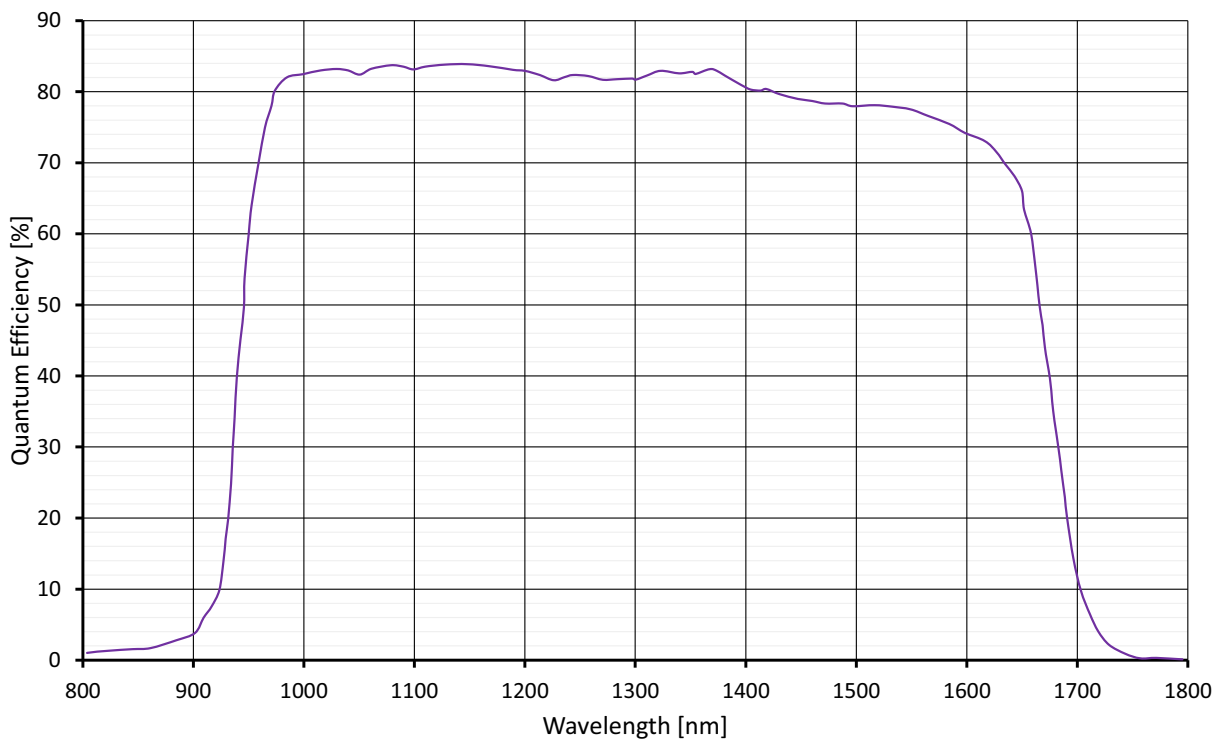

Figure 26: Goldeye CL-034 TEC1 absolute QE

## Resolution and ROI frame rate

The maximum frame rate for Goldeye CL-034 TEC1 is determined by the ROI size. Calculate the maximum frame rate using the following formulas.

$$\text{SensorFrameRate} = \frac{18,000,000}{\left[ (V + 1) \times \left( \frac{H}{8} + 36 \right) \right] + 254}$$

H	ROI: horizontal resolution (width). The formula is valid if $H \geq 128$ . For H always use the value rounded up to the next multiple of 32.
V	ROI: vertical resolution (height). The formula is valid if $V \geq 8$ . For V always use the value rounded up to the next multiple of 4.

When using the formula, please consider the following:

- Round the denominator up or down to the next full  $\mu\text{s}$ .
- Minimum ROI width is 8 pixels, minimum ROI height is 4 pixels.
- The formula generally outputs very exact values, however when the ROI approaches its minimum size, the accuracy decreases by some degree.
- Computational limitations of the host and image capture software may prevent the camera from achieving maximum frame rates.

$$\text{CameraLinkFrameRate} = \frac{\text{ClFrequency}}{\left[ \max((3 \times H + 32), A) + \left( \frac{H}{\text{Taps}} + B \right) (V - 1) + \left( \frac{H}{\text{Taps}} \right) + C + D \right]}$$

$$\text{FrameRate} = \min(\text{SensorFrameRate}, \text{CameraLinkFrameRate})$$

A	CIMinFValToLValDelay
B	CLLValToLValDelay
C	CLLValToFValDelay
D	CIMinFValToFValDelay

*Formula 24: Maximum frame rate for Goldeye CL-034 TEC1*

### ROI frame rates with different setups

Examples for maximum frame rates with Goldeye CL-034 TEC1 for common resolutions are listed in the following table.

Resolution		Mono8, Mono12 (2 Taps)			Mono14 (1Tap)		
Width	Height	25 MHz	55 MHz	85 MHz	25 MHz	55 MHz	85 MHz
636	508	125	276	303	68	151	234
636	480	134	295	321	73	161	250
320	256	428	251	909	251	553	855
320	240	456	268	968	268	590	912
160	120	1404	912	2557	912	2004	2557
128	32	5524	3802	9174	3802	8333	9174
128	8	17241	12658	25000	12658	25000	25000

*Table 162: Goldeye CL-034 TEC1 ROI frame rates by pixel format, clock frequency, and number of taps*

## Goldeye CL-034 TEC2

### Imaging and performance



#### Measurement values

Actual values for dark current and temporal dark noise partly depend on the ambient temperature of your application.

Parameter	Values
Sensor	InGaAs, progressive scan, electronic full frame shutter
Sensor type	FPA
Spectral range	900 nm to 1700 nm
Resolution (H × V)	636 × 508
Pixel size	15 μm × 15 μm
Sensor size (effective)	9.54 mm × 7.62 mm
Dark current	26 ke <sup>-</sup> /s <sup>1</sup>
Temporal dark noise (Gain0)	390 e <sup>-</sup> <sup>1,2</sup>
Temporal dark noise (Gain1)	53 e <sup>-</sup> <sup>1,2</sup>
Temporal dark noise (Gain2)	32 e <sup>-</sup> <sup>1,2</sup>
Saturation capacity (Gain0)	1.2 Me <sup>-</sup> <sup>1,2</sup>
Saturation capacity (Gain1)	84.8 ke <sup>-</sup> <sup>1,2</sup>
Saturation capacity (Gain2)	25 ke <sup>-</sup> <sup>1,2</sup>
Dynamic range (Gain0)	69 dB <sup>1,2</sup>
Dynamic range (Gain1)	64 dB <sup>1,2</sup>
Dynamic range (Gain2)	59 dB <sup>1,2</sup>
Pixel operability	>99.5%
Maximum frame rate at full resolution	303 fps (8-bit and 12-bit pixel format)
Exposure time	1 μs to 10 s <sup>3</sup>
Temperature control	Dual-stage thermo-electric cooling (TEC2)
Analog gain factor	1 (Gain0), 14 (Gain1), 45 (Gain2)

<sup>1</sup> Typical values that are determined similar to EMVA 1288 under 1200 nm LED illumination. Given values are mean values of multiple different measurements at -30 °C FPA temperature, if not stated otherwise.

<sup>2</sup> Measured with CDS delay of 12 μs.

<sup>3</sup> Maximum exposure value given is valid for Gain0 and sensor temperature of -30 °C. Even longer exposures can be set, but the image quality may deteriorate.

Table 163: Goldeye CL-034 TEC2 imaging and performance (sheet 1 of 2)

Parameter	Values
A/D converter	14-bit
Image buffer size	256 MB
Stream hold capacity	392 frames at full resolution
<sup>1</sup> Typical values that are determined similar to EMVA 1288 under 1200 nm LED illumination. Given values are mean values of multiple different measurements at -30 °C FPA temperature, if not stated otherwise.	
<sup>2</sup> Measured with CDS delay of 12 μs.	
<sup>3</sup> Maximum exposure value given is valid for Gain0 and sensor temperature of -30 °C. Even longer exposures can be set, but the image quality may deteriorate.	

Table 163: Goldeye CL-034 TEC2 imaging and performance (sheet 2 of 2)

## Output

Parameter	Values
Digital interface	Camera Link Base, up to 2 taps, 85 MHz, SDR-26 connector, Serial Control Channel
Bit depth	8-bit to 16-bit
Pixel formats	<ul style="list-style-type: none"> <li>Tap geometry 1X 1Y: Mono8, Mono10, Mono12, Mono14, Mono16</li> <li>Tap geometry 1X2 1Y: Mono8, Mono10, Mono12</li> </ul>

Table 164: Goldeye CL-034 TEC2 output

## GPIOs

Parameter	Values
Opto-isolated I/Os	1 input, 2 outputs
RS232	up to 115,200 bits per second, 8N1 (adjustable)
LVTTL I/Os	1 input, 1 output
LVDS inputs	CC1- CC4

Table 165: Goldeye CL-034 TEC2 GPIOs

## Mechanics

Parameter	Values
Body dimensions (L × W × H) without lens adapter	90 mm × 80 mm × 80 mm
Lens mount	C-Mount
Mass, including lens mount	740 g

Table 166: Goldeye CL-034 TEC2 mechanics

## Operating conditions

Parameter	Values
Operating temperature	-20 °C to +55 °C (housing)
Storage temperature	-30 °C to +70 °C (ambient)
Sensor cooling temperature, setpoints	<ul style="list-style-type: none"> <li>-30 °C (default and calibrated)</li> <li>-20 °C, -10 °C (calibrated)</li> <li>0 °C (uncalibrated)</li> <li>User-configurable</li> </ul>
Relative humidity	10% to 95%, non-condensing
Power requirements (DC)	10.8 V to 30.0 V
Maximum power consumption	21 W (12 VDC)
Typical power consumption without cooling	7 W (12 VDC)

Table 167: Goldeye CL-034 TEC2 operating conditions

## Absolute QE

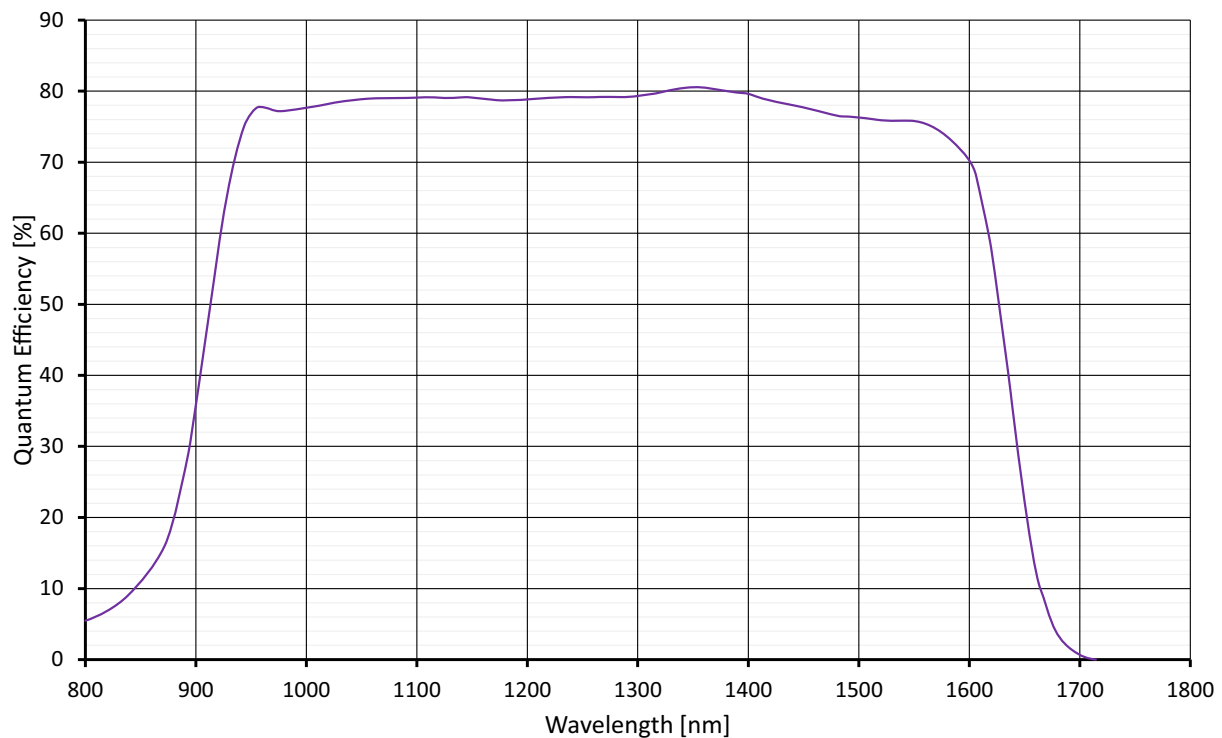

Figure 27: Goldeye CL-034 TEC2 absolute QE

## Resolution and ROI frame rate

The maximum frame rate for Goldeye CL-034 TEC2 is determined by the ROI size. Calculate the maximum frame rate using the following formulas.

$$\text{SensorFrameRate} = \frac{18,000,000}{\left[ (V + 1) \times \left( \frac{H}{8} + 36 \right) \right] + 254}$$

H	ROI: horizontal resolution (width). The formula is valid if $H \geq 128$ . For H always use the value rounded up to the next multiple of 32.
V	ROI: vertical resolution (height). The formula is valid if $V \geq 8$ . For V always use the value rounded up to the next multiple of 4.

When using the formula, please consider the following:

- Round the denominator up or down to the next full  $\mu\text{s}$ .
- Minimum ROI width is 8 pixels, minimum ROI height is 4 pixels.
- The formula generally outputs very exact values, however when the ROI approaches its minimum size, the accuracy decreases by some degree.
- Computational limitations of the host and image capture software may prevent the camera from achieving maximum frame rates.

$$\text{CameraLinkFrameRate} = \frac{\text{ClFrequency}}{\left[ \max((3 \times H + 32), A) + \left( \frac{H}{\text{Taps}} + B \right) (V - 1) + \left( \frac{H}{\text{Taps}} \right) + C + D \right]}$$

$$\text{FrameRate} = \min(\text{SensorFrameRate}, \text{CameraLinkFrameRate})$$

A	CIMinFValToLValDelay)
B	CLLValToLValDelay
C	CLLValToFValDelay
D	CIMinFValToFValDelay

*Formula 25: Maximum frame rate for Goldeye CL-034 TEC2*

### ROI frame rates with different setups

Examples for maximum frame rates with Goldeye CL-034 TEC2 for common resolutions are listed in the following table.

Resolution		Mono8, Mono12 (2 Taps)			Mono14 (1Tap)		
Width	Height	25 MHz	55 MHz	85 MHz	25 MHz	55 MHz	85 MHz
636	508	125	276	303	68	151	234
636	480	134	295	321	73	161	250
320	256	428	251	909	251	553	855
320	240	456	268	968	268	590	912
160	120	1404	912	2557	912	2004	2557
128	32	5524	3802	9174	3802	8333	9174
128	8	17241	12658	25000	12658	25000	25000

*Table 168: Goldeye CL-034 TEC2 ROI frame rates by pixel format, clock frequency, and number of taps*



## Goldeye CL-034 XSWIR 1.9 TEC2

### Imaging and performance

Parameter	Values
Sensor	InGaAs, progressive scan, electronic full frame shutter
Sensor type	FPA
Spectral range	1100 nm to 1900 nm
Resolution (H × V)	636 × 508
Pixel size	15 μm × 15 μm
Sensor size (effective)	9.54 mm × 7.62 mm
Dark current	140 ke <sup>-</sup> /s <sup>1</sup>
Temporal dark noise (Gain0)	434 e <sup>-</sup> <sup>1,2</sup>
Temporal dark noise (Gain1)	40 e <sup>-</sup> <sup>1,2</sup>
Temporal dark noise (Gain2)	15 e <sup>-</sup> <sup>1,2</sup>
Saturation capacity (Gain0)	1.3 Me <sup>-</sup> <sup>1,2</sup>
Saturation capacity (Gain1)	66 ke <sup>-</sup> <sup>1,2</sup>
Saturation capacity (Gain2)	18 ke <sup>-</sup> <sup>1,2</sup>
Dynamic range (Gain0)	69 dB <sup>1,2</sup>
Dynamic range (Gain1)	64 dB <sup>1,2</sup>
Dynamic range (Gain2)	61 dB <sup>1,2</sup>
Pixel operability	>98.5% <sup>1,2</sup>
Maximum frame rate at full resolution	303 fps (8-bit and 12-bit pixel format)
Exposure time	1 μs to 20 ms <sup>3</sup>
Temperature control	Dual-stage thermo-electric cooling (TEC2)
Analog gain factor	1 (Gain0), 14 (Gain1), 45 (Gain2)
A/D converter	14-bit
Image buffer size	256 MB
Stream hold capacity	392 frames at full resolution

<sup>1</sup> Typical values that are determined similar to EMVA 1288 under 1200 nm LED illumination. Given values are mean values of multiple different measurements at -30 °C FPA temperature, if not stated otherwise.

<sup>2</sup> Measured with CDS delay of 12 μs.

<sup>3</sup> Maximum exposure value given is valid for Gain0 and sensor temperature of -30 °C. Even longer exposures can be set, but the image quality may deteriorate.

Table 169: Goldeye CL-034 XSWIR 1.9 TEC2 imaging and performance

## Output

Parameter	Values
Digital interface	Camera Link Base, up to 2 taps, 85 MHz, SDR-26 connector, Serial Control Channel
Bit depth	8-bit to 16-bit
Pixel formats	<ul style="list-style-type: none"> <li>Tap geometry 1X 1Y: Mono8, Mono10, Mono12, Mono14, Mono16</li> <li>Tap geometry 1X2 1Y: Mono8, Mono10, Mono12</li> </ul>

Table 170: Goldeye CL-034 XSWIR 1.9 TEC2 output

## GPIOs

Parameter	Values
Opto-isolated I/Os	1 input, 2 outputs
RS232	up to 115,200 bits per second, 8N1 (adjustable)
LVTTTL I/Os	1 input, 1 output
LVDS inputs	CC1- CC4

Table 171: Goldeye CL-034 XSWIR 1.9 TEC2 GPIOs

## Mechanics

Parameter	Values
Body dimensions (L × W × H) without lens mount adapter	90 mm × 80 mm × 80 mm
Lens mount	C-Mount
Mass, including lens mount	740 g

Table 172: Goldeye CL-034 XSWIR 1.9 TEC2 mechanics

### Operating conditions

Parameter	Values
Operating temperature	-20 °C to +55 °C (housing)
Storage temperature	-30 °C to +70 °C (ambient)
Sensor cooling temperature, setpoints	<ul style="list-style-type: none"> <li>• -30 °C (default and calibrated)</li> <li>• -20 °C, -10 °C (calibrated)</li> <li>• 0 °C (uncalibrated)</li> <li>• User-configurable</li> </ul>
Relative humidity	10% to 95%, non-condensing
Power requirements (DC)	10.8 V to 30.0 V
Maximum power consumption	21 W (12 VDC)
Typical power consumption without cooling	7 W (12 VDC)

*Table 173: Goldeye CL-034 XSWIR 1.9 TEC2 operating conditions*

## Absolute QE



### Quantum efficiency for various sensor temperature values

The following curves relate to a sensor temperatures of -20 °C and -30 °C default, the sensitivity is slightly shifted to lower wave lengths, but the range is maintained. With increased sensor temperatures, the QE curve is slightly shifted to longer wavelengths, and for lower temperatures it is shifted to shorter wavelengths.

See the corresponding application note at [www.alliedvision.com/fileadmin/content/documents/products/cameras/Goldeye\\_2/appnote/Goldeye-G-CL\\_AppNote\\_Temperature-Influence-on-Image-Quality\\_en.pdf](http://www.alliedvision.com/fileadmin/content/documents/products/cameras/Goldeye_2/appnote/Goldeye-G-CL_AppNote_Temperature-Influence-on-Image-Quality_en.pdf).

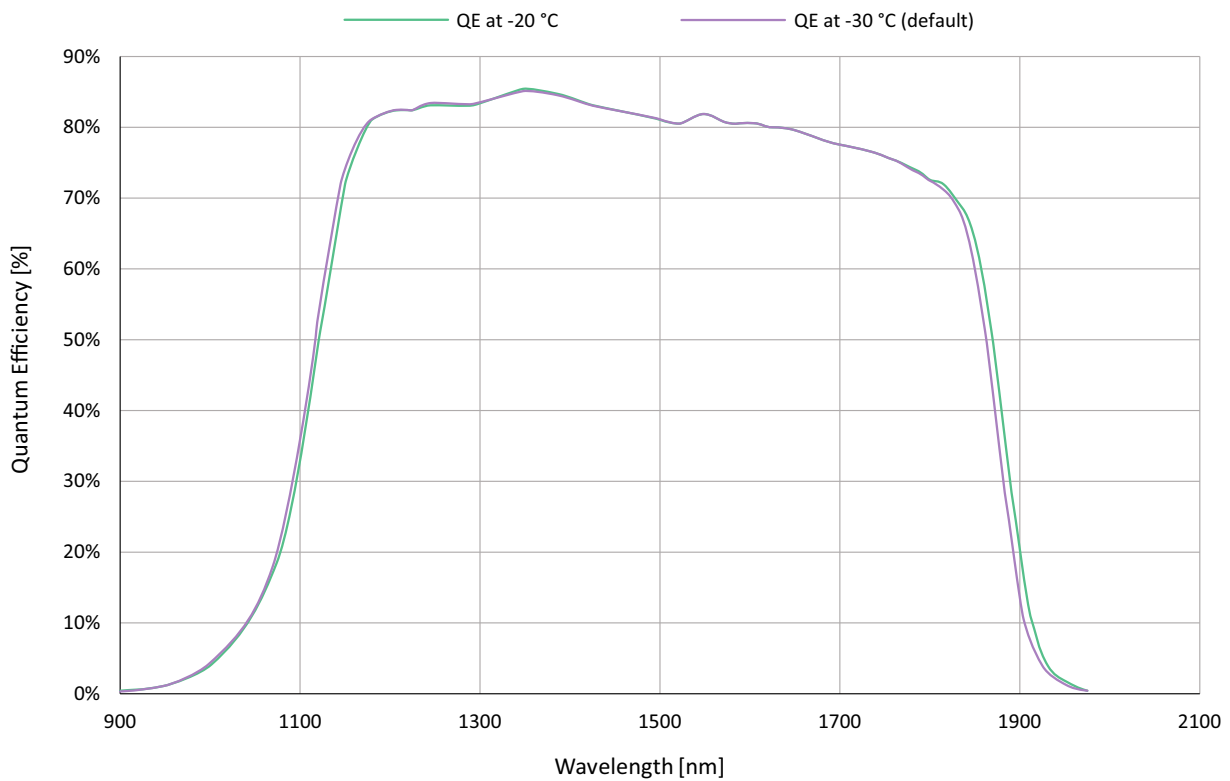

Figure 28: Goldeye CL-034 XSWIR 1.9 TEC2 absolute QE

## Resolution and ROI frame rate



### Values when using MultiRegions features

When the camera is operated using more than a single ROI, values in this section may not be reached.

The maximum frame rate for Goldeye CL-034 XSWIR 1.9 TEC2 is determined by the ROI size. Calculate the maximum frame rate using the following formulas.

$$\text{SensorFrameRate} = \frac{18,000,000}{\left[ (V + 1) \times \left( \frac{H}{8} + 36 \right) \right] + 254}$$

H	ROI: horizontal resolution (width). The formula is valid if $H \geq 128$ . For H always use the value rounded up to the next multiple of 32.
V	ROI: vertical resolution (height). The formula is valid if $V \geq 8$ . For V always use the value rounded up to the next multiple of 4.

When using the formula, please consider the following:

- Round the denominator up or down to the next full  $\mu\text{s}$ .
- Minimum ROI width is 8 pixels, minimum ROI height is 4 pixels.
- The formula generally outputs very exact values, however when the ROI approaches its minimum size, the accuracy decreases by some degree.
- Computational limitations of the host and image capture software may prevent the camera from achieving maximum frame rates.

$$\text{CameraLinkFrameRate} = \frac{\text{CIFrequency}}{\left[ \max((3 \times H + 32), A) + \left( \frac{H}{\text{Taps}} + B \right) (V - 1) + \left( \frac{H}{\text{Taps}} \right) + C + D \right]}$$

$$\text{FrameRate} = \min(\text{SensorFrameRate}, \text{CameraLinkFrameRate})$$

A	CIMinFValToLValDelay)
B	CLLValToLValDelay
C	CLLValToFValDelay
D	CIMinFValToFValDelay

*Formula 26: Maximum frame rate for Goldeye CL-034 XSWIR 1.9 TEC2*

### ROI frame rates with different setups

Examples for maximum frame rates with Goldeye CL-034 XSWIR 1.9 TEC2 for common resolutions are listed in the following table.

Resolution		Mono8, Mono12 (2 Taps)			Mono14 (1Tap)		
Width	Height	25 MHz	55 MHz	85 MHz	25 MHz	55 MHz	85 MHz
636	508	125	276	303	68	151	234
636	480	134	295	321	73	161	250
320	256	428	251	909	251	553	855
320	240	456	268	968	268	590	912
160	120	1404	912	2557	912	2004	2557
128	32	5524	3802	9174	3802	8333	9174
128	8	17241	12658	25000	12658	25000	25000

*Table 174: Goldeye CL-034 XSWIR 1.9 TEC2 ROI frame rates by pixel format, clock frequency, and number of taps*

## Goldeye CL-034 XSWIR 2.2 TEC2

### Imaging and performance

Parameter	Values
Sensor	InGaAs, progressive scan, electronic full frame shutter
Sensor type	FPA
Spectral range	1200 nm to 2200 nm
Resolution (H × V)	636 × 508
Pixel size	15 μm × 15 μm
Sensor size (effective)	9.54 mm × 7.62 mm
Dark current	820 ke <sup>-</sup> /s <sup>1</sup>
Temporal dark noise (Gain0)	452 e <sup>-</sup> <sup>1,2</sup>
Temporal dark noise (Gain1)	134 e <sup>-</sup> <sup>1,2</sup>
Temporal dark noise (Gain2)	58 e <sup>-</sup> <sup>1,2</sup>
Saturation capacity (Gain0)	1.16 Me <sup>-</sup> <sup>1,2</sup>
Saturation capacity (Gain1)	73 ke <sup>-</sup> <sup>1,2</sup>
Saturation capacity (Gain2)	25 ke <sup>-</sup> <sup>1,2</sup>
Dynamic range (Gain0)	68 dB <sup>1,2</sup>
Dynamic range (Gain1)	54 dB <sup>1,2</sup>
Dynamic range (Gain2)	52 dB <sup>1,2</sup>
Pixel operability	>98.5% <sup>1,2</sup>
Maximum frame rate at full resolution	303 fps (8-bit and 12-bit pixel format)
Exposure time	1 μs to 10 ms <sup>3</sup>
Temperature control	Dual-stage thermo-electric cooling (TEC2)
Analog gain factor	1 (Gain0), 14 (Gain1), 45 (Gain2)
A/D converter	14-bit
Image buffer size	256 MB
Stream hold capacity	392 frames at full resolution

<sup>1</sup> Typical values that are determined similar to EMVA 1288 under 1485 nm LED illumination. Given values are mean values of multiple different measurements at -30 °C FPA temperature, if not stated otherwise.

<sup>2</sup> Measured with CDS delay of 12 μs.

<sup>3</sup> Maximum exposure value given is valid for Gain0 and sensor temperature of -30 °C. Even longer exposures can be set, but the image quality may deteriorate.

Table 175: Goldeye CL-034 XSWIR 2.2 TEC2 imaging and performance

## Output

Parameter	Values
Digital interface	Camera Link Base, up to 2 taps, 85 MHz, SDR-26 connector, Serial Control Channel
Bit depth	8-bit to 16-bit
Pixel formats	<ul style="list-style-type: none"> <li>Tap geometry 1X 1Y: Mono8, Mono10, Mono12, Mono14, Mono16</li> <li>Tap geometry 1X2 1Y: Mono8, Mono10, Mono12</li> </ul>

Table 176: Goldeye CL-034 XSWIR 2.2 TEC2 output

## GPIOs

Parameter	Values
Opto-isolated I/Os	1 input, 2 outputs
RS232	up to 115,200 bits per second, 8N1 (adjustable)
LVTTTL I/Os	1 input, 1 output
LVDS inputs	CC1- CC4

Table 177: Goldeye CL-034 XSWIR 2.2 TEC2 GPIOs

## Mechanics

Parameter	Values
Body dimensions (L × W × H) without lens mount adapter	90 mm × 80 mm × 80 mm
Lens mount	C-Mount
Mass, including lens mount	740 g

Table 178: Goldeye CL-034 XSWIR 2.2 TEC2 mechanics



### Operating conditions

Parameter	Values
Operating temperature	-20 °C to +55 °C (housing)
Storage temperature	-30 °C to +70 °C (ambient)
Sensor cooling temperature, setpoints	<ul style="list-style-type: none"> <li>• -30 °C (default and calibrated)</li> <li>• -20 °C, -10 °C (calibrated)</li> <li>• 0 °C (uncalibrated)</li> <li>• User-configurable</li> </ul>
Relative humidity	10% to 95%, non-condensing
Power requirements (DC)	10.8 V to 30.0 V
Maximum power consumption	21 W (12 VDC)
Typical power consumption without cooling	7 W (12 VDC)

*Table 179: Goldeye CL-034 XSWIR 2.2 TEC2 operating conditions*

## Absolute QE



### Quantum efficiency for various sensor temperature values

The following curves relate to a sensor temperatures of -20 °C and -30 °C default, the sensitivity is slightly shifted to lower wave lengths, but the range is maintained. With increased sensor temperatures, the QE curve is slightly shifted to longer wavelengths, and for lower temperatures it is shifted to shorter wavelengths.

See the corresponding application note at [www.alliedvision.com/fileadmin/content/documents/products/cameras/Goldeye\\_2/appnote/Goldeye-G-CL\\_AppNote\\_Temperature-Influence-on-Image-Quality\\_en.pdf](http://www.alliedvision.com/fileadmin/content/documents/products/cameras/Goldeye_2/appnote/Goldeye-G-CL_AppNote_Temperature-Influence-on-Image-Quality_en.pdf).

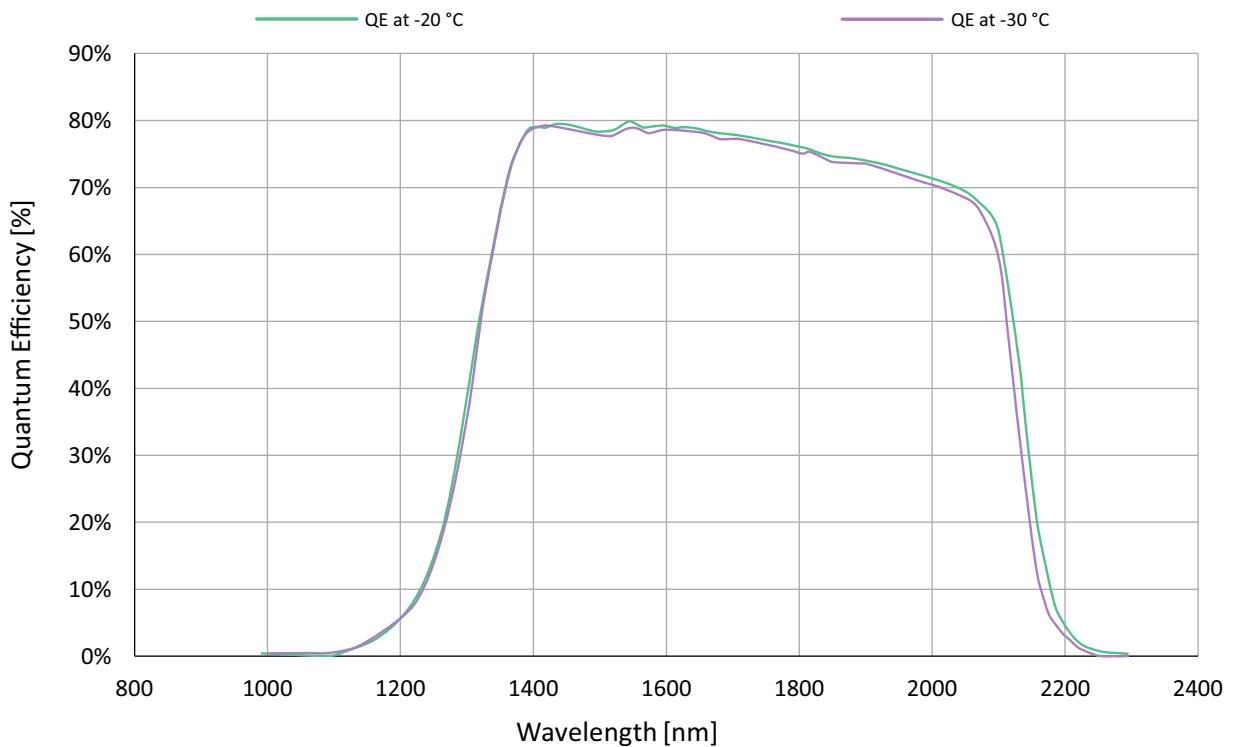

Figure 29: Goldeye CL-034 XSWIR 2.2 TEC2 absolute QE

## Resolution and ROI frame rate



### Values when using MultiRegions features

When the camera is operated using more than a single ROI, values in this section may not be reached.

The maximum frame rate for Goldeye CL-034 XSWIR 2.2 TEC2 is determined by the ROI size. Calculate the maximum frame rate using the following formulas.

$$\text{SensorFrameRate} = \frac{18,000,000}{\left[ (V + 1) \times \left( \frac{H}{8} + 36 \right) \right] + 254}$$

H	ROI: horizontal resolution (width). The formula is valid if $H \geq 128$ . For H always use the value rounded up to the next multiple of 32.
V	ROI: vertical resolution (height). The formula is valid if $V \geq 8$ . For V always use the value rounded up to the next multiple of 4.

When using the formula, please consider the following:

- Round the denominator up or down to the next full  $\mu\text{s}$ .
- Minimum ROI width is 8 pixels, minimum ROI height is 4 pixels.
- The formula generally outputs very exact values, however when the ROI approaches its minimum size, the accuracy decreases by some degree.
- Computational limitations of the host and image capture software may prevent the camera from achieving maximum frame rates.

$$\text{CameraLinkFrameRate} = \frac{\text{CIFrequency}}{\left[ \max((3 \times H + 32), A) + \left( \frac{H}{\text{Taps}} + B \right) (V - 1) + \left( \frac{H}{\text{Taps}} \right) + C + D \right]}$$

$$\text{FrameRate} = \min(\text{SensorFrameRate}, \text{CameraLinkFrameRate})$$

A	CIMinFValToLValDelay)
B	CLLValToLValDelay
C	CLLValToFValDelay
D	CIMinFValToFValDelay

*Formula 27: Maximum frame rate for Goldeye CL-034 XSWIR 2.2 TEC2*

### ROI frame rates with different setups

Examples for maximum frame rates with Goldeye CL-034 XSWIR 2.2 TEC2 for common resolutions are listed in the following table.

Resolution		Mono8, Mono12 (2 Taps)			Mono14 (1Tap)		
Width	Height	25 MHz	55 MHz	85 MHz	25 MHz	55 MHz	85 MHz
636	508	125	276	303	68	151	234
636	480	134	295	321	73	161	250
320	256	428	251	909	251	553	855
320	240	456	268	968	268	590	912
160	120	1404	912	2557	912	2004	2557
128	32	5524	3802	9174	3802	8333	9174
128	8	17241	12658	25000	12658	25000	25000

*Table 180: Goldeye CL-034 XSWIR 2.2 TEC2 ROI frame rates by pixel format, clock frequency, and number of taps*

## Goldeye CL-130 TEC1

### Imaging and performance

Parameter	Values
Sensor model	Sony IMX990 SenSWIR
Sensor type	InGaAs
Sensor format	Type 1/2 (8.2 mm diagonal)
Shutter type	Global shutter
Spectral range	400 nm to 1700 nm
Resolution (H × V)	1280 × 1024
Pixel size	5 μm × 5 μm
Sensor size (effective)	6.4 mm × 5.12 mm
Dark current (at +20 °C FPA temperature)	4.8 ke <sup>-</sup> /s
Temporal dark noise (0 dB)	250 e <sup>-</sup>
Temporal dark noise (18 dB)	210 e <sup>-</sup>
Saturation capacity (0 dB)	165 ke <sup>-</sup>
Saturation capacity (18 dB)	17.2 ke <sup>-</sup>
Dynamic range (0 dB)	56.4 dB
Dynamic range (18 dB)	38.2 dB
Pixel operability	>99.5%
Exposure time	18 μs to 200 ms <sup>1</sup> (Normal <sup>2</sup> )   3 μs to 7 μs (Ultrashort <sup>2</sup> )
Maximum frame rate at full resolution	94 fps
Temperature control	Single-stage thermo-electric cooling (TEC1)
Analog gain factor	1 (0 dB), 7.9 (18 dB)
A/D converter	12-bit
Image buffer size	256 MB
Stream hold capacity	95 frames at full resolution
<sup>1</sup> Maximum exposure value given is valid for 0 dB and sensor temperature of +20 °C. Even longer exposures can be set, but the image quality may deteriorate.	
<sup>2</sup> Values for ExposureRangeMode = <i>Normal</i> or <i>Ultrashort</i>	

Table 181: Goldeye CL-130 TEC1 imaging and performance

## Output

Parameter	Values
Digital interface	Camera Link Base, up to 2 taps, 40 MHz, SDR-26 connector, Serial Control Channel
Bit depth	8-bit to 12-bit
Pixel formats	<ul style="list-style-type: none"> <li>Tap geometry 1X 1Y: Mono8, Mono12</li> <li>Tap geometry 1X2 1Y: Mono8, Mono12</li> </ul>

Table 182: Goldeye CL-130 TEC1 output

## GPIOs

Parameter	Values
Opto-isolated I/Os	1 input, 2 outputs
RS232	up to 115,200 bits per second, 8N1 (adjustable)
LVTTL I/Os	1 input, 1 output
LVDS inputs	CC1- CC4

Table 183: Goldeye CL-130 TEC1 GPIOs

## Mechanics

Parameter	Values
Body dimensions (L × W × H) without lens mount adapter	78 mm × 55 mm × 55 mm
Lens mount	C-Mount
Mass, including lens mount	330 g

Table 184: Goldeye CL-130 TEC1 mechanics

## Operating conditions

Parameter	Values
Operating temperature	-20 °C to +55 °C (housing)
Storage temperature	-30 °C to +70 °C (ambient)
Temperature setpoints <sup>1</sup>	<ul style="list-style-type: none"> <li>+20 °C (default and calibrated)</li> <li>+5 °C, +35 °C, +50 °C (uncalibrated)</li> <li>User-configurable</li> </ul>
Relative humidity	10% to 95%, non-condensing
Power requirements (DC)	10.8 V to 30.0 V
Maximum power consumption	11.8 W (12 VDC)
Typical power consumption without cooling	5.4 W (12 VDC)

Table 185: Goldeye CL-130 TEC1 operating conditions

## Relative QE

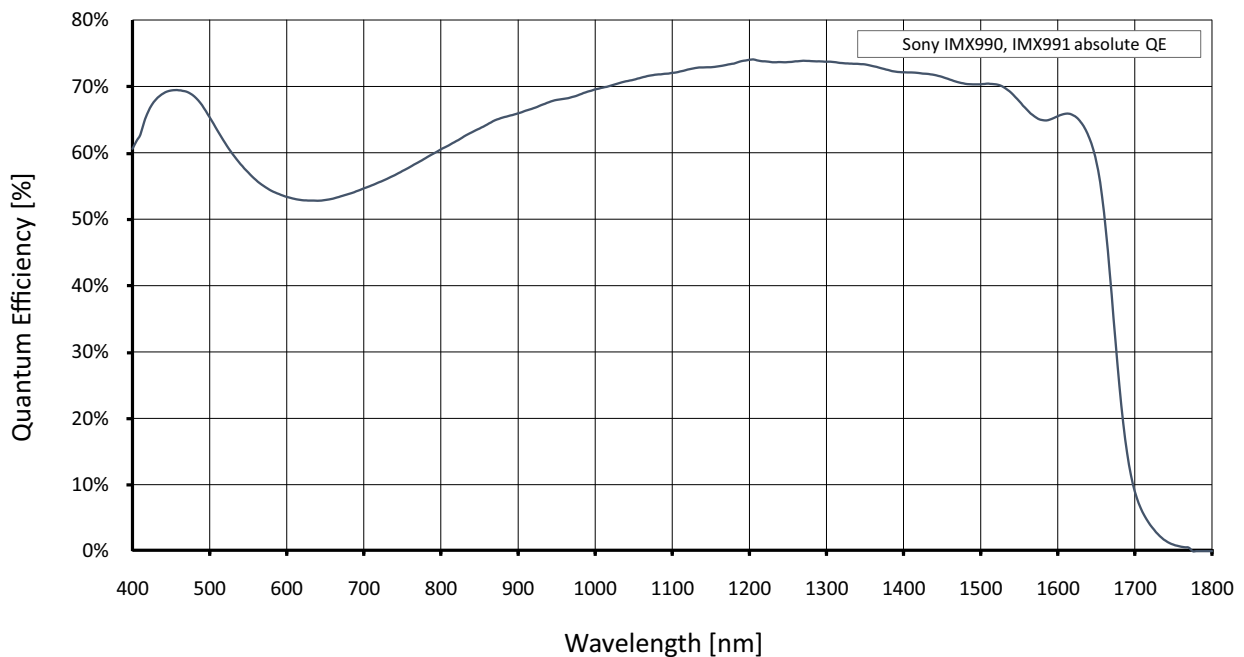

Figure 30: Goldeye CL-130 TEC1 relative QE

## Resolution and ROI frame rates

The maximum frame rate for Goldeye CL-130 TEC1 is determined by the ROI size. Calculate the maximum frame rate using the following formula.

$$\text{SensorFrameRate} = \frac{\text{PF}}{V + 36}$$

$$\text{FrameRate} = \text{MIN}(\text{SensorFrameRate}, \text{GigEFrameRate})$$

PF	Pixel format factor <ul style="list-style-type: none"> <li>• Mono8: 99734.04</li> <li>• Mono12: 75604.84</li> <li>• Mono12p: 75604.84</li> </ul>
V	ROI: vertical resolution (height). The formula is valid if $V \geq 8$ . For V always use the value rounded up to the next multiple of 8.

When using the formula, please consider the following:

- The formula serves as a rough estimation.
- Valid for IntegrateWhileRead-Mode only.
- ROI minimum width and height are 8 pixels.
- Exposure time may reduce the frame rate.
- Computational limitations of the host and image capture software may prevent the camera from achieving maximum frame rates.

*Formula 28: Maximum frame rate for Goldeye CL-130 TEC1*



### ROI frame rates with different setups

Examples for maximum frame rates with Goldeye CL-130 TEC1 for common resolutions are listed in the following tables.

Resolution		Mono8 (2 Taps)			Mono8 (1 Tap)		
Width	Height	25 MHz	55 MHz	85 MHz	25 MHz	55 MHz	85 MHz
1280	1024	34	75	94	18	39	61
1280	720	48	106	131	25	56	87
1024	768	55	122	124	29	65	100
800	600	88	156	156	47	105	156
640	480	132	193	193	73	160	193
320	240	361	361	361	265	361	361
160	120	638	638	638	638	638	638
1280	512	67	149	181	35	78	122
1280	8	1763	2262	2262	1293	2262	2262
8	1024	94	94	94	94	94z	94
8	8	2262	2262	2262	2262	2262	2262

Table 186: Goldeye CL-130 TEC1 ROI frame rates by clock frequency and number of taps for Mono8

Resolution		Mono12 (2 Taps)			Mono12 (1 Tap)		
Width	Height	25 MHz	55 MHz	85 MHz	25 MHz	55 MHz	85 MHz
1280	1024	34	71	71	18	39	61
1280	720	48	100	100	25	56	87
1024	768	55	94	94	29	65	94
800	600	88	118	118	47	105	118
640	480	132	146	146	73	146	146
320	240	273	273	273	265	273	273
160	120	484	484	484	484	484	484
1280	512	67	137	122	35	78	122
1280	8	1718	1718	1718	1293	1718	1718
8	1024	71	71	71	71	71	71
8	8	1718	1718	1718	1718	1718	1718

Table 187: Goldeye CL-130 TEC1 ROI frame rates by clock frequency and number of taps for Mono12

# Technical drawings (GigE models)

## Model overview

You can find drawings for the corresponding models on pages:

Goldeye model	Mount adapters			
	C-Mount Type 1	C-Mount Type 2	F-Mount	M42-Mount
Goldeye G-008 TEC1	189	N.a.	190	191
Goldeye G-008 Cool TEC1	195	N.a.	196	197
Goldeye G-008 1.9/2.2 XSWIR TEC2	N.a.	188		N.a.
Goldeye G-030 TEC1	N.a.	187		N.a.
Goldeye G-032 TEC1	189	N.a.	190	191
Goldeye G-032 Cool TEC2	195	N.a.	196	197
Goldeye G-033 TEC1	189	N.a.	190	191
Goldeye G-033 TECless	189	N.a.	190	191
Goldeye G-034 TEC1	192	N.a.	193	194
Goldeye G-034 TEC2	N.a.	188		N.a.
Goldeye G-034 1.9/2.2 XSWIR TEC2	N.a.	188		N.a.
Goldeye G-130 TEC1	N.a.	187		N.a.

N.a. = Not applicable

Table 188: Technical drawings by Goldeye G model



### Availability of lens mount adapters

See [Lens mount adapters by model](#) on page 208 for C-Mount adapters Type 1 and Type 2, F-Mount adapters, and M42-Mount adapters.

## Goldeye G-030 TEC1, -130 TEC1: C-Mount adapter Type 2

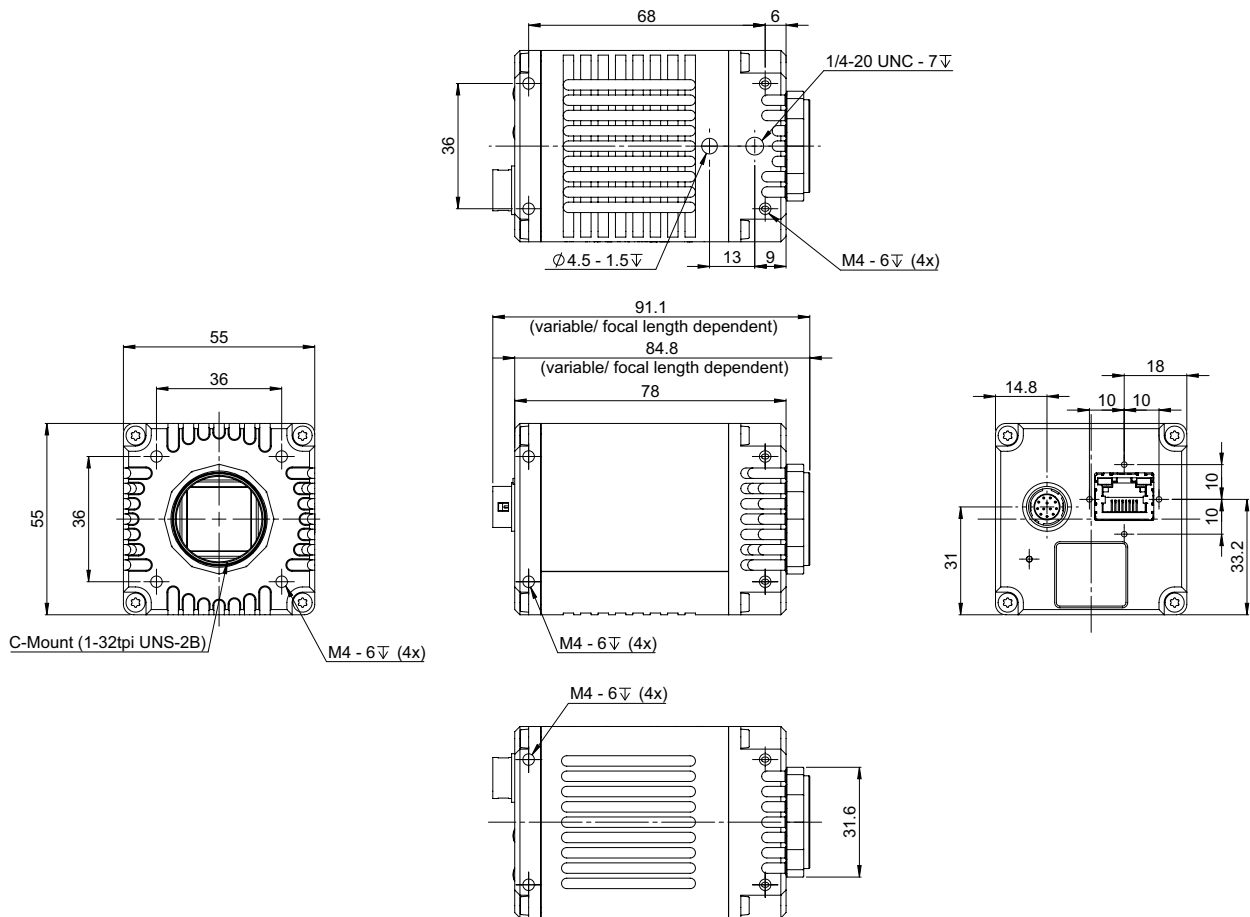

Figure 31: Goldeye G-030 TEC1, -130 TEC1 with C-Mount adapter Type 2

## Goldeye G-008/-034 XSWIR 1.9/2.2 TEC2, -034 TEC2: C-Mount adapter Type 2

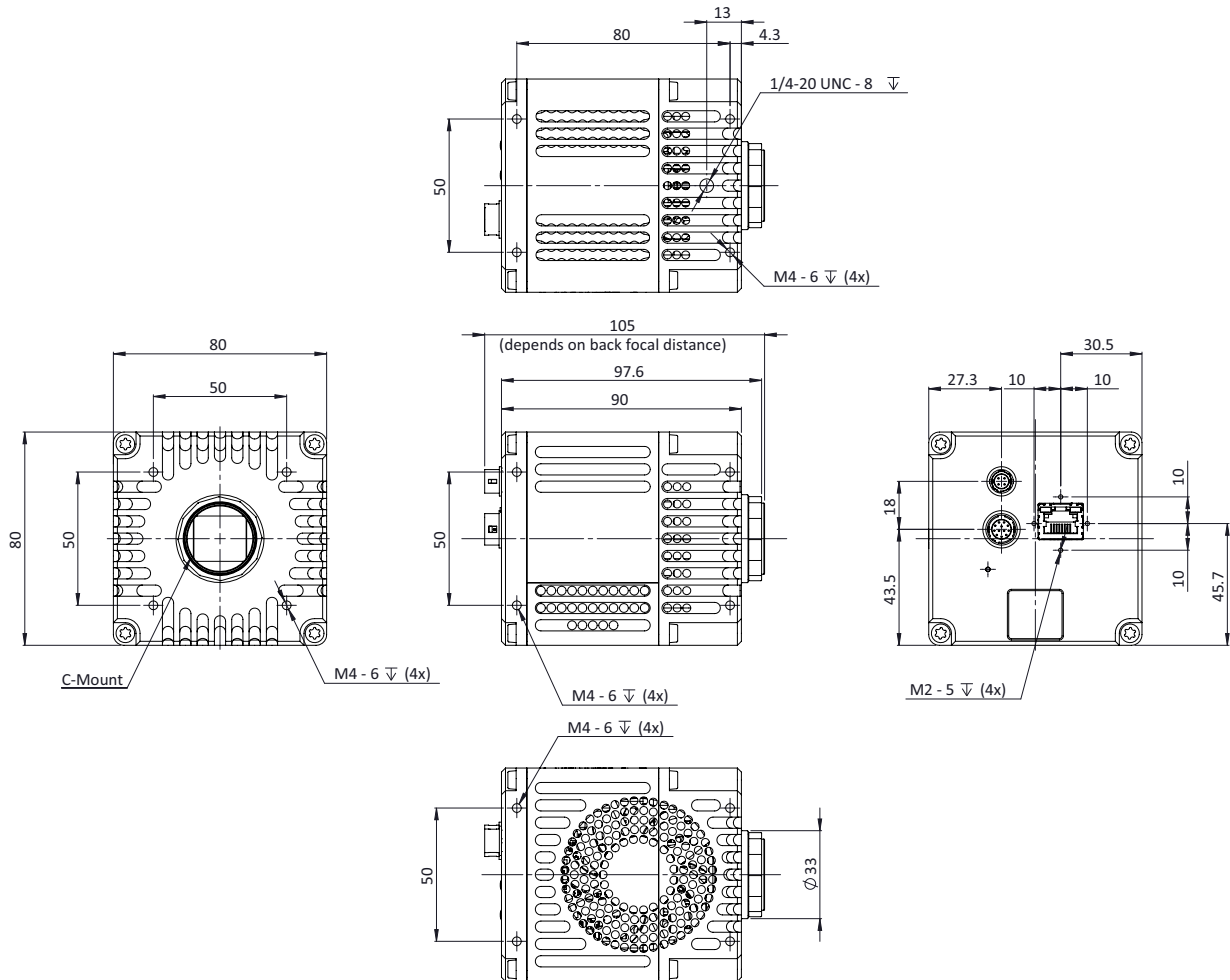

Figure 32: Goldeye G-008 XSWIR 1.9/2.2 TEC2, -034 TEC2, -034 XSWIR 1.9/2.2 TEC2 with C-Mount adapter Type 2

## Goldeye G-008 TEC1, -032 TEC1, -033 TEC1, -033 TECless: C-Mount adapter Type 1

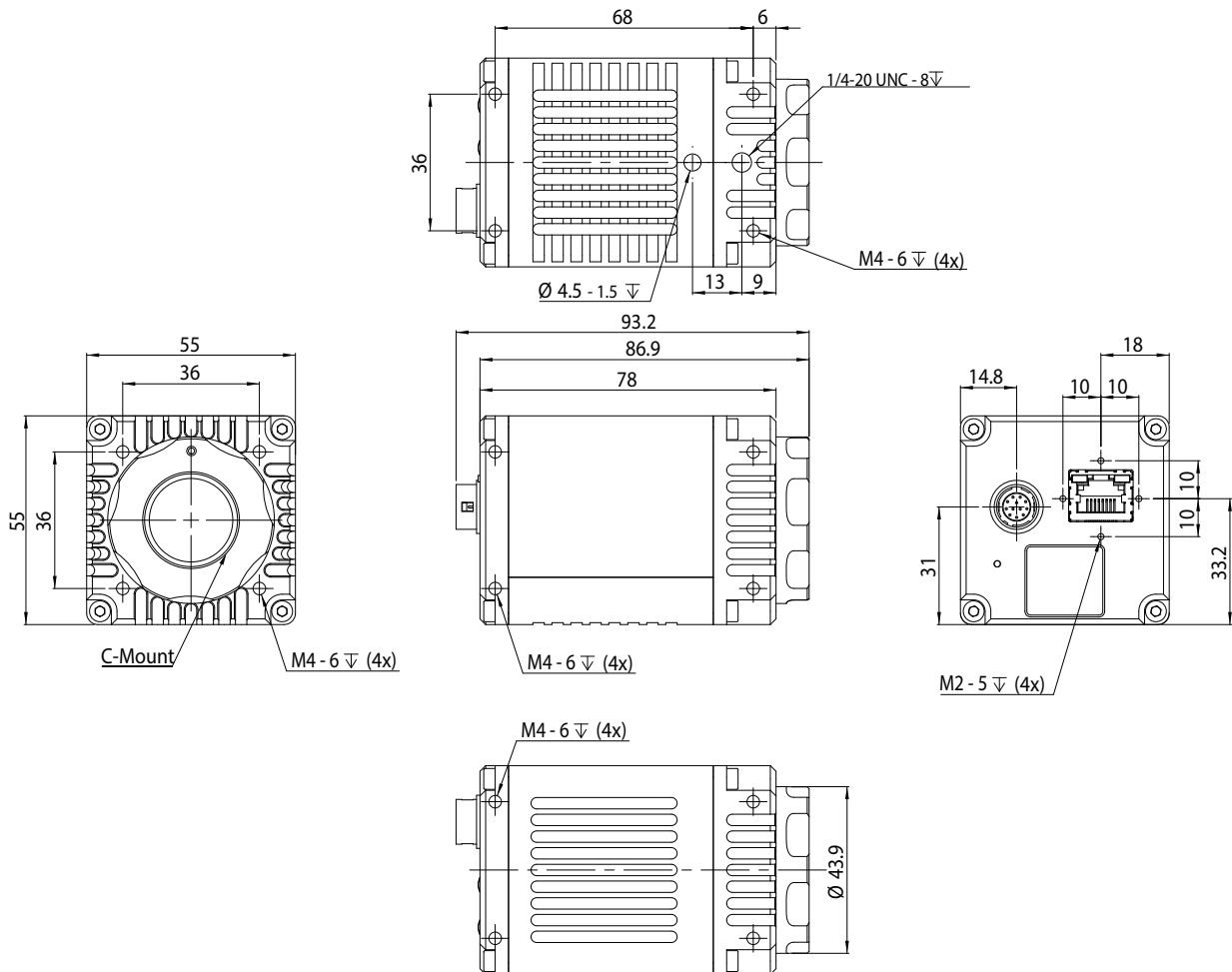

Figure 33: Goldeye G-008 TEC1, -032 TEC1, -033 TEC1, -033 TECless with C-Mount adapter Type 1

## Goldeye G-008 TEC1, -032 TEC1, -033 TEC1, -033 TECless: F-Mount adapter

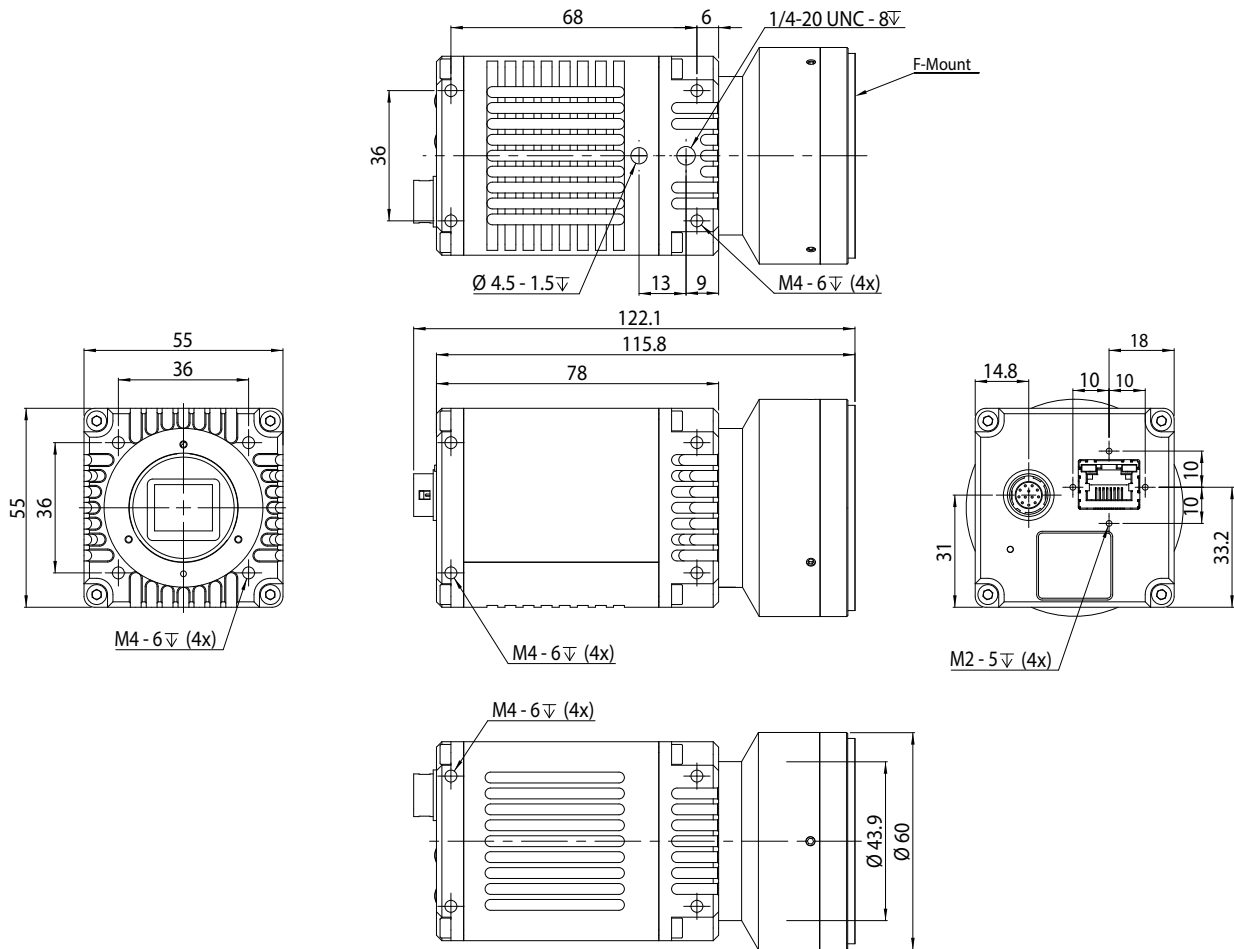

Figure 34: Goldeye G-008 TEC1, -032 TEC1, -033 TEC1, -033 TECless with F-Mount adapter

## Goldeye G-008 TEC1, -032 TEC1, -033 TEC1, -033 TECless: M42-Mount adapter

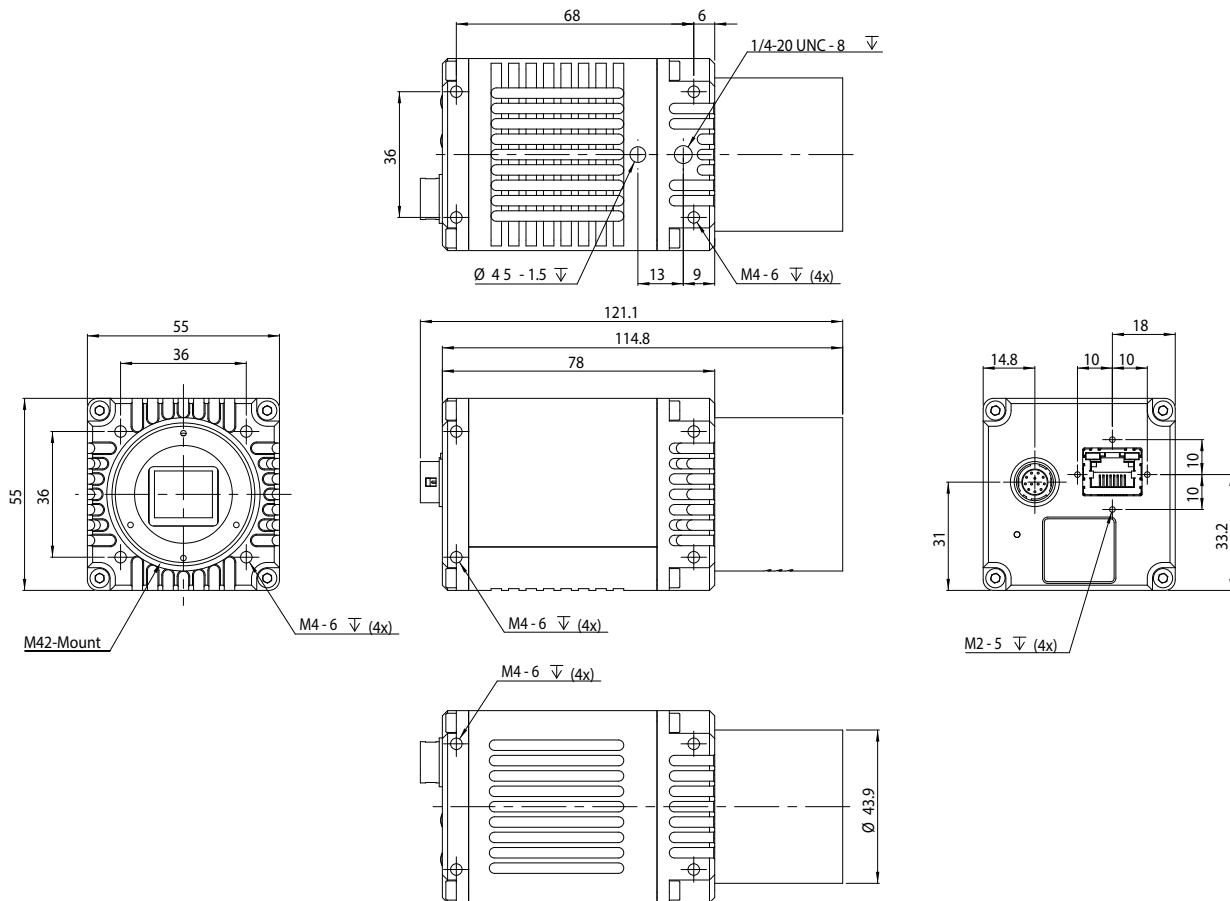

Figure 35: Goldeye G-008 TEC1, -032 TEC1, -033 TEC1, -033 TECless with M42-Mount adapter

## Goldeye G-034 TEC1: C-Mount adapter Type 1

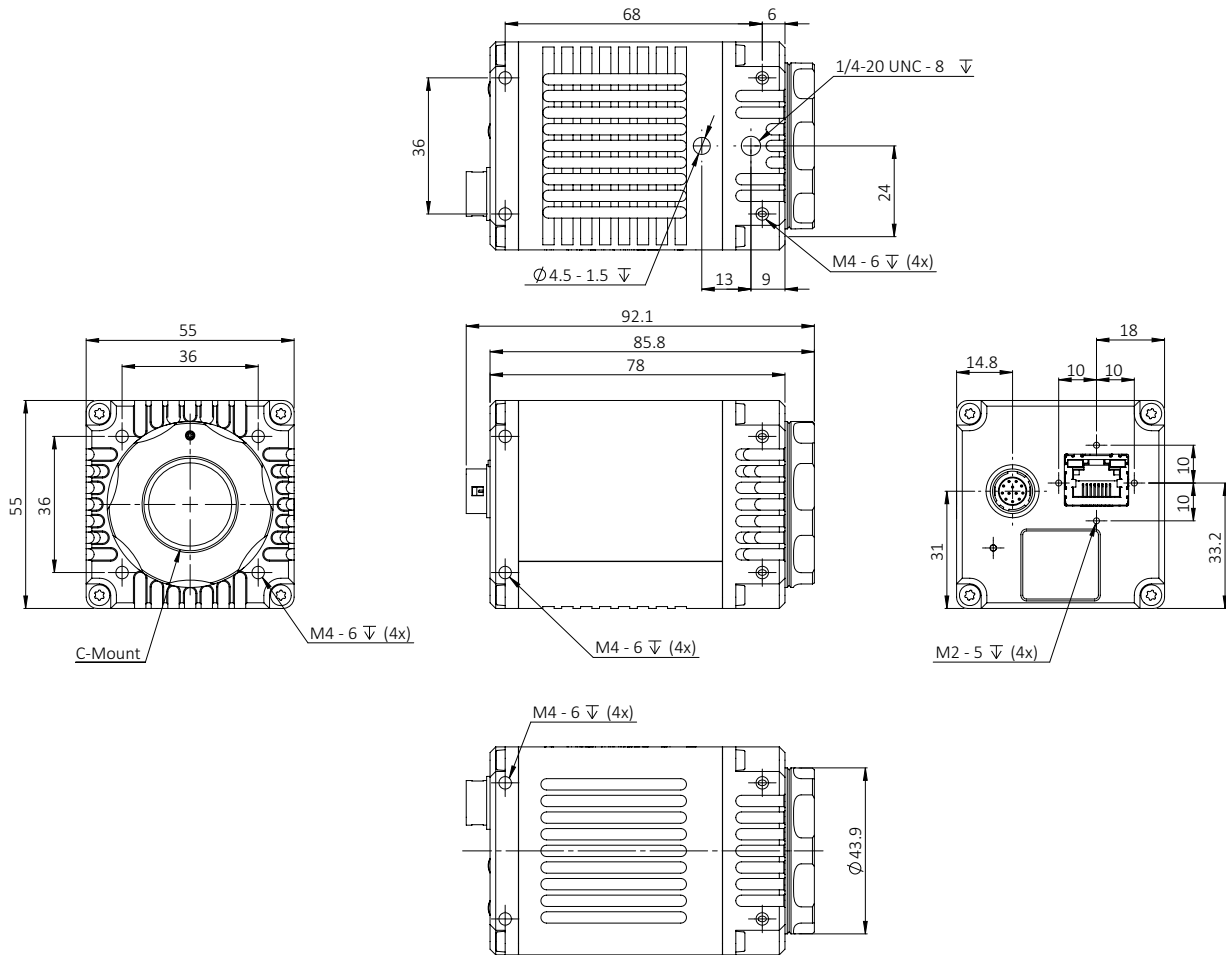

Figure 36: Goldeye G-034 TEC1 with C-Mount adapter Type 1



## Goldeye G-034 TEC1: F-Mount adapter

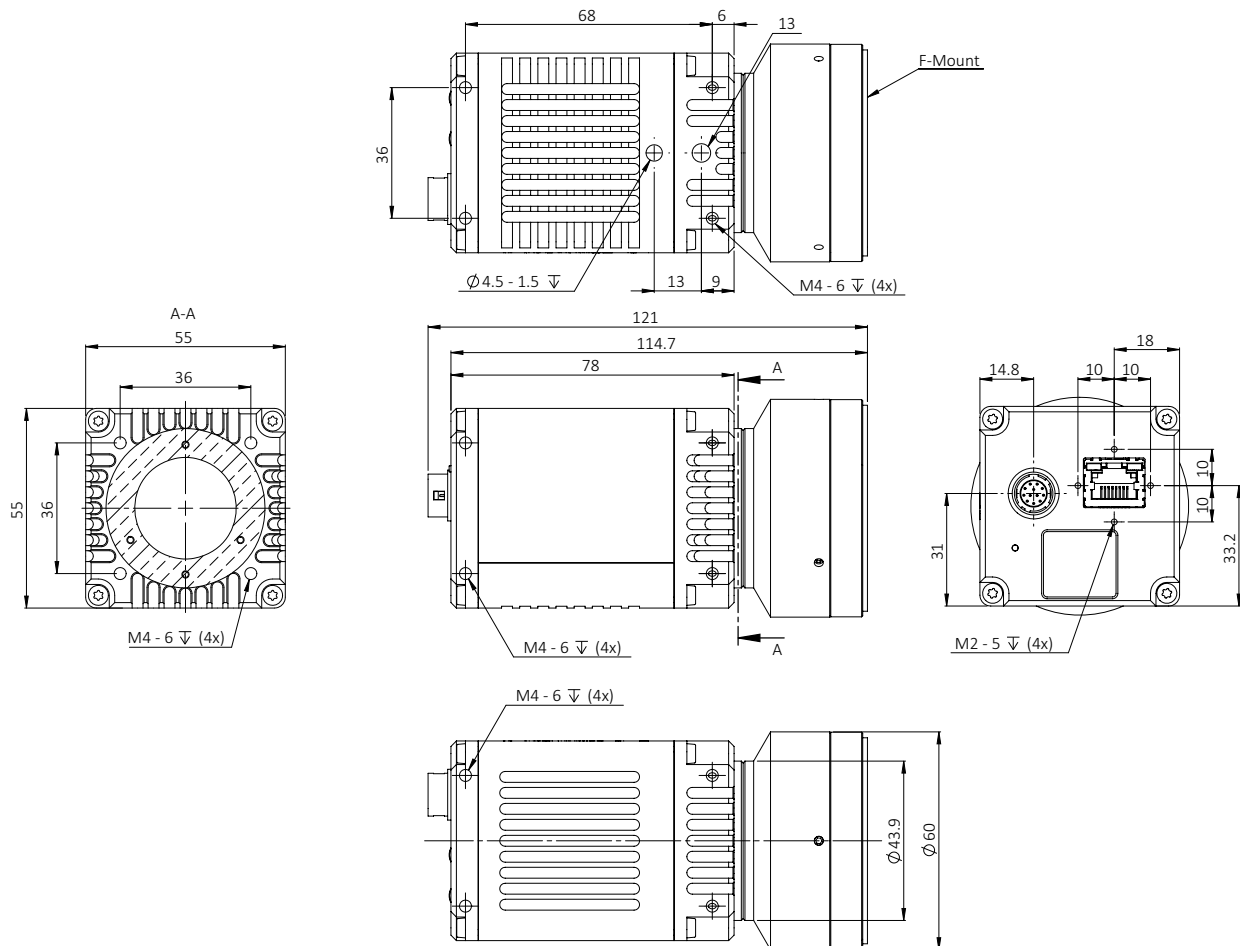

Figure 37: Goldeye G-034 TEC1 with F-Mount adapter

## Goldeye G-034 TEC1: M42-Mount adapter

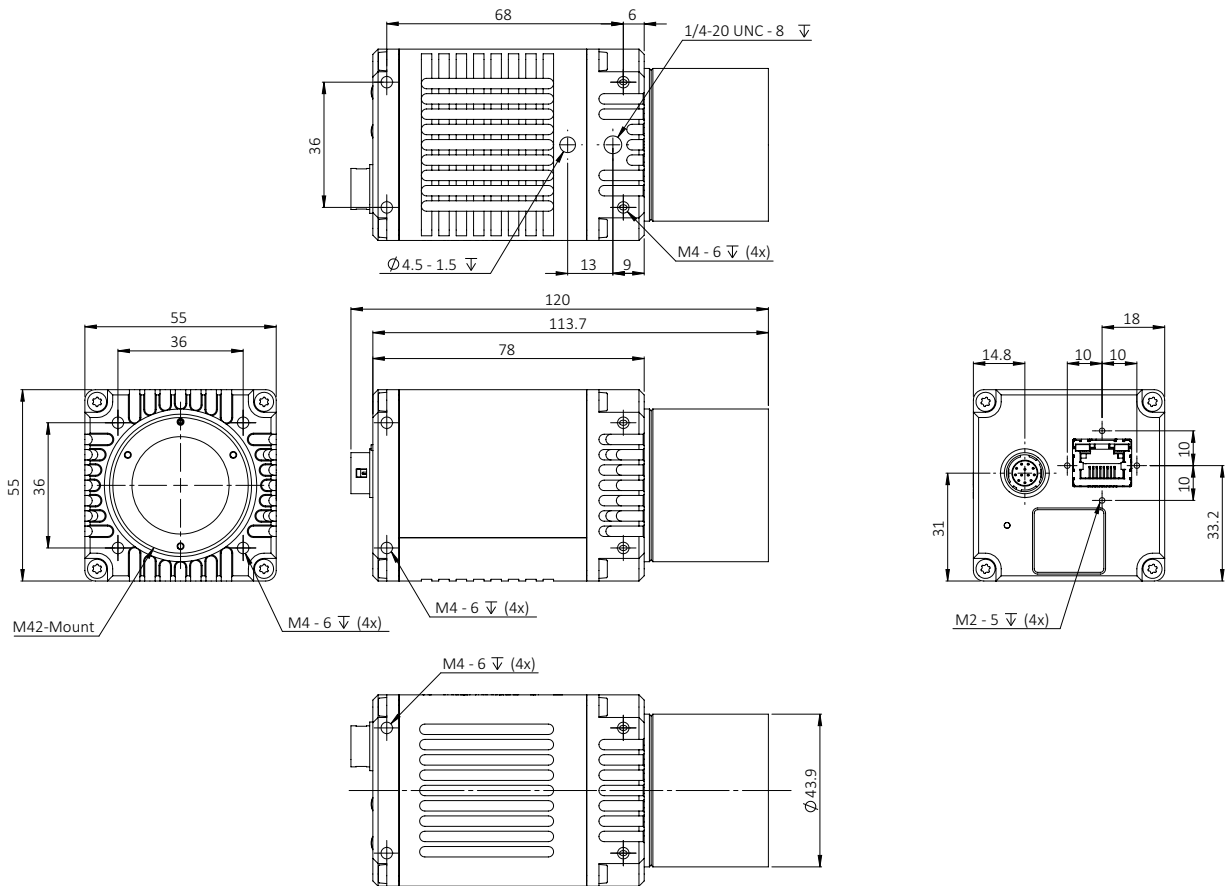

Figure 38: Goldeye G-034 TEC1 with M42-Mount adapter

## Goldeye G-008 Cool TEC1, -032 Cool TEC2: C-Mount adapter Type 1

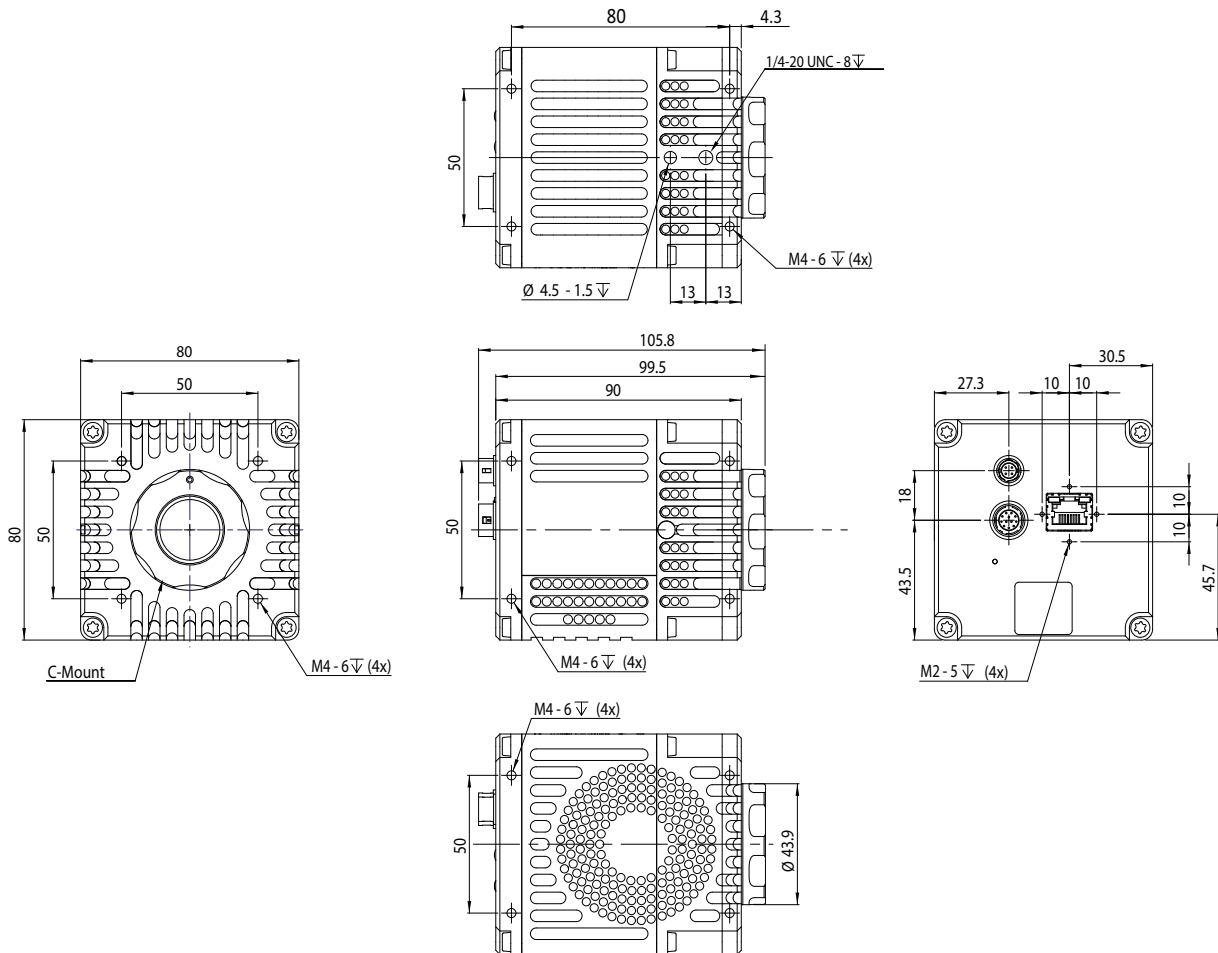

Figure 39: Goldeye G-008 Cool TEC1, -032 Cool TEC2 with C-Mount adapter Type 1

## Goldeye G-008 Cool TEC1, -032 Cool TEC2: F-Mount adapter

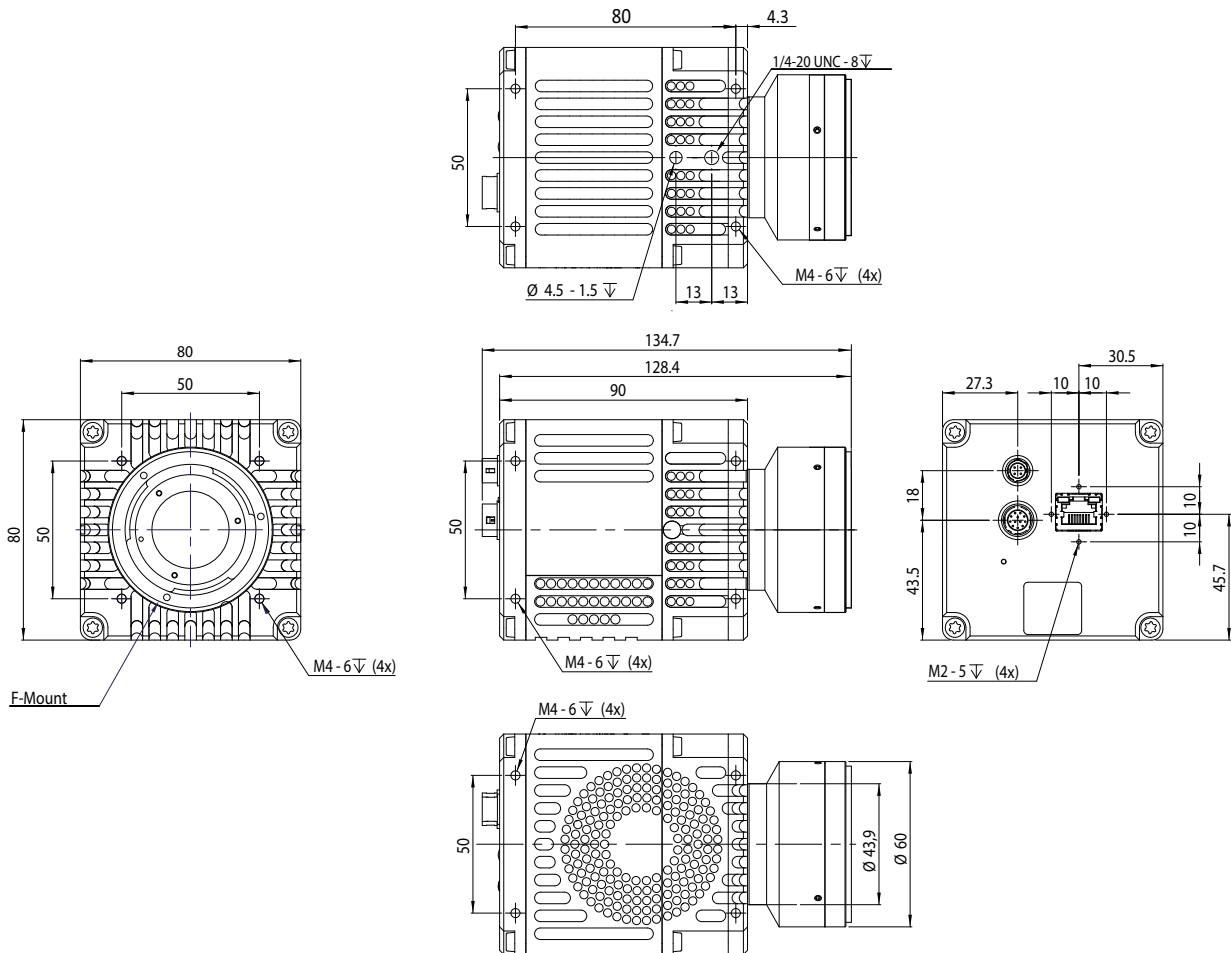
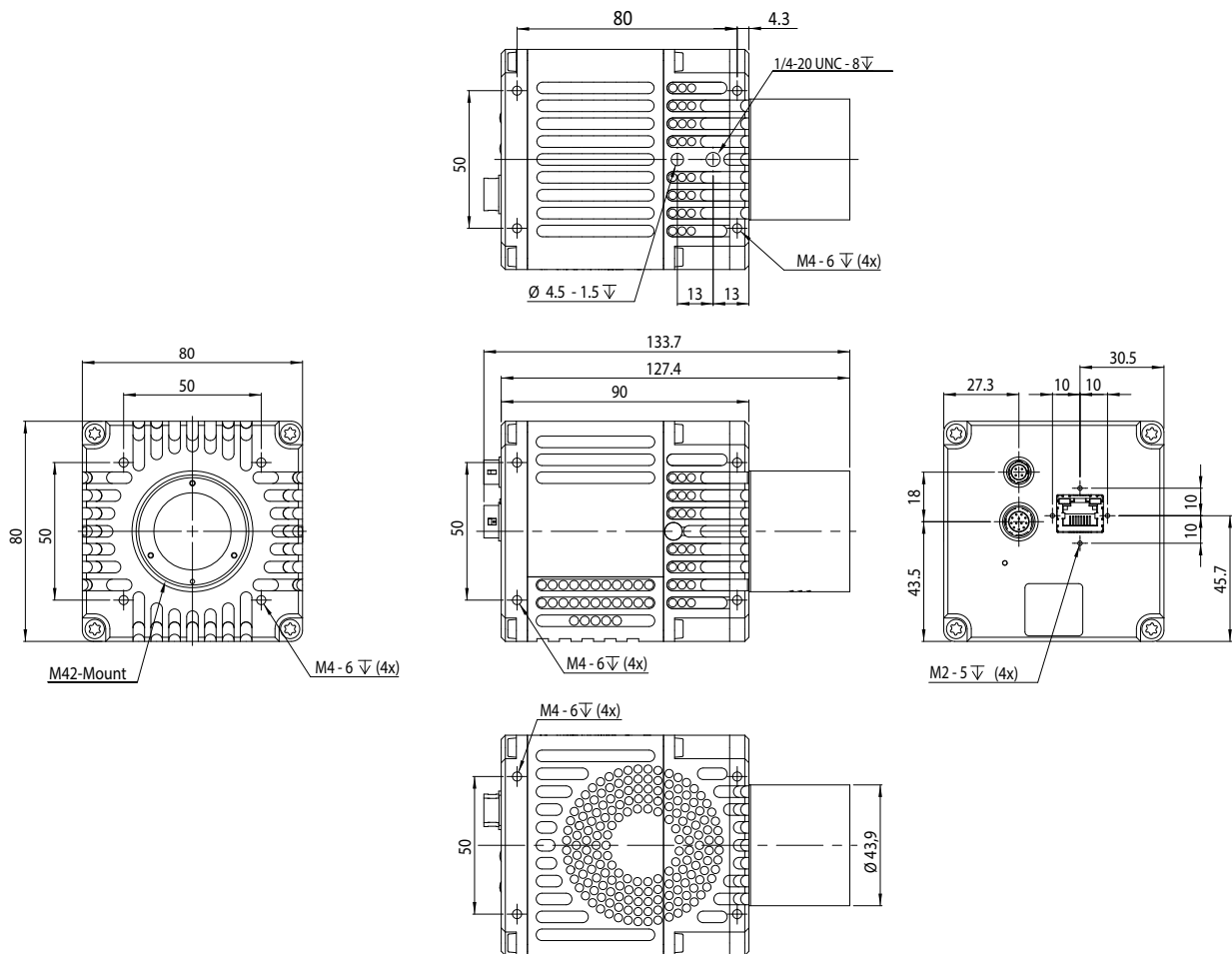

Figure 40: Goldeye G-008 Cool TEC1, -032 Cool TEC2 with F-Mount adapter

## Goldeye G-008 Cool TEC1, -032 Cool TEC2: M42-Mount adapter



*Figure 41: Goldeye G-008 Cool TEC1, -032 Cool TEC2 with M42-Mount adapter*

# Technical drawings (CL models)

## Model overview

You can find drawings for the corresponding models on pages:

Goldeye model	Mount adapters			
	C-Mount Type 1	C-Mount Type 2	F-Mount	M42-Mount
Goldeye CL-008 TEC1	<a href="#">201</a>	N.a.	<a href="#">202</a>	<a href="#">203</a>
Goldeye CL-008 Cool TEC1	<a href="#">207</a>	N.a.	On request	
Goldeye CL-008 XSWIR 1.9/2.2 TEC2	N.a.	<a href="#">200</a>	N.a.	
Goldeye CL-030 TEC1	N.a.	<a href="#">199</a>	N.a.	
Goldeye CL-032 TEC1	<a href="#">201</a>	N.a.	<a href="#">202</a>	<a href="#">203</a>
Goldeye CL-032 Cool TEC2	<a href="#">207</a>	N.a.	On request	
Goldeye CL-033 TEC1	<a href="#">201</a>	N.a.	<a href="#">202</a>	<a href="#">203</a>
Goldeye CL-033 TECless	<a href="#">201</a>	N.a.	<a href="#">202</a>	<a href="#">203</a>
Goldeye CL-034 TEC1	<a href="#">204</a>	N.a.	<a href="#">205</a>	<a href="#">206</a>
Goldeye CL-034 TEC2	N.a.	<a href="#">200</a>	N.a.	
Goldeye CL-034 XSWIR 1.9/2.2 TEC2	N.a.	<a href="#">200</a>	N.a.	
Goldeye CL-030 TEC1	N.a.	<a href="#">199</a>	N.a.	

N.a. = Not applicable

*Table 189: Technical drawings by Goldeye CL model*



### Availability of lens mount adapters

See [Lens mount adapters by model](#) on page 208 for C-Mount adapters Type 1 and Type 2, F-Mount adapters, and M42-Mount adapters.

## Goldeye CL-030 TEC1, -130 TEC1: C-Mount adapter Type 2

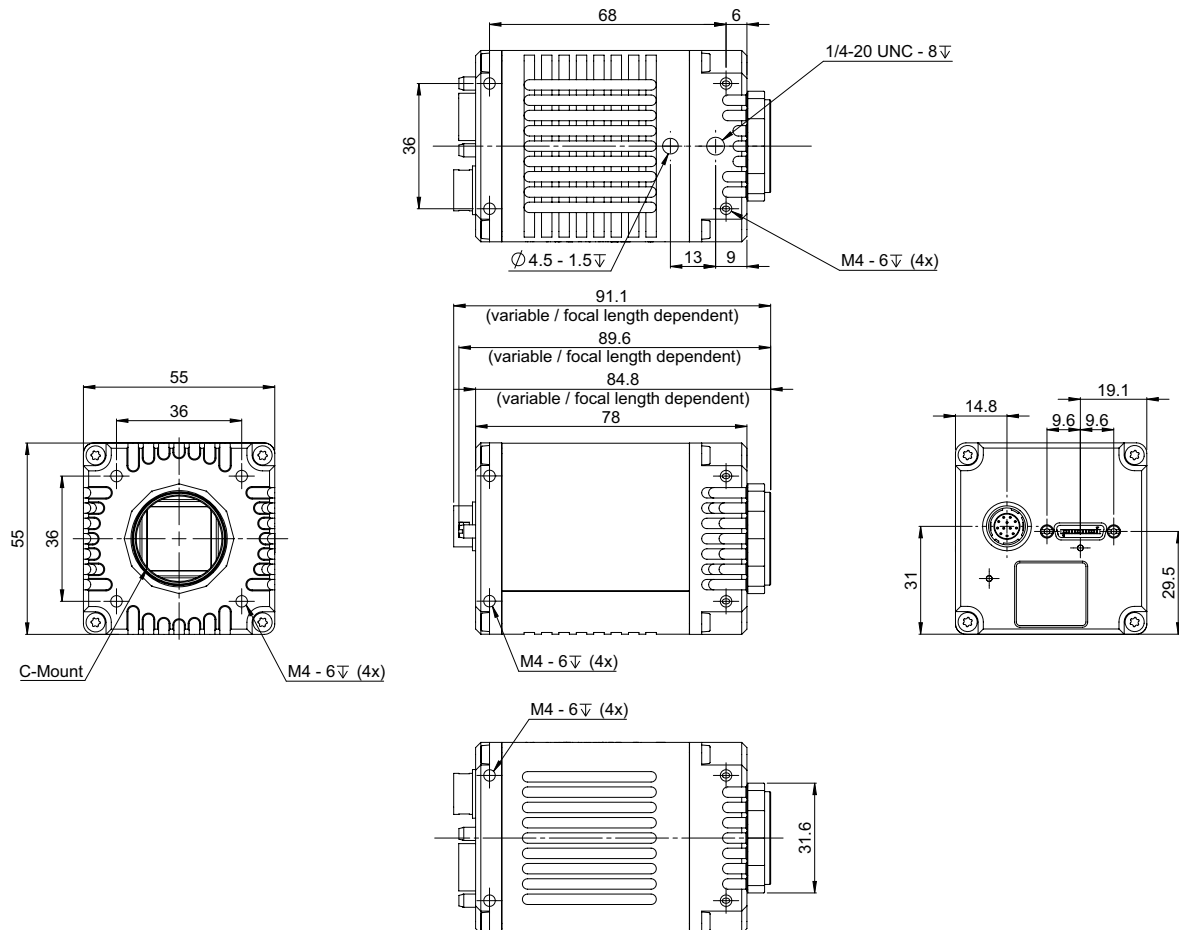

Figure 42: Goldeye CL-030 TEC1, -130 TEC1 with C-Mount adapter Type 2

## Goldeye CL-008/-034 XSWIR 1.9/2.2 TEC2, -034 TEC2: C-Mount adapter Type 2

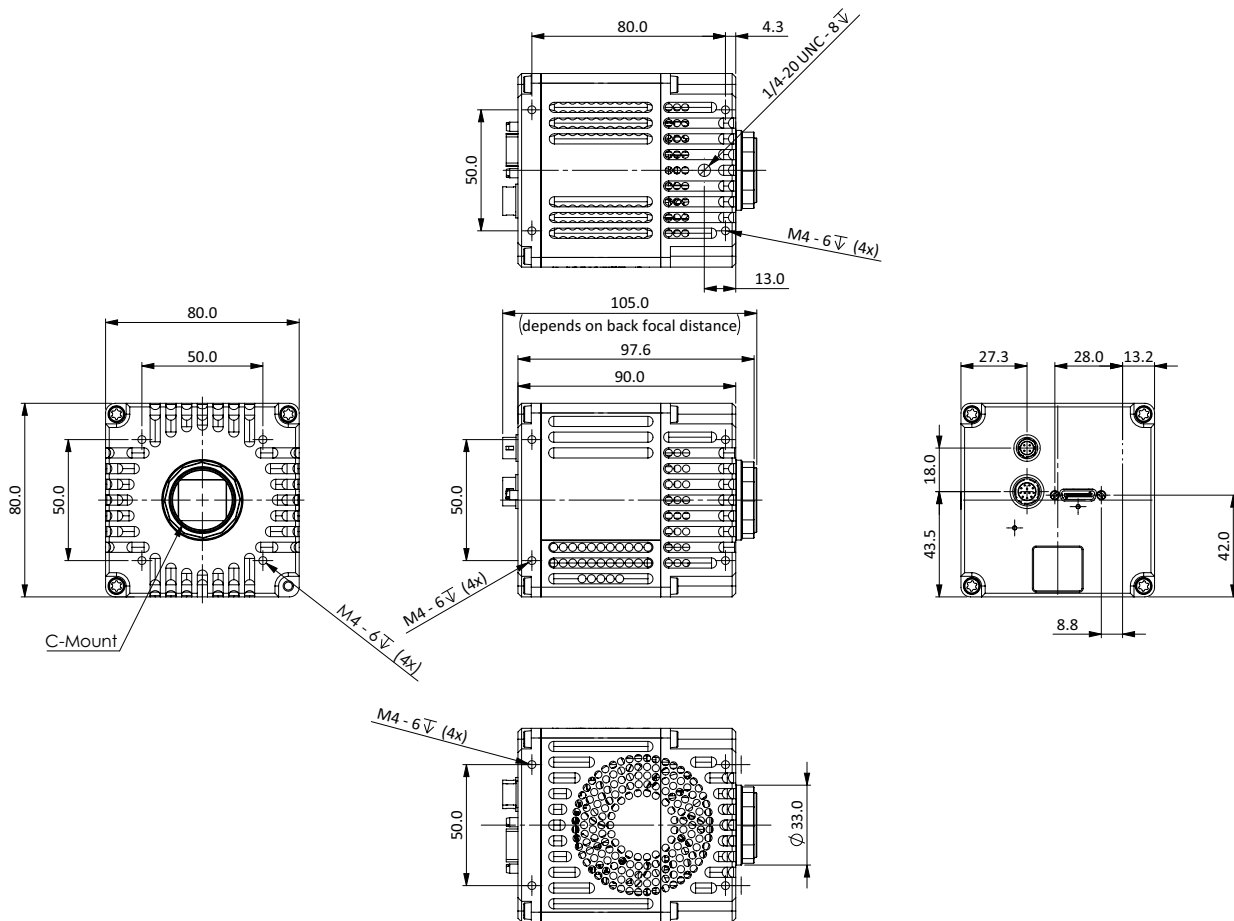

Figure 43: Goldeye CL-008 XSWIR 1.9/2.2 TEC2, -034 TEC2,  
-034 XSWIR 1.9/2.2 TEC2 with C-Mount adapter Type 2



### Availability

Goldeye CL-008 XSWIR 1.9/2.2 TEC2, CL-034 XSWIR 1.9/2.2 TEC2



## Goldeye CL-008 TEC1, -032 TEC1, -033 TEC1, -033 TECless: C-Mount adapter Type 1

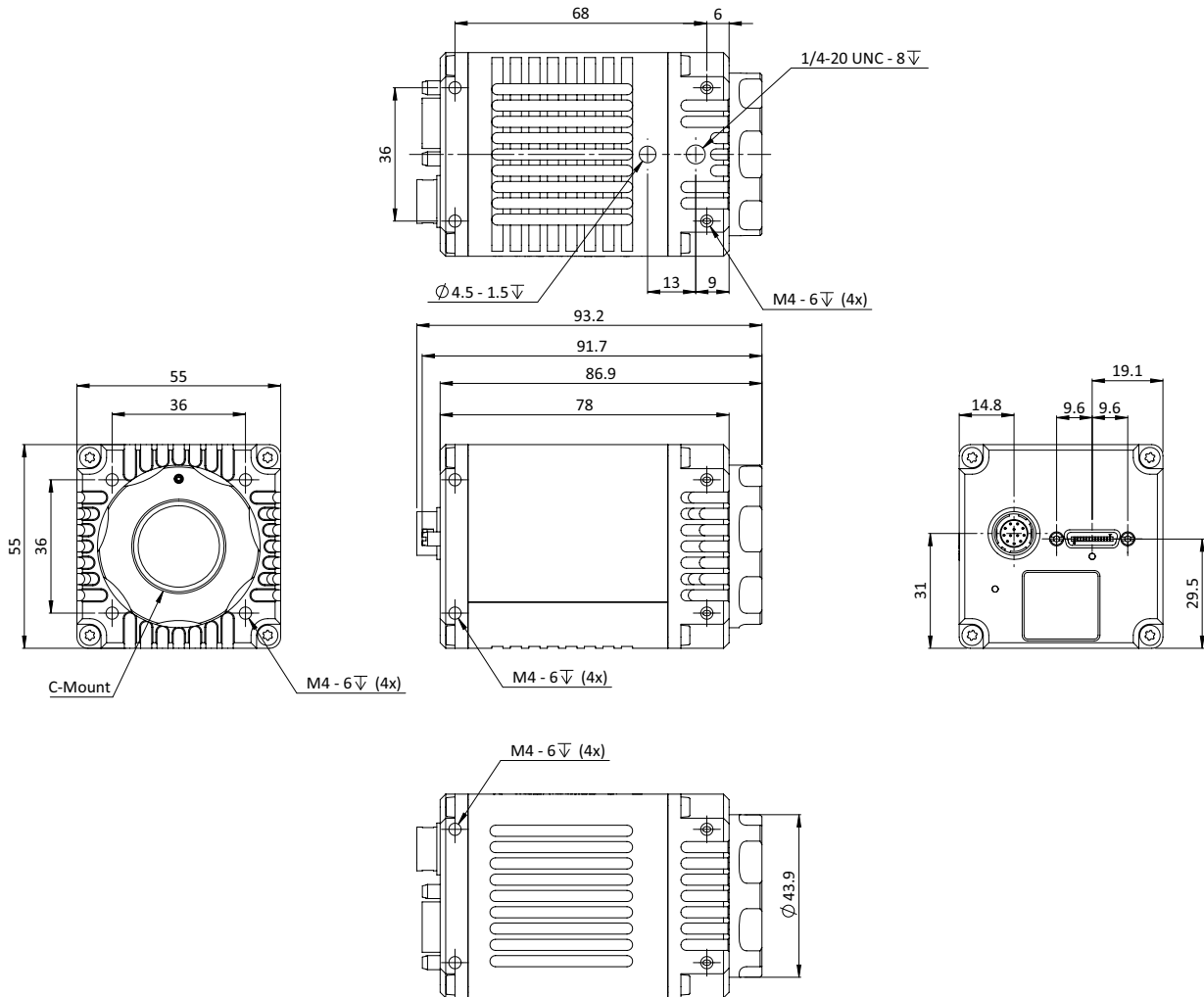

Figure 44: Goldeye CL-008 TEC1, -032 TEC1, -033 TEC1, -033 TECless with C-Mount adapter Type 1

## Goldeye CL-008 TEC1, -032 TEC1, -033 TEC1, -033 TECless: F-Mount adapter

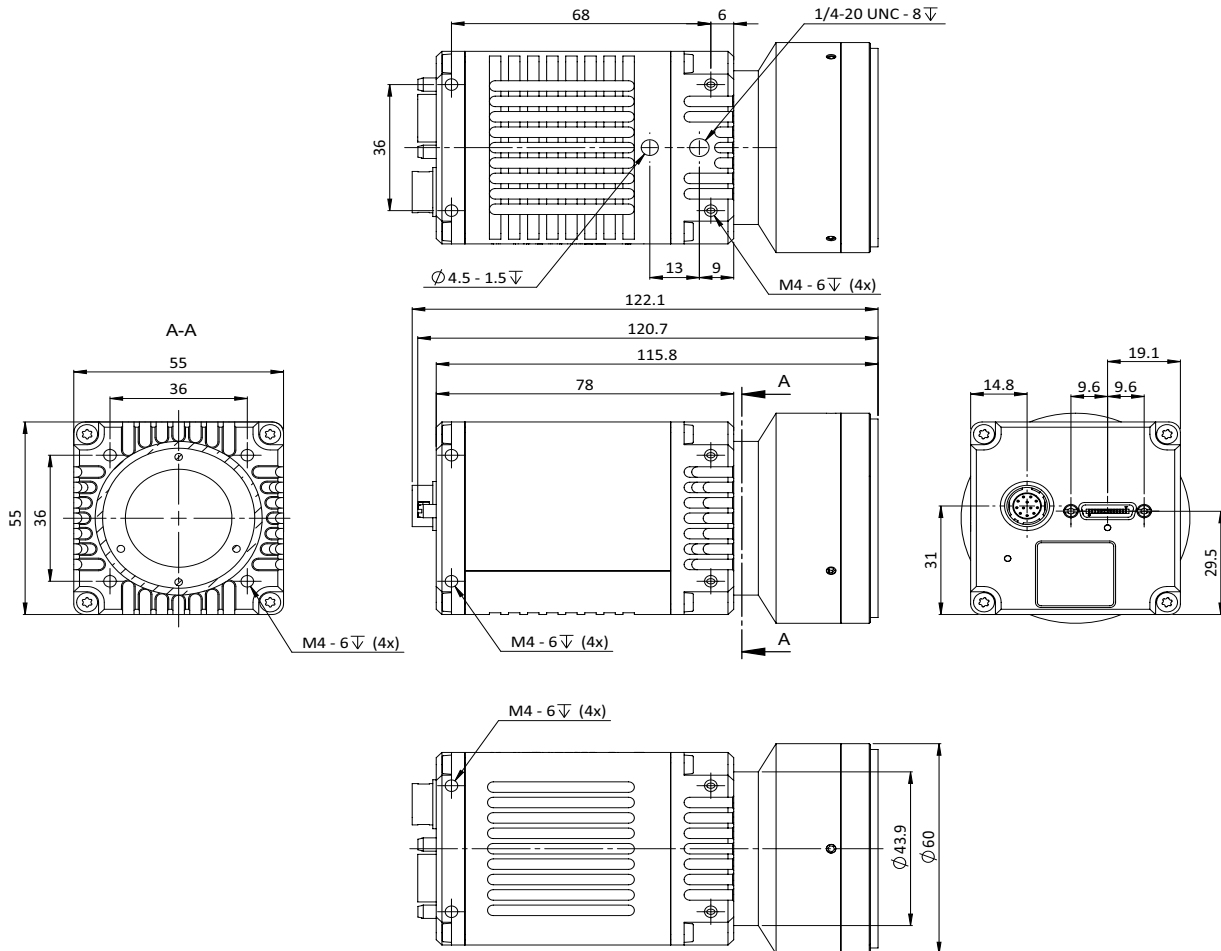

Figure 45: Goldeye CL-008 TEC1, -032 TEC1, -033 TEC1, -033 TECless with F-Mount adapter

## Goldeye CL-008 TEC1, -032 TEC1, -033 TEC1, -033 TECless: M42-Mount adapter

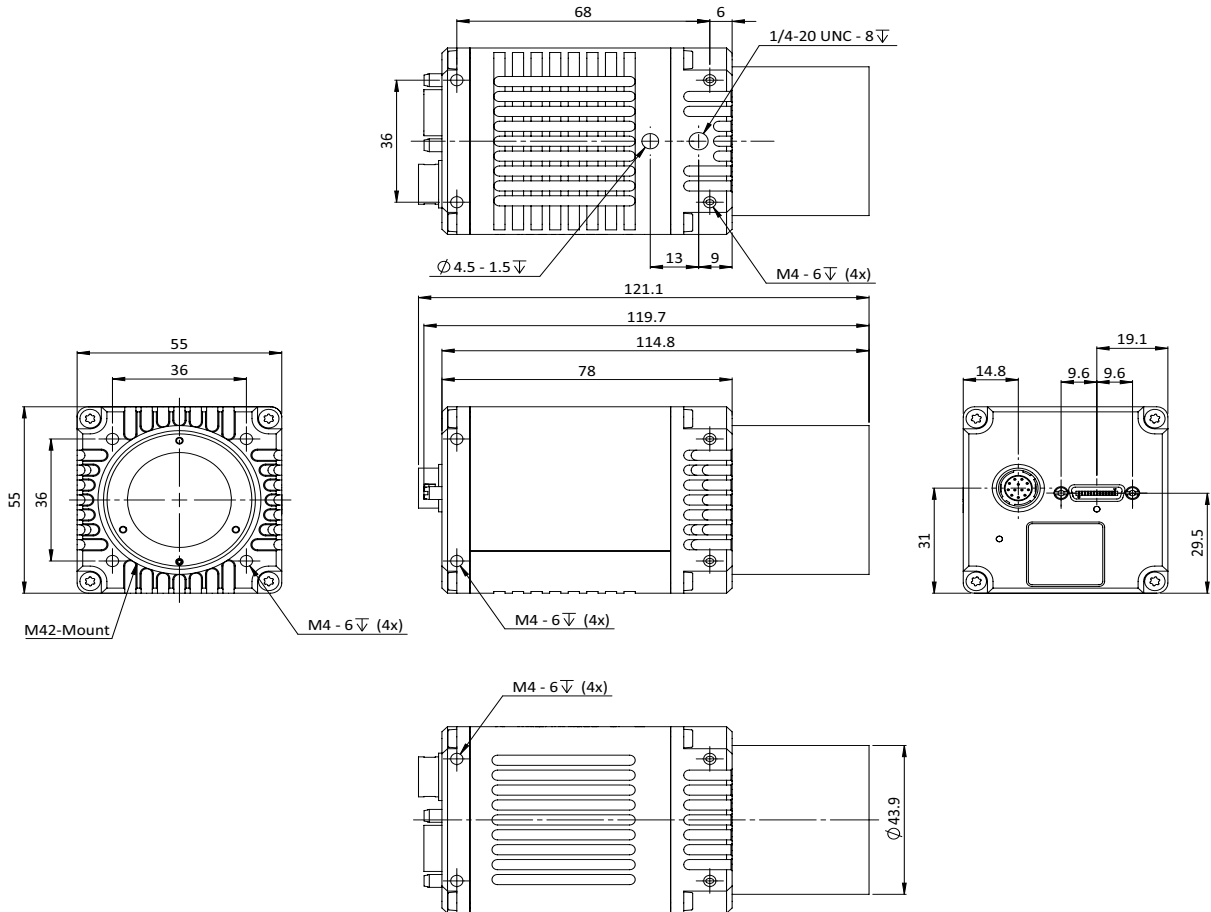

Figure 46: Goldeye CL-008 TEC1, -032 TEC1, -033 TEC1, -033 TECless with M42-Mount adapter

## Goldeye CL-034 TEC1: C-Mount adapter Type 1

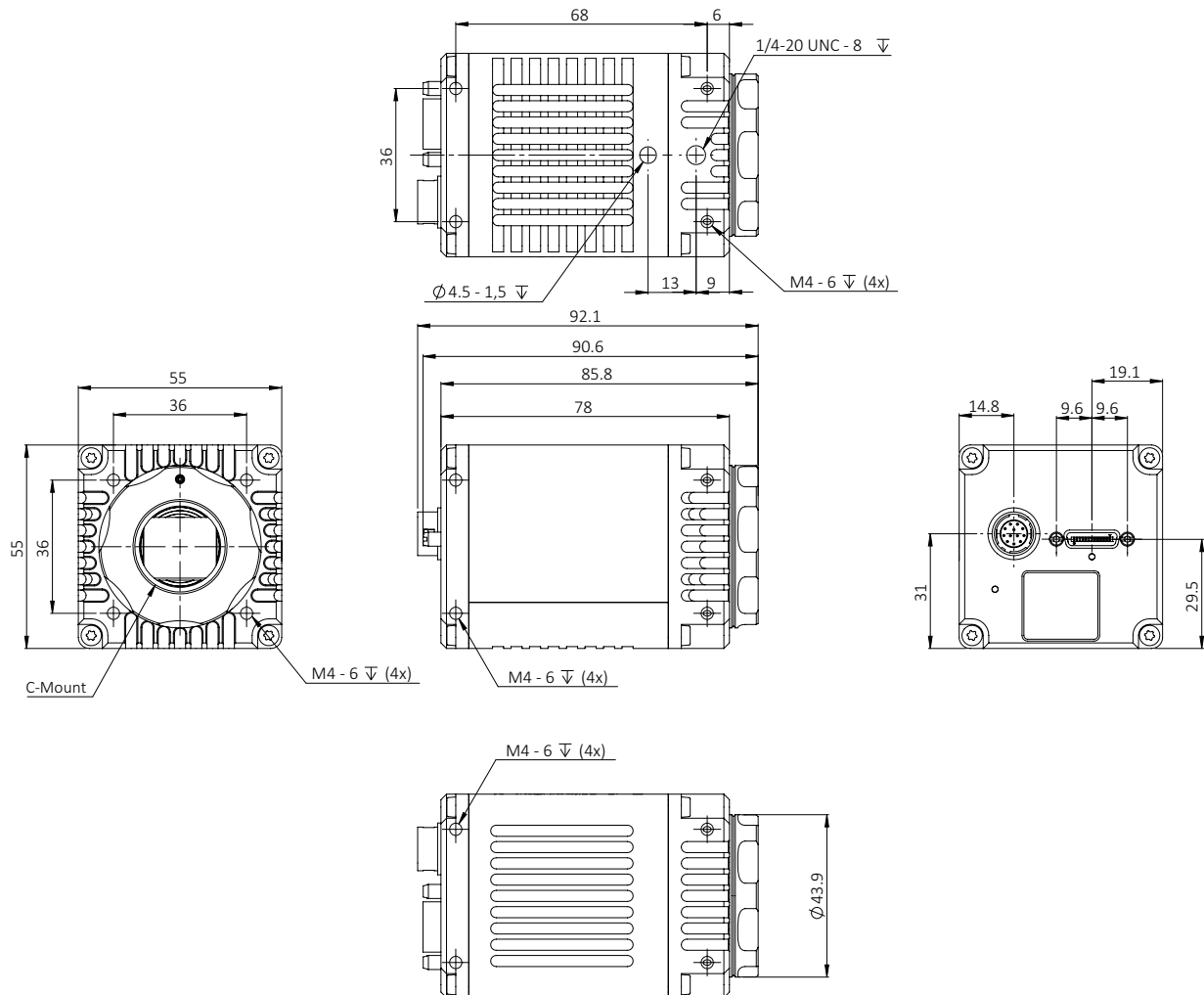

Figure 47: Goldeye CL-034 TEC1 with C-Mount adapter Type 1

## Goldeye CL-034 TEC1: F-Mount adapter

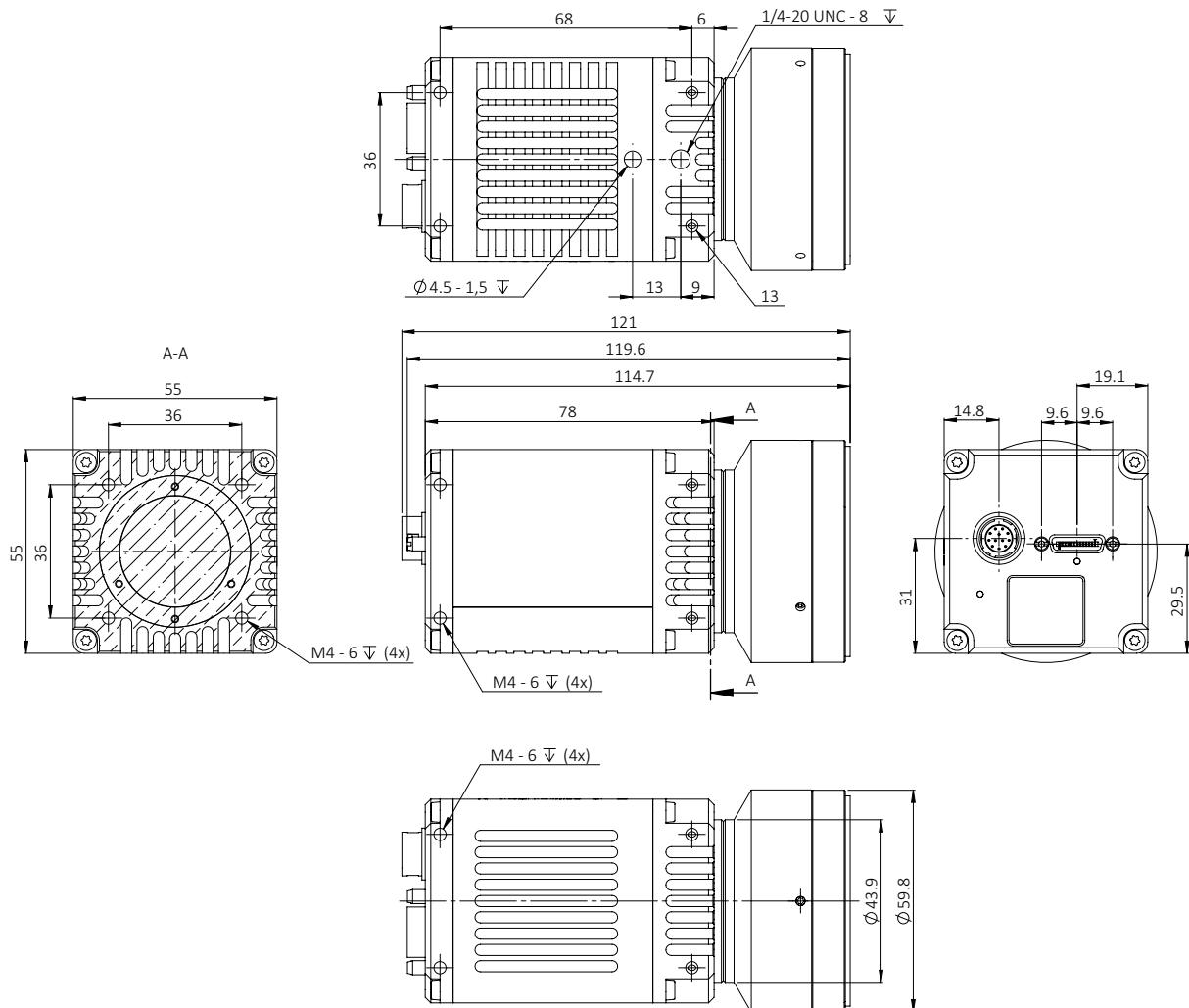

Figure 48: Goldeye CL-034 TEC1 with F-Mount adapter

## Goldeye CL-034 TEC1: M42-Mount adapter

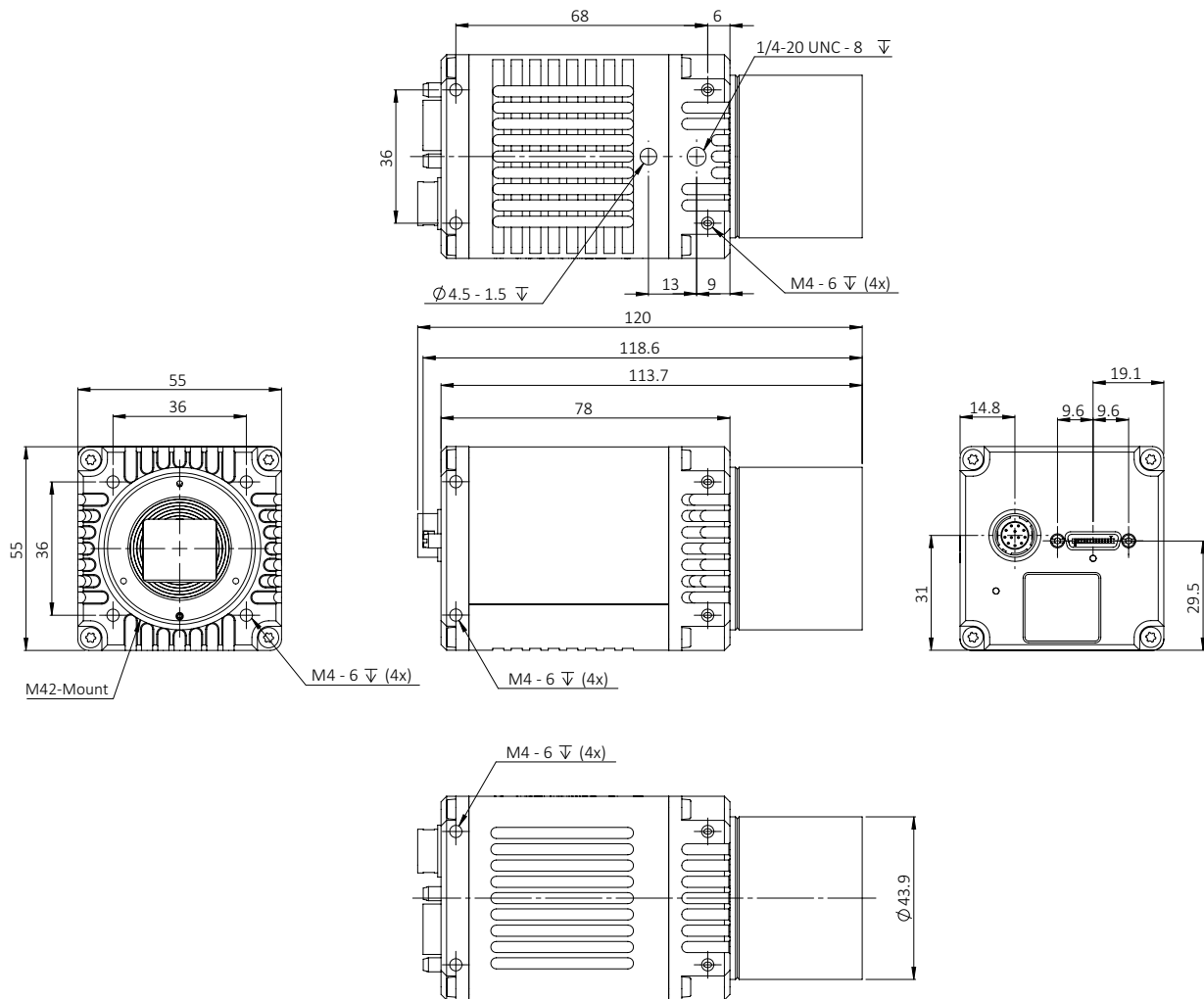

Figure 49: Goldeye CL-034 TEC1 dimensions with M42-Mount adapter

## Goldeye CL-008 Cool TEC1, -032 Cool TEC2: C-Mount adapter Type 1

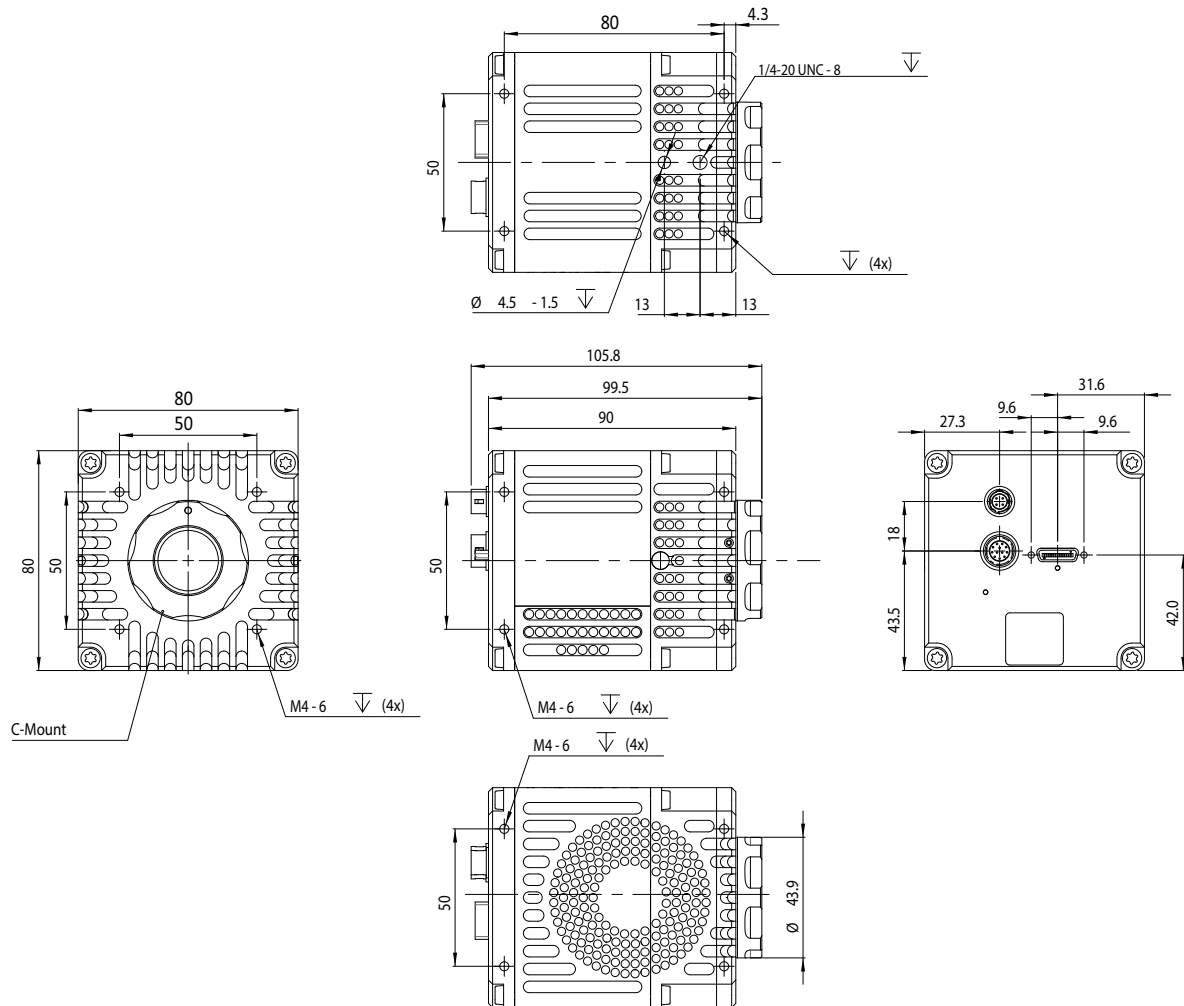

Figure 50: Goldeye CL-008 Cool TEC1, -032 Cool TEC2 with C-Mount adapter Type 1

# Specifications of lens mount adapters

## Lens mount adapters by model

Some Goldeye G/CL models are equipped with a C-Mount adapter by default. Other Goldeye G/CL models are available with separate lens adapters for C-Mount and F-Mount, fitting into the M42-Mount of the camera front flange. To avoid damage to the camera by lens protrusion, a separate lens adapter for M42-Mount is offered for these models as well. See [Table 190](#).

For readily assembled mount adapters with special-purpose optical filter, see [Bandpass filter 1450 nm \(water filter\)](#) on page 229.

Goldeye models	C-Mount	F-Mount	M42-Mount	Filter recess
Goldeye G/CL-008 TEC1,-008 Cool TEC1	✓ <b>Type 1</b>	✓	✓	✓
Goldeye G/CL-032 TEC1,-032 Cool TEC2				
Goldeye G/CL-033 TEC1,-033 TEC-less				
Goldeye G/CL-034 TEC1				
Goldeye G/CL-008 XSWIR 1.9/2.2 TEC2	✓ <b>Type 2</b>	—	—	—
Goldeye G/CL-030 TEC1				
Goldeye G/CL-034 TEC2				
Goldeye G/CL-034 XSWIR 1.9/2.2 TEC2				
Goldeye G/CL-130 TEC1				

Table 190: Lens mount adapters by model



### Type 1 and Type 2 for C-Mount adapters

These adapters support standard C-Mount lenses. Type 1 and 2 is used in this document to separate between additional options for lens mounts and filters.



## Lens mount adapters: Specifications

Parameter	C-Mount adapter (Type 1) <sup>1</sup>	C-Mount adapter (Type 2) <sup>1</sup>	F-Mount adapter	M42-Mount adapter
Suitable optical filter, diameter	25.0 to 25.5 mm	Filters with C-Mount ring	29.5 to 30.1 mm	29.5 to 30.1 mm
Suitable optical filter, thickness	Maximum 2.5 mm <sup>(2)</sup>	Depending on the filter	2.0 to 2.5 mm	2.0 to 2.5 mm
Max. protrusion with filter	6.6 mm	11.0 mm minus filter <sup>(3)</sup> 11.7 mm minus filter <sup>(4)</sup>	35.1 mm <sup>(5)</sup>	34.1 mm <sup>(6)</sup>

<sup>1</sup> See [Lens mount adapters by model](#) on page 208 for supported models.

<sup>2</sup> Goldeye G/CL-034: Max. 2.0 mm | <sup>3</sup> Goldeye G/CL-008 XSWIR 1.9/2.2 TEC2, -034 TEC2, -034 XSWIR 1.9/2.2 TEC2

<sup>4</sup> Goldeye G/CL-030 TEC1, -130 TEC1 | <sup>5</sup> Goldeye G/CL-034: Maximum protrusion with filter is 34.0 mm.

<sup>6</sup> Goldeye G/CL-034: Maximum protrusion with filter is 34.8 mm with a filter diameter of up to 33.0 mm.

Table 191: Specifications of mount adapters

## Lens mount adapters: Maximum protrusion

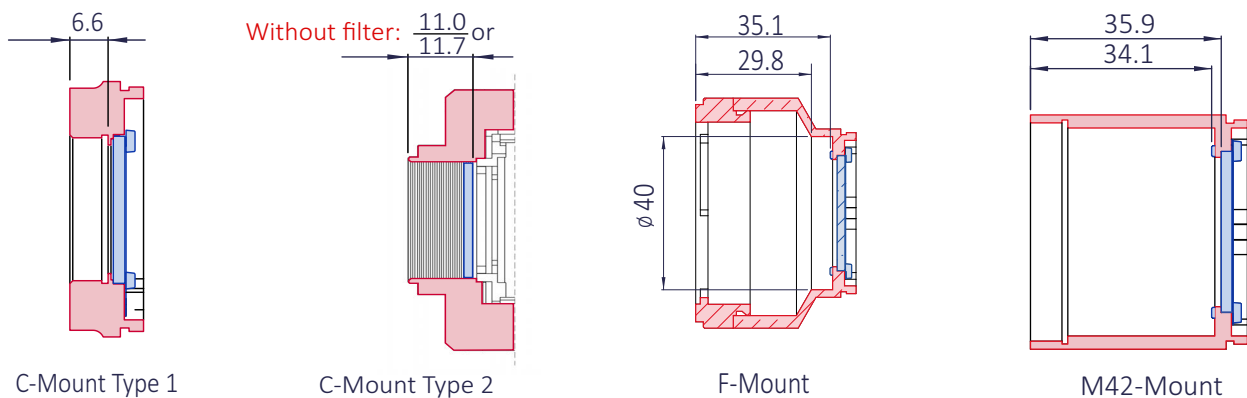

Figure 51: Adapters (red) with filters (blue) and maximum protrusion

## Lens mount adapters: Ordering



### Availability of lens mount adapters

See [Lens mount adapters by model](#) on page 208 for C-Mount adapters Type 1 and Type 2, F-Mount adapters, and M42-Mount adapters.

## C-Mount adapter Type 1

Product code	Supported models	Description	Optical filter
1068100	Goldeye G/CL-008, G/CL-032, G/CL-033	Adapter from M42 to C-Mount	Without optical filter support
1068200	Goldeye G/CL-034 TEC1	Adapter from M42 to C-Mount	Without optical filter support
1068800	Models with C-Mount adapter Type 1	Filter mounting set for Goldeye G/CL C-Mount adapter Type 1	Filter support including filter retaining ring, fixtures, tool

Table 192: C-Mount adapter Type 1 and product codes

## C-Mount adapter Type 2

These models are equipped with C-Mount adapter Type 2 by default: Goldeye G/CL-008 XSWIR 1.9/2.2 TEC2, -030 TEC1, -034 TEC2, -034 XSWIR 1.9/2.2 TEC2, and -130 TEC1.

No additional adapters or filter recesses are offered.

## F-Mount adapters

Product code	Supported models	Description	Optical filter
1068101	Goldeye G/CL-008, G/CL-032, G/CL-033	Adapter from M42 to F-Mount	Without optical filter support
1068201	Goldeye G/CL-034 TEC1	Adapter from M42 to F-Mount	Without optical filter support
1068801	Models with F-Mount adapter	Filter mounting set for Goldeye G/CL F-Mount adapter	Filter support including filter retaining ring, fixtures, tool

Table 193: F-Mount adapter and product codes

## M42-Mount adapters

Product code	Supported models	Description	Optical filter
1068103	Goldeye G/CL-008, G/CL-032, G/CL-033	Adapter from M42 to M42-Mount	Without optical filter support
1068203	Goldeye G/CL-034 TEC1	Adapter from M42 to M42-Mount	Without optical filter support
1068801	Models with M42-Mount adapter	Filter mounting set for Goldeye G/CL M42-Mount adapter	Filter support including filter retaining ring, fixtures, tool

Table 194: M42-Mount adapter and product codes

## Sensor and mount dimensions

Figure 52 shows a schematic view of dimensions between sensor surface, sensor cover glass, and front flange of the camera housing. Table 195 on page 211 shows the corresponding values by Goldeye model.

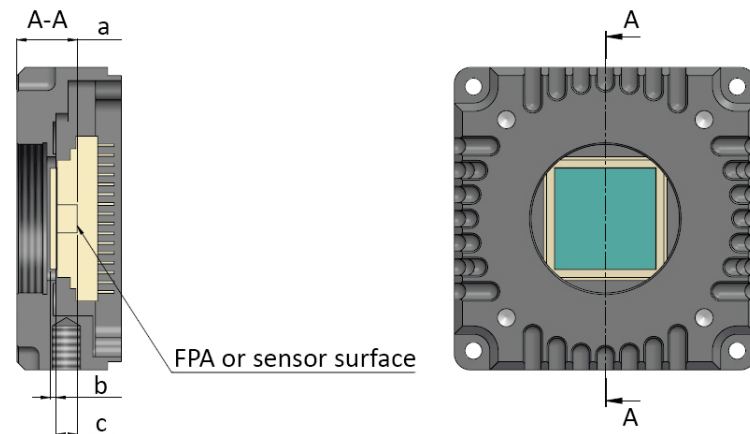

Figure 52: Sensor and mount dimensions (schematic view)

Goldeye model	C-Mount flange focal distance <sup>1</sup>	a	b	c
		Distance FPA <sup>2</sup> to front surface of front flange	Thickness of sensor cover glass	Distance FPA <sup>2</sup> to sensor cover glass
G/CL-008 TEC1	17.35 mm	8.48 mm	0.55 mm	0.17 mm
G/CL-008 Cool TEC1	17.35 mm	8.55 mm	0.55 mm	0.17 mm
G/CL-008 XSWIR TEC2	17.35 mm	8.05 mm	0.43 mm	0.82 mm
G/CL-030 TEC1	17.793 mm	10.97 mm	1.1 mm	3.83 mm
G/CL-032 TEC2	17.35 mm	8.48 mm	0.43 mm	0.47 mm
G/CL-032 Cool TEC2	17.35 mm	8.48 mm	0.43 mm	0.47 mm
G/CL-033 TEC1	17.59 mm	8.72 mm	1 mm	0.44 mm
G/CL-033 TECless	17.28 mm	8.41 mm	0.55 mm	0.75 mm
G/CL-034 TEC1	17.35 mm	9.58 mm	0.43 mm	2.42 mm
G/CL-034 TEC2	17.35 mm	8.05 mm	0.43 mm	0.82 mm
G/CL-034 XSWIR TEC2	17.35 mm	8.05 mm	0.43 mm	0.82 mm
G/CL-130 TEC1	17.793 mm	10.97 mm	1.1 mm	3.83 mm

<sup>1</sup>Without filter | <sup>2</sup>Active surface

Table 195: Sensor and mount dimensions by Goldeye model

## Sensor position accuracy

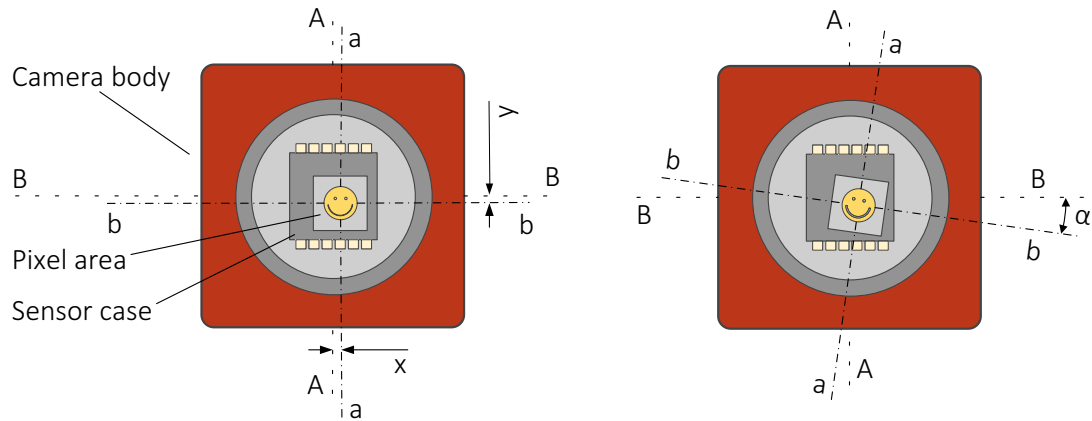

Figure 53: Sensor position accuracy (schematics)

The following table defines the manufacturing accuracy for sensor positioning.

Criteria	Subject	Properties
Alignment method		Optical alignment of the photosensitive sensor area into the camera front module (lens mount front flange)
Reference Points	Sensor	Center of the pixel area (photo sensitive cells)
	Camera	Center of the lens mount
Accuracy	x/y-axis <sup>1</sup>	±150 μm (sensor shift)
	z	+0 μm to -200 μm (optical back focal length)
	α <sup>1</sup>	±0.5 deg (sensor rotation as the deviation from the parallel to the camera bottom)

<sup>1</sup> X/Y- tolerances between the C-Mount hole and the pixel area may be higher.

Table 196: Sensor position accuracy criteria

## Camera feature availability

Goldeye G/CL cameras support a number of standard and extended features. The following tables compare the availability of selected features by model.



### Feature descriptions

Goldeye G/CL Features Reference: [www.alliedvision.com/en/support/technical-documentation/goldeye-gcl-documentation](http://www.alliedvision.com/en/support/technical-documentation/goldeye-gcl-documentation)

Image control	Supported models
Auto contrast	All
Auto exposure	All
Background correction	All
Binning	All
Black level	G/CL-030, G/CL-130
Decimation	G/CL-030, G/CL-130
DPC (defect pixel correction)	All
Look up table (LUT)	All
Multiple ROIs (regions of interest)	All G/CL-008 models, G/CL-030, all G/CL-034 models, G/CL-130
NUC (non-uniformity correction)	All
ROI (region of interest)	All
Ultra short exposure mode	G/CL-030, G/CL-130

Table 197: Image control features by Goldeye G/CL model

Camera control	Supported models
Acquisition frame rate	All
Bandwidth control (DeviceLinkThroughputLimit)	GigE models only
Event channel	All
Firmware update in the field	All
I/O and trigger control	All
Image chunk data	All
Stream hold	All
User sets	All

Table 198: Camera control features by Goldeye G/CL model

Temperature control	Supported models
Temperature management by TEC	All, except for TECless models
Temperature status indicator	All, except for TECless models

Table 199: Temperature control features by Goldeye G/CL model

# Lenses and filters



This chapter includes:

About this chapter .....	215
Optical vignetting with certain lenses .....	215
Focal length vs. field of view .....	216
Filter specifications .....	219

## About this chapter

This section presents tables that list selected fields of view (FOV) depending on sensor size, distance, and focal length of the lens.

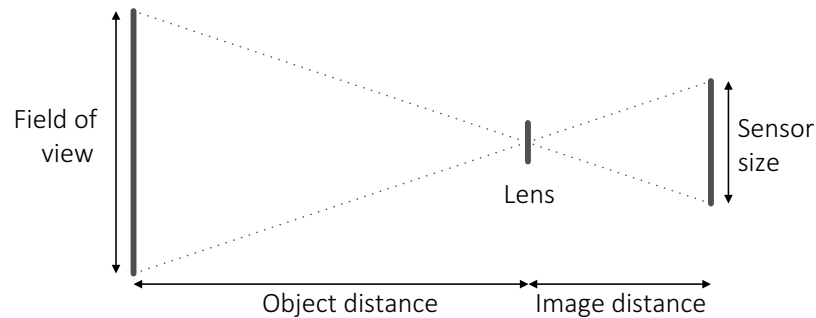

Figure 54: Parameters used in tables for focal length versus FOV

### Parameters in tables

The distance to the object is measured from the first principal plane of the lens to the object. For some lenses, manufacturers do not define the principal plane position. Production spread causes tolerances for all values, including actual focal lengths. Calculations apply for image reproduction without distortion. Therefore, values do not apply for fisheye lenses.

Please ask your Allied Vision Sales representative in case you need more information.

## Optical vignetting with certain lenses

Lenses with short focal lengths may show optical vignetting at the edges of the image. Microlenses on the sensor pixels can increase the effect.

For demanding applications, we suggest testing camera and lens to find a suitable setup. If you have questions, please contact your Allied Vision Sales representative.

## Focal length vs. field of view

### Goldeye G/CL-008 models

Values for Goldeye G/CL-008 cameras with 9.6 mm × 7.68 mm sensors (12.29 mm diagonal):

Focal length [mm]	Field of view (H × V [mm])	
	Object distance = 500 mm	Object distance = 1000 mm
8	590 × 472	1190 × 952
10	470 × 376	950 × 760
12	390 × 312	790 × 632
16	290 × 232	590 × 472
25	182 × 146	374 × 300
35	128 × 102	265 × 212
50	86 × 69	182 × 146

Table 200: Focal length versus field of view for Goldeye G/CL-008 cameras

### Goldeye G/CL-030 models

Values for Goldeye G/CL-030 cameras with 3.28 mm × 2.6 mm sensors (4.19 mm diagonal):

Focal length [mm]	Field of view (H × V [mm])	
	Object distance = 500 mm	Object distance = 1000 mm
6	270 × 214	543 × 431
8	202 × 160	407 × 322
10	161 × 127	325 × 257
12	133 × 106	270 × 214
16	99 × 79	202 × 160
25	62 × 49	128 × 101
35	44 × 35	90 × 72

Table 201: Focal length versus field of view for Goldeye G/CL-030 cameras



## Goldeye G/CL-032 models

Values for Goldeye G/CL-032 cameras with 15.9 mm × 12.7 mm sensors (20.35 mm diagonal):

Focal length [mm]	Field of view (H × V [mm])	
	Object distance = 500 mm	Object distance = 1000 mm
16	481 × 384	978 × 781
25	302 × 241	620 × 495
35	211 × 169	438 × 350
50	143 × 114	302 × 241
75	90 × 72	196 × 157
100	64 × 51	143 × 114

Table 202: Focal length versus field of view for Goldeye G/CL-032 cameras

## Goldeye G/CL-033 models

Values for Goldeye G/CL-033 cameras with 9.6 mm × 7.68 mm sensors (12.29 mm diagonal):

Focal length [mm]	Field of view (H × V [mm])	
	Object distance = 500 mm	Object distance = 1000 mm
8	590 × 472	1190 × 952
10	470 × 376	950 × 760
12	390 × 312	790 × 632
16	290 × 232	590 × 472
25	182 × 146	374 × 300
35	128 × 102	265 × 212
50	86 × 69	182 × 146

Table 203: Focal length versus field of view for Goldeye G/CL-033 cameras

## Goldeye G/CL-034 models

Values for Goldeye G/CL-034 cameras with 9.54 mm × 7.62 mm sensors (12.21 mm diagonal):

Focal length [mm]	Field of view (H × V [mm])	
	Object distance = 500 mm	Object distance = 1000 mm
8	587 × 469	1183 × 945
10	467 × 373	944 × 754
12	388 × 310	785 × 627
16	289 × 231	587 × 469
25	181 × 145	372 × 297
35	127 × 101	263 × 210
50	86 × 69	181 × 145

Table 204: Focal length versus field of view for Goldeye G/CL-034 cameras

## Goldeye G/CL-130 models

Values for Goldeye G/CL-130 cameras with 6.4 mm × 5.12 mm sensors (8.2 mm diagonal):

Focal length [mm]	Field of view (H × V [mm])	
	Object distance = 500 mm	Object distance = 1000 mm
6	527 × 422	1060 × 848
8	394 × 315	794 × 635
10	314 × 251	634 × 507
12	260 × 208	527 × 422
16	194 × 155	394 × 315
25	122 × 97	250 × 200
35	85 × 68	176 × 141

Table 205: Focal length versus field of view for Goldeye G/CL-130 cameras

# Filter specifications



## Available filters

This chapter informs about different filters that can be used with Goldeye G/CL cameras.

For **available filters**, see [Optical filters and accessories](#) on page 229.

The Modular Concept lists a selection of **standard options**:

[www.alliedvision.com/fileadmin/content/documents/products/cameras/various/modular-concept/ModularConcept\\_external.pdf](http://www.alliedvision.com/fileadmin/content/documents/products/cameras/various/modular-concept/ModularConcept_external.pdf)

Please contact your Allied Vision representative for **more options**:

[www.alliedvision.com/en/avt-locations/avt-distributors](http://www.alliedvision.com/en/avt-locations/avt-distributors)

## General terms explained

In general, these types of filters are used to filter visible and invisible wavelengths of various frequencies:

- **Bandpass filters** are translucent for a certain wavelength, rejecting all wavelengths above and below the defined range.
- **Longpass filters** are translucent from a certain wavelength onwards and for all wavelengths above it, thus rejecting all wavelengths below.
- **Visible cut-off filters** are a subset of longpass filters that prevent visible light from passing to the sensor.
- **Shortpass filters** are translucent up to a certain wavelength and for all wavelengths below, thereby rejecting all wavelengths above.
- **Notch** or **band reject filters** are translucent for all wavelengths above and below a defined range, thereby rejecting all wavelengths of that range. A Band Reject filter can be seen as the opposite of a Bandpass filter.

## Bandpass filters

The Goldeye responds to wavelengths from about 900 nm to 1700 nm. Using a bandpass filter, it is possible to restrict the complete bandwidth to a certain range of wavelengths. That way, only a certain wavelength band is transmitted, all others are rejected.

The describing characteristics of a bandpass filter are properties like optical density, or spectral profile. The main characteristics, however, are the center wavelength (CWL) together with the bandwidth (full width at half maximum, FWHM) being transmitted. Bandpass filters can cut the transmitted frequencies more or less sharply. Accordingly, the increase or decrease in gain at the edges of the translucent frequency band is more or less steep. This results in certain properties for each bandpass filter, that are defined by the following terms.

## Passband

The passband is the band of wavelengths that the filter allows to pass. Generally, the passband refers to the range of wavelengths between the **Cut-on** and **Cut-off** wavelengths. Therefore, most often the passband is described using the central wavelength and the FWHM.

## Stopband

The stopband is the range of wavelengths over which unwanted signals are attenuated. Bandpass filters have two stopbands, one above and one below the passband. As a rule, the end of the stopbands is not precisely defined.

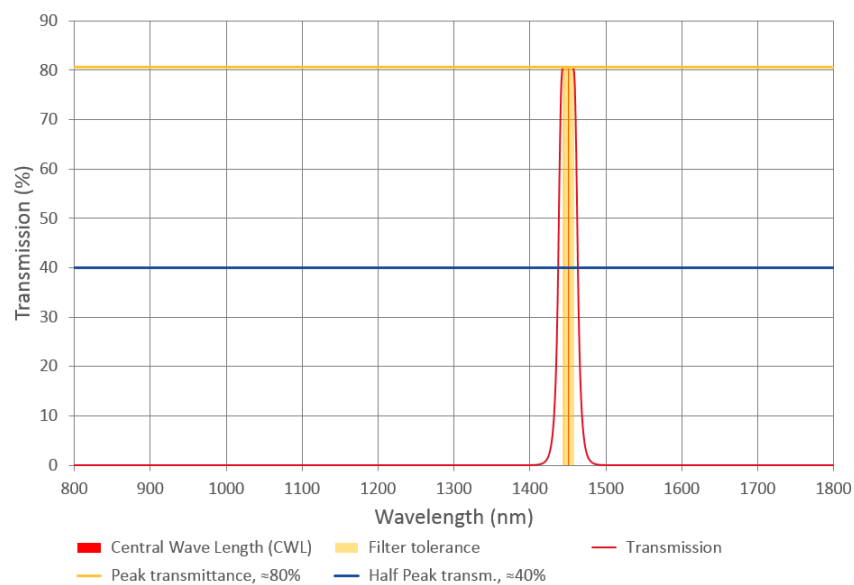

Figure 55: Example of a response curve of a bandpass water filter

## CWL (=central wavelength)

The wavelength at the center of the filter's passband. This wavelength is the arithmetical mean of the Cut-on and Cut-off wavelengths.

## Cut-on and Cut-off wavelength

The Cut-on wavelength is the wavelength within the transition slope from rejection to pass where the transmittance is at 50 percent of peak transmittance. The Cut-off wavelength is the wavelength within the transition slope from pass to rejection where the transmittance is at 50 percent of peak transmittance. The range between both wavelengths is called the **FWHM**.

## Peak Transmittance

Also referred to as filter **Transmission Rate**. The peak transmittance describes the maximum amount of light that a filter allows to pass. No filter allows 100 percent of the light to pass, however, good quality filters allow more light to pass through, thus their transmission rate is closer to 100 percent. Filters of lower quality appear darker, they transmit only slightly more than 50 percent of the light.

## Tolerance

The range of wavelengths within the passband, equally on both sides of the central wavelength, that provide transmission rates very close to the peak transmittance around the center wavelength.

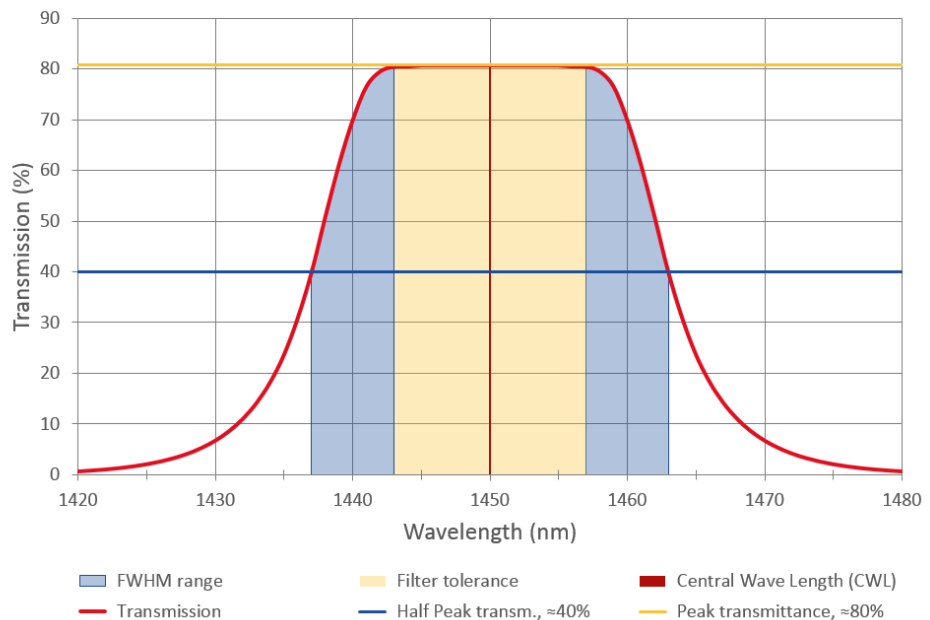

Figure 56: Detail of the water filter pictured in Figure 55, CWL = 1450 nm  $\pm$  7 nm, FWHM = 26.5 nm

## FWHM (Full Width at Half Maximum)

Also called **Half Bandwidth**. Defines the width of the passband of a bandpass filter. It is defined as the range of wavelengths on either side of the CWL where the transmission rate is one half of the peak transmittance or higher.

## Half Power Points

Points on both sides of the passband curve of a filter, with a transmission rate that is half of the peak transmittance; the range of wavelengths between these points is called the **FWHM**. The arithmetical mean of the wavelengths of these points is called the **CWL**. The half power points define the **Cut-on** and **Cut-off** wavelengths.

## Single and multi band filters

**Single band** filters provide only one passband.

**Multi band** filters provide two or more passbands that are separated by a rejection band.

## Bandpass filters 1450 nm (water filters)

As an example, the center wavelength of a water filter displayed in [Figure 56](#) is 1450 nm with a tolerance of  $\pm 7$  nm, and a FWHM bandwidth of 26.5 nm. The maximum transmission of the passband is around 80 percent. Therefore, the FWHM in this example is defined as the range of frequencies around the CWL where the transmission is 40 percent or above.



### **Bandpass filters 1450 nm assembled**

See [Bandpass filter 1450 nm \(water filter\)](#) on page 229.

# Accessories



This chapter includes:

Electrical connections .....	224
Power supplies .....	224
Ethernet adapters .....	226
Camera Link cables.....	226
12-pin Hirose I/O connectors and cables .....	227
Lens mount adapters .....	228
Optical filters and accessories .....	229
Heat sink set.....	230

## Electrical connections

In this section you find a selection of essential accessories to get your Goldeye camera up and running quickly.

These accessories are also listed in the appropriate places throughout this manual.

Allied Vision provides accessories to run and connect the Goldeye. To obtain an overview of all accessories available, go to the Allied Vision Accessories webpage.

## Power supplies

### Goldeye G/CL Industrial Design models

Use only with the following Goldeye models:

- G/CL-008 TEC1
- G/CL-030 TEC1
- G/CL-032 TEC1
- G/CL-033 TEC1 and G/CL-033 TECless
- G/CL-034 TEC1
- G/CL-130 TEC1

Product code	Description
13869	Power supply 12V DC 24W 12-Pin Hirose Desktop Power Supply 100-240V AC-> 12V 2A DC Hirose 12p without AC power cord

Table 206: Power supply for Goldeye standard models

### Goldeye G/CL Scientific Design models

Use only with the following Goldeye models (see [Industrial Design and Scientific Design](#) on page 34):

- G/CL-008 Cool TEC1
- G/CL-008 XSWIR 1.9 TEC2
- G/CL-008 XSWIR 2.2 TEC2
- G/CL-032 Cool TEC2
- G/CL-034 TEC2
- G/CL-034 XSWIR 1.9 TEC2
- G/CL-034 XSWIR 2.2 TEC2

Product code	Description
13867	Power supply 12V DC 24W 4-Pin Hirose Desktop Power Supply 100-240V AC-> 12V 2A DC Hirose 4-pin without AC power cord

Table 207: Power supply for Goldeye Scientific Design models



## AC supply cables for power supplies

Product code	Description
13865	AC power cable Length: <b>1.8</b> meters EU <-> C13 CEE 7/7 W90 <-> IEC320-C13 for use with IEC320-C14 socket, for power supply 13867 and 13869
13866	AC power cable Length: <b>1.8</b> meters US <-> C13 NEMA 5-15P straight <-> IEC320-C13 for use with IEC320-C14 socket, for power supply 13867 and 13869

Table 208: AC supply cables for power supplies

## Hirose 4-pin power cables for Goldeye Scientific Design models

See [Industrial Design and Scientific Design](#) on page 34.

Product code	Description
1068904	Power cable with Hirose 4-pin female connector to open end Length: <b>2.0</b> meters
1068905	Power cable with Hirose 4-pin female connector to open end Length: <b>3.0</b> meters
1068906	Power cable with Hirose 4-pin female connector to open end Length: <b>5.0</b> meters
1068907	Power cable with Hirose 4-pin female connector to open end Length: <b>10.0</b> meters

Table 209: Hirose 4-pin power cables for Goldeye Scientific Design models

## Ethernet adapters

Use Ethernet adapters with Goldeye G cameras.

Product code	Description
02-3003C	Standard adapter PCI-E Card, GigE, Intel CT, PCIe x1, 1 port EXPI9301CTBLK
02-3005A	Dual port adapter without PoE PCI-E Card, GigE, Intel Pro1000/PT, PCIe x4, 2 ports
12400	Dual port PoE adapter Adlink GIE72 PCIe4 GigE PoE+ Dual Port Host Controller
12401	Four port PoE adapter Adlink GIE74 PCIe8 GigE PoE+ Quad Port Host Controller

Table 210: Ethernet adapters

## Camera Link cables

Use Camera Link cables with Goldeye CL cameras.

### MDR-26 to SDR-26 cables

Product code	Description
9001030	Camera Link cable Length: <b>3.0</b> meters Up to 85 MHz, 8.4 mm, MDR-26 straight to SDR-26 straight
9001032	Camera Link cable Length: <b>5.0</b> meters Up to 85 MHz, 8.4 mm, MDR-26 straight to SDR-26 straight
9001036	Camera Link cable Length: <b>10.0</b> meters Up to 85 MHz, 11.0 mm, MDR-26 straight to SDR-26 straight

Table 211: Camera Link cables MDR to SDR

## SDR-26 to SDR-26 cables

Product code	Description
9001040	Camera Link cable Length: <b>3.0</b> meters 85 MHz, 8.4 mm, SDR-26 straight to SDR-26 straight
9001042	Camera Link cable Length: <b>5.0</b> meters 85 MHz, 8.4 mm, SDR-26 straight to SDR-26 straight
9001046	Camera Link cable Length: <b>10.0</b> meters 85 MHz, 11.0 mm, SDR-26 straight to SDR-26 straight

Table 212: Camera Link cables SDR to SDR

## 12-pin Hirose I/O connectors and cables

The connectors or cables available for Goldeye cameras are listed in [Table 213](#).

Use 12-pin Hirose connectors for both I/O signals and power supply with the following Goldeye models:

- G/CL-008 TEC1
- G/CL-030 TEC1
- G/CL-032 TEC1
- G/CL-033 TEC1, G/CL-033 TECless
- G/CL-034 TEC1
- G/CL-130 TEC1

Use 12-pin Hirose connectors only for I/O signals with the following Goldeye models:

- G/CL-008 Cool TEC1
- G/CL-008 XSWIR 1.9/2.2 TEC2
- G/CL-032 Cool TEC2
- G/CL-034 TEC2
- G/CL-034 XSWIR 1.9/2.2 TEC2

Product code	Description
K7600040	Connector Hirose 12-pin female (HR10A-10P-12S) straight
K7600044	Connector Hirose 12-pin female (HR10A-10LP-12S) angled
2814	I/O cable Length: <b>2.0</b> meters Power, Trigger 12-pin Hirose female to open end

Table 213: Hirose 12-pin I/O connectors and cables (sheet 1 of 2)

Product code	Description
2815	I/O cable Length: <b>3.0</b> meters Power, Trigger 12-pin Hirose female to open end
2817	I/O cable Length: <b>5.0</b> meters Power, Trigger 12-pin Hirose female to open end
2818	I/O cable Length: <b>10.0</b> meters Power, Trigger 12-pin Hirose female to open end
1068908	Trigger cable Length: <b>2.0</b> meters BNC to Hirose In1 LVTTL

Table 213: Hirose 12-pin I/O connectors and cables (sheet 2 of 2)

## Lens mount adapters

Separate lens adapters for various mounts are available for purchase from Allied Vision. These adapters fit into the M42-Mount of the camera front flange. For readily assembled mount adapters with special-purpose optical filter see [Table 216](#).

Product code	Description
1068100	Adapter from M42 to C-Mount without optical filter Goldeye G/CL-008, G/CL-032, G/CL-033
1068101	Adapter from M42 to F-Mount without optical filter Goldeye G/CL-008, G/CL-032, G/CL-033
1068103	Adapter from M42 to M42-Mount without optical filter Goldeye G/CL-008, G/CL-032, G/CL-033
1068200	Adapter from M42 to C-Mount without optical filter Goldeye G/CL-034
1068201	Adapter from M42 to F-Mount without optical filter Goldeye G/CL-034
1068203	Adapter from M42 to M42-Mount without optical filter Goldeye G/CL-034

Table 214: Mount adapters for Goldeye Cameras

## Optical filters and accessories



### NOTICE

#### Damage to optical filters

Optical filters can easily be scratched and damaged.  
Store away unused optical filters carefully.

## Filter mounting sets



#### Availability

Filter mounting sets are available for all Goldeye G/CL models  
**except for** G/CL-030 TEC1 and G/CL-130 TEC1.

Each optical filter mounting set consists of one filter retaining ring, fixtures, and a fixing tool.

Product code	Description
1068800	C-Mount adapter including filter retaining ring, fixtures, and tool
1068801	F-Mount adapter or M42-Mount adapter, including filter retaining ring, fixtures, and tool

Table 215: Filter mounting sets for Goldeye models

## Bandpass filter 1450 nm (water filter)



#### Availability

Readily assembled mount adapters are available for all Goldeye G/CL models,  
**except for** G/CL-030 TEC1 and G/CL-130 TEC1.

This bandpass filter has a CWL of 1450 nm and a tolerance of  $\pm 7$  nm.

The **readily assembled** mount adapters with bandpass filter that are listed in [Table 216](#) have a bandpass filter with a CWL of 1450 nm and FWHM bandwidth of 26.5 nm.

Product code	Goldeye models	Mounting set
1068140	G/CL-008, G/CL-032, G/CL-033	M42 to C-Mount with 1450 nm bandpass filter
1068141	G/CL-008, G/CL-032, G/CL-033	M42 to F-Mount with 1450 nm bandpass filter
1068143	G/CL-008, G/CL-032, G/CL-033	M42 to M42-Mount with 1450 nm bandpass filter
1068240	G/CL-034	M42 to C-Mount with 1450 nm bandpass filter
1068241	G/CL-034	M42 to F-Mount with 1450 nm bandpass filter
1068243	G/CL-034	M42 to M42-Mount with 1450 nm bandpass filter

Table 216: Bandpass filters 1450 nm mounting sets

## Filters with C-Mount adapter Type 2



### C-Mount adapters

See [Lens mount adapters by model](#) on page 208 for C-Mount adapters Type 1 and Type 2.

### Only for the following models:

Goldeye G/CL-008 XSWIR 1.9/2.2 TEC2, G/CL-030 TEC1, G/CL-034 TEC2, G/CL-034 XSWIR 1.9/2.2 TEC2, G/CL-130 TEC1

Product code	Description
1450	Bandpass filter BP 1450 nm $\varnothing$ 25.4 mm FWHM: 35 nm   tolerance: $\pm$ 10 nm
920	Longpass (visible cut-off) LP920-25.4 $\varnothing$ 25.4 mm

Table 217: Filter for Goldeye models with C-Mount adapter Type 2



### Filters for models with C-Mount adapter Type 2

For Bandpass filter BP 1450 and Longpass LP920, see “Spectral transmission of filters” in the Modular Concept at [www.alliedvision.com/fileadmin/content/documents/products/cameras/various/modular-concept/ModularConcept\\_external.pdf](http://www.alliedvision.com/fileadmin/content/documents/products/cameras/various/modular-concept/ModularConcept_external.pdf).

For other filters, please contact your Allied Vision representative for more options: [www.alliedvision.com/en/avt-locations/avt-distributors](http://www.alliedvision.com/en/avt-locations/avt-distributors)

## Heat sink set

To improve the cooling capability of the temperature-stabilized and TECless Goldeye models, a heat sink set is available that can be mounted to the camera by the customer. Up to four heat sinks can be fitted to one camera.

Product code	Description
1068300	Heat sink set for Goldeye G/CL cameras, including thermal interface pad, fixtures, and mounting tool

Table 218: Heat sink set for Goldeye models

# Installing the camera (GigE)



This chapter includes:

Touching hot cameras .....	232
Electrostatic discharge .....	232
Mounting the camera .....	232
Mounting the lens.....	235
Configuring the host computer .....	236
Connecting camera and host computer .....	239
Powering up the camera.....	239
Software for your Goldeye G camera .....	241
Acquiring a first image .....	242

## Touching hot cameras



### CAUTION

#### Risk of burns

A camera in operation can reach temperature levels which could cause burns.

- Wear protective gloves when you touch a camera that is heated up.
- Ensure proper cooling of the camera.
- See [Providing optimum heat dissipation](#) on page 42.

## Electrostatic discharge



### NOTICE

ESD is dangerous for electronic devices, especially when tools or hands get in contact with connectors. We recommend measures to avoid damage by ESD:

- Unpacking: Remove the camera from its anti-static packaging only when your body is grounded.
- Workplace: Use a static-safe workplace with static-dissipative mat and air ionization.
- Wrist strap: Wear a static-dissipative wrist strap to ground your body.
- Clothing: Wear ESD-protective clothing. Keep components away from your body and clothing. Even if you are wearing a wrist strap, your body is grounded but your clothes are not.

## Mounting the camera



### CAUTION

#### Injury by falling cameras or lenses

A falling camera or lens can cause injury.

- Ensure proper mounting of cameras and lenses, especially for dynamic applications.
- Mount cameras as described in the instructions.
- Use all mounting holes of a camera side.
- Always make sure the mounting threads are intact.
- Fasten screws with maximum torque, using the entire thread engagement. For less thread engagement, see [Adapting maximum torque values](#) on page 234.
- We recommend you to apply thread locking.
- Use a lens support for heavy lenses.



## Mounting Industrial Design models

See [Industrial Design and Scientific Design](#) on page 34.

Mounting holes for Goldeye Industrial Design

**Except for Goldeye Scientific Design**

M4 ↓6.0 ↓7.5

A=M4 | B=0 | C=6.0 | D=7.5

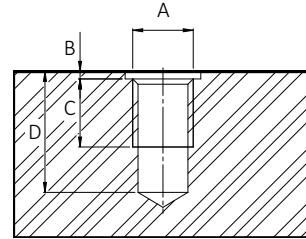

Figure 57: Mounting threads for Industrial Design models

**The maximum torque value applies only if the entire thread engagement is used.** For other values, see [Adapting maximum torque values](#) on page 234.

The camera can be mounted to horizontal or vertical bases, using

- 2 mounting threads for top and bottom mounting
- 4 mounting threads for lateral mounting

The backside has no mounting holes.

1. Mount the camera to the base using suitable M4 screws at 2.7 Nm maximum torque for a thread engagement (C) of 6 mm between screws and mounting threads, see [Figure 57](#). For details, see your model's technical drawings.
2. Continue with [Mounting the lens](#) on page 235.

## Mounting Scientific Design models

### Top, bottom, lateral mounting

See [Industrial Design and Scientific Design](#) on page 34.

Mounting holes for Goldeye Scientific Design

**Except for front mounting**

M4 ↓6.0 ↓8.0

A=M4 | B=0 | C=6.0 | D=8.0

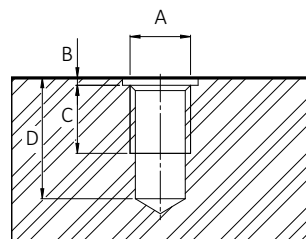

Figure 58: Mounting threads for Scientific Design models

**The maximum torque value applies only if the entire thread engagement is used.** For other values, see [Adapting maximum torque values](#) on page 234.

The camera can be mounted to horizontal or vertical bases, using 4 mounting threads on each side of the camera, except for the back side.

1. Mount the camera to the base using suitable M4 screws at 2.7 Nm maximum torque for a thread engagement (C) of 6 mm between screws and mounting threads, see [Figure 58](#). For details, see your model's technical drawings.
2. Continue with [Mounting the lens](#) on page 235.

## Front mounting for all models

Mounting holes for all Goldeye models

### Front mounting only

M4 ↓7.0 ↓7.0

A=M4 | B=0 | C=7.0 | D=7.0

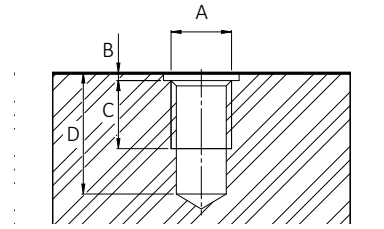

Figure 59: Front mounting threads for all Goldeye models

**The maximum torque value applies only if the entire thread engagement is used.** For other values, see [Adapting maximum torque values](#) on page 234.

The camera can be mounted to horizontal or vertical bases, using four mounting threads on each side of the camera, except for the back side.

1. Mount the camera to the base using suitable M4 screws at 3.4 Nm maximum torque for a thread engagement (C) of 7 mm between screws and mounting threads, see [Figure 59](#). For details, see your model's technical drawings.
2. Continue with [Mounting the lens](#) on page 235.

## Adapting maximum torque values

The total bolt length composes of the mounting holes length and the height of your mounting base.

For using less than the stated length of thread engagement, calculate maximum torque as follows:

$$\frac{\text{Current length of thread engagement}}{\text{Length of thread engagement in table}} \times \text{Torque in table} = \text{Current torque}$$

This example relates to Goldeye front mounting for a length of thread engagement of **6 mm** instead of 7 mm: **6 mm / 7 mm × 3.4 Nm = 2.9 Nm**

Model group	Thread position	Thread type	Total protrusion	Length of thread engagement	Maximum torque
All models	Front mounting	M4	7 mm	7 mm	3.4 Nm
	Front mounting	M4	7 mm	<b>6 mm</b>	<b>2.9 Nm</b>

Table 219: Adjusting maximum torque values

To ensure that the bolts do not become loose over time, we recommend you to use means for securing bolts, such as screw locking varnish.

## 1/4" -20 UNC mounting thread

To attach the camera to the common mounting plate of tripods used in photography, a 1/4"-20 UNC mounting thread is located on the camera bottom.

## Mounting the lens



### CAUTION

#### Injury by falling cameras or lenses

A falling camera or lens can cause injury.

- Ensure proper mounting of cameras and lenses, especially for dynamic applications.
- Mount cameras as described in the instructions.
- Use a lens support for heavy lenses.



### CAUTION

#### Risk of cuts by sharp edges of lens mounts

The threads of the lens mount can have sharp edges.

Be careful when mounting or unmounting lenses.



### NOTICE

#### Damage to the sensor and optical surfaces by dirt and scratches

The image sensor is the most valuable component in Goldeye cameras. The sensor can be permanently damaged if you try to remove dirt from the sensor surface with unsuitable means or if the sensor gets into contact with aggressive agents.

To protect the sensor and the optical path from dirt and droplets, provide the following conditions:

- Dust-free environment
- Low relative humidity
- No condensation.



### NOTICE

#### Damage to the camera by improper cleaning

Goldeye G/CL cameras do not need additional cleaning. Cameras are cleaned before shipping. Incorrect cleaning can damage the sensor or the optical filter.

- Never clean the sensor or the optical filter.
- Protect the optical filter and the sensor from dirt. (Dirt becomes more visible the closer it gets to the sensor.)
- Keep the back lens clean.
- Protect the lens mount by a keep or a lens. Otherwise, hold the camera with the lens mount facing the ground to keep dirt out of the lens mount.
- If you must clean the sensor or filter yourself, see [Cleaning optical components](#) on page 329.

**NOTICE****Damage to the sensor by focused light and excessive radiation**

Protect the sensor from focused sunlight, UV light, lasers, and X-rays.

See [Focal length vs. field of view](#) on page 211 to decide on the focal length of the lens for your application.

**Suitable lenses**

For information on available lenses and accessories for your camera, see [www.alliedvision.com/en/products/accessories](http://www.alliedvision.com/en/products/accessories) or contact your Allied Vision Sales representative.

**Available lens mounts for Goldeye cameras**

For more information on lens mount options, such as C-Mount, F-Mount, and M42-Mount, see the Modular Concept at [www.alliedvision.com/en/support/technical-documentation/goldeye-gcl-documentation](http://www.alliedvision.com/en/support/technical-documentation/goldeye-gcl-documentation).

## Configuring the host computer

Goldeye G cameras can operate on 100 Megabit or Gigabit speed NICs. To reach the maximum camera frame rate, a Gigabit speed NIC with jumbo packet support is required.

If your host computer has an available Ethernet port, this can be used with your Goldeye G camera. We recommend that your camera system uses a dedicated Ethernet port not shared with internet or local area networks. If more ports are needed, or your existing NIC is unable to operate at Gigabit Ethernet speeds, installing additional hardware may be required.

- For desktop systems, install a PCI Express bus NIC.
- For laptops, use an expansion slot via a Gigabit Ethernet Express card.

Usage on mixed-use networks (with printers, internet or email, and other devices) is possible but may impact camera performance, for example, frame rate. Check with your IT administrator if required for network configuration.

For a list of Ethernet adapters available for purchase from Allied Vision, please contact Allied Vision sales representative or your local Allied Vision distribution partner.

**Compatible interface slot**

Verify that there is an available and compatible interface slot on the host computer before purchasing the desired NIC.

## Installing the NIC driver

Install the network card driver from your network card manufacturer. If no installation application is provided, update the driver manually.

### To update the driver manually

1. Click the **Start** icon and select **Control Panel** in the menu.
2. Click **View by Large Icons** and select **Device Manager** in the list.
3. Under **Network Adapters**, locate the Ethernet NIC, right-click the entry, and select **Update Driver Software** in the menu.
4. Select the **Search automatically for updated driver software** or **Browse my computer for driver software**.
5. Click **Close** after the driver has been installed.

## IP settings

After the initial NIC hardware installation, connect the NIC directly to the camera. The default configuration assigns an IP address automatically using the LLA (Link-Local Address) range of 169.254.xxx.xxx or an address defined by the DHCP (Dynamic Host Configuration Protocol) server, if present. This setup is a typical solution for single-camera operation or multiple cameras connected to the same NIC.

If you are going to operate multiple cameras on different networks, you can use the following configuration as a template.

All network devices (such as NICs, hubs or GigE cameras) require unique IP addresses. But connected devices must share the same address space. In the example shown in [Table 220](#), 3 cameras are connected to a common host PC, using 2 separate NICs. The address space for NIC 1 is 192.168.**100**, for NIC 2 it is 192.168.**101**:

Device	IP address	Subnet mask	Default gateway
NIC 1	192.168.100.1	255.255.255.0	Blank
Camera 1 connected to NIC 1	192.168.100.2	255.255.255.0	Blank
NIC 2	192.168.101.1	255.255.255.0	Blank
Camera 2 connected to NIC 2	192.168.101.2	255.255.255.0	Blank
Camera 3 connected to NIC 2	192.168.101.3	255.255.255.0	Blank

*Table 220: Static IP addresses for NICs and connected cameras*

## Optimizing system performance

The NIC should be adjusted to improve system performance when using a GigE Vision camera. This performance is related to minimizing CPU usage and dropped or resent packets.

Edit the NIC driver properties according to the values in the following table. The names and availability of the properties listed may vary depending on NIC manufacturer and model.

Property	Value
Packet size or maximum transmission unit	8228 bytes or larger
Interrupt moderation	Enable
Interrupt moderation rate	Extreme
Receive buffers	Maximum value configurable
Transmit buffers	256 bytes

*Table 221: Network interface card driver settings*

### Default packet size

The default packet size of Goldeye G cameras is 8228 bytes. The host NIC needs to support a packet size of equal or larger size to stream from the camera.

### NIC settings

The NIC settings may also vary depending on your system configuration and the NIC manufacturer.

For desktop systems, use a PCI Express bus NIC. For laptops, use an expansion slot via an ExpressCard®.

## Enabling jumbo packets

The properties listed for the NIC may include either **Jumbo Packet** or **Jumbo Frames** depending on the manufacturer. If neither is listed under properties, your network card may not support this feature. You must use a NIC that supports Jumbo Frames or Jumbo Packets.

### To enable jumbo packets

1. Click the **Start** icon and select **Control Panel** in the menu.
2. Click **View by Large Icons** and select **Device Manager** in the list.
3. Under **Network Adapters**, locate the Ethernet NIC, right-click the entry, and select **Properties** in the menu.
4. Select the **Advanced** tab.
5. Select the property **Jumbo Packet** and set the value to 9014 Bytes.
6. Click **OK** to save the settings.

**Support by various Gigabit Ethernet cards**

The settings list in the advanced adapter settings may vary between various types and brands of Gigabit Ethernet network cards (NICs). Common expressions are Jumbo Frames or Jumbo Packet.

If Jumbo Frames or Jumbo Packet does not appear in this list, your NIC may not support it. Without this capability, you may not be able to achieve the full performance of the camera. Higher frame rates can increase the power consumption. See [Specifications \(GigE models\)](#) on page 51 for details.

## Connecting camera and host computer

After you have installed **Vimba Viewer** or a third-party application to your host computer, connect your Goldeye G camera via a CAT5e or higher rated Ethernet cable to connect the camera to the NIC. Crossover cabling is not required but does work. The camera has circuitry to determine if a crossover cable is being used.

**Avoiding dropped frames**

Unsuitable GigE cables may not sustain peak interface bandwidth; leading to lost connectivity or dropped frames coming from the camera.

Use CAT5e or higher rated Ethernet cables.

If your camera is not PoE powered, connect the Hirose cable to power the camera. Goldeye G cameras are GigE Vision v1.2 compliant. This means they are compatible with third-party software that offers a GigE Vision driver.

## Powering up the camera

A camera power adapter for each Goldeye G camera is available from Allied Vision. See the Specifications chapter for connector definition and voltage specifications.

**NOTICE****Damage to the camera by unsuitable power supplies**

- Verify all external connections in terms of voltage levels, power requirements, voltage polarity before powering the device.
- Use only DC power supplies with insulated housings.
- **PoE+** for G-008 XSWIR TEC2, G-032 Cool TEC2, G-034 TEC2, G-034 XSWIR TEC2 models: IEEE 802.3at Type 2 Class 4 compliant PoE power sourcing equipment devices such as switches, injectors, or NICs
- **PoE** for all other Goldeye models: IEEE 802.3at Type 1 Class 0 compliant PoE power sourcing equipment devices such as switches, injectors, or NICs



#### Available power supplies by Allied Vision

The following power supplies and power cables are available:

- 13867 Desktop power supply Goldeye G/CL Scientific Design
- 13869 Desktop power supply Goldeye G Industrial Design
- 13866 AC power cable, 1.8 m, US to C13
- 13865 AC power cable, 1.8 m, EU to C13

See [Power supplies](#) on page 224.



#### NOTICE

#### Damage to the camera by exceeding the specified environmental conditions

- Operate Goldeye cameras only under conditions defined in [Specifications \(GigE models\)](#) on page 51.
- Ensure to maintain the operating temperature specified in [Specifications \(GigE models\)](#) on page 51.
- For heat dissipation, see [Providing optimum heat dissipation](#) on page 42.



#### Maximum length of I/O cables

The camera is not intended to be connected to a DC distribution network. The maximum length for I/O cables must not exceed 30 meters.

To power up the camera, plug the 12-pin Hirose connector into the camera and wait for the boot phase to complete. For Scientific Design models, use the 4-pin Hirose connector. The boot phase is indicated by a steady flashing of the Ethernet status LEDs.

## Hardware Selection

Cameras powered by both the Hirose I/O port and the Gigabit Ethernet port use the power provided by Hirose I/O port only.

## Powering the camera via PoE

Note the following when using PoE accessories with PoE-capable GigE cameras:

- **PoE+** for G-008 XSWIR TEC2, G-032 Cool TEC2, G-034 TEC2, G-034 XSWIR TEC2 models: IEEE 802.3at Type 2 Class 4 compliant PoE power sourcing equipment devices such as switches, injectors, or NICs
- **PoE** for all other Goldeye models: IEEE 802.3at Type 1 Class 0 compliant PoE power sourcing equipment devices such as switches, injectors, or NICs
- Ensure that your PSE provides data over all four pairs.
- If the PSE uses only two out of four pairs for data, operation is limited to 10/100 Mbps. This translates to lower frame rates.
- If the PSE uses all four pairs for data, operation is in Gigabit (1000 Mbps) mode. Therefore, allowing you to achieve the maximum possible frame rate.



# Software for your Goldeye G camera

Goldeye G cameras work with the following software options:

- **Vimba Viewer** or **Vimba SDK**
- Third-party software solutions

## Allied Vision software

Software packages provided by Allied Vision contain such as:

- Drivers
- SDK for camera control and image acquisition
- Examples based on the provided APIs of the SDK
- Documentation and release notes
- Viewer application to operate and configure the cameras

**Vimba** is Allied Vision's GenICam-based SDK with transport layers for all Allied Vision cameras with GigE Vision, USB3 Vision, IEEE 1394, and Camera Link (CL) interface. **Vimba** runs on Windows, Linux, and Linux for ARM. You can port your source code from Windows to Linux or cross-compile from a Linux PC to an embedded system.

**Vimba** provides APIs for C, C++, and .NET. Users who quickly want to develop a straightforward application love the simplicity of the C API or the .NET API.

Advanced users with high demands appreciate the C++ API, which is designed as a highly efficient and sophisticated API for advanced object-oriented programming including the STL (standard template library), shared pointers, and interface classes.

**Vimba** includes programming examples in C, C++, and C# and an extensive user documentation.



### Vimba download

Download **Vimba SDK** from [www.alliedvision.com/en/products/software](http://www.alliedvision.com/en/products/software). After installing, documentation is located under `\Program Files\Allied Vision\Vimba`.

## Third-party software

Above software provided by Allied Vision, other GigE Vision standard compliant third-party software options are available. In general, third-party software provides increased functionality such as image processing and video recording.

GenICam-based third-party software automatically connects with the transport layers of **Vimba**. Additionally, **Vimba** includes the **Cognex Adapter** for **VisionPro**.

## Acquiring a first image

After configuring the host PC, the camera parameters must be set to establish the connection with best performance. After that, launch the camera in **Vimba Viewer**:

1. Power up the camera. Booting has been finished when the Ethernet Status LEDs stops blinking.
2. Launch **Vimba Viewer**. The **Detected Cameras** list appears after a few seconds, depending on the number of cameras connected to the PC.
3. Select your camera from **Detected Cameras** list. A new camera window opens.

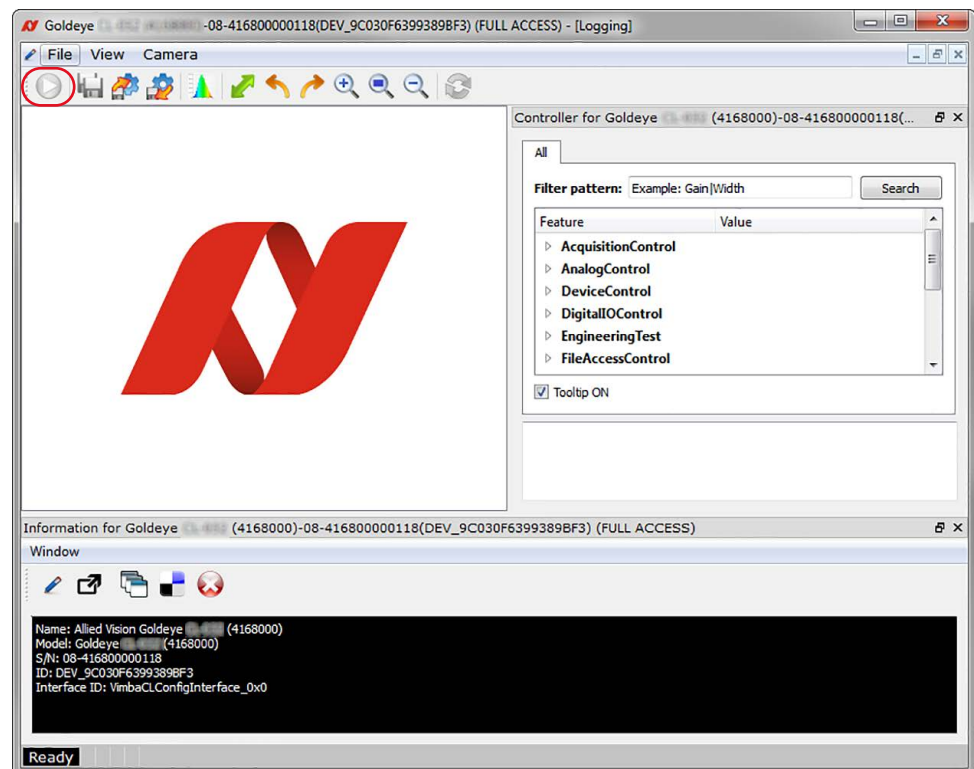

Figure 60: Vimba Viewer

To start continuous image acquisition with default camera settings, click the **freerun** button in the viewer toolbar. To stop the acquisition, click it again.

## Is the camera powered?

If you cannot reach the camera, check the GigE status LED at the GigE port on the backside of the camera. Once the camera is booted, the green LED remains active as long as the camera is connected to power. See [GigE status LEDs](#) on page 271 for details.

# Installing the camera (CL)



This chapter includes:

Touching hot cameras .....	244
Electrostatic discharge .....	244
Mounting the camera .....	244
Mounting the lens.....	247
Installing PC hardware and software .....	248
Connecting camera and host computer .....	249
Powering up the camera.....	250
Camera control and image viewing .....	251
Troubleshooting .....	258

## Touching hot cameras



### CAUTION

#### Risk of burns

A camera in operation can reach temperature levels which could cause burns.

- Wear protective gloves when you touch a camera that is heated up.
- Ensure proper cooling of the camera.
- See [Providing optimum heat dissipation](#) on page 42.

## Electrostatic discharge



### NOTICE

ESD is dangerous for electronic devices, especially when tools or hands get in contact with connectors. We recommend measures to avoid damage by ESD:

- Unpacking: Remove the camera from its anti-static packaging only when your body is grounded.
- Workplace: Use a static-safe workplace with static-dissipative mat and air ionization.
- Wrist strap: Wear a static-dissipative wrist strap to ground your body.
- Clothing: Wear ESD-protective clothing. Keep components away from your body and clothing. Even if you are wearing a wrist strap, your body is grounded but your clothes are not.

## Mounting the camera



### CAUTION

#### Injury by falling cameras or lenses

A falling camera or lens can cause injury.

- Ensure proper mounting of cameras and lenses, especially for dynamic applications.
- Mount cameras as described in the instructions.
- Use all mounting holes of a camera side.
- Always make sure the mounting threads are intact.
- Fasten screws with maximum torque, using the entire thread engagement. For less thread engagement, see [Adapting maximum torque values](#) on page 246.
- We recommend you to apply thread locking.
- Use a lens support for heavy lenses.

## Mounting Industrial Design models

(See [Industrial Design and Scientific Design](#) on page 34.)

Mounting holes for Goldeye Industrial Design

**Except for Goldeye Scientific Design**

M4 ↓6.0 ↓7.5

A=M4 | B=0 | C=6.0 | D=7.5

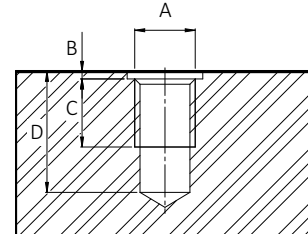

Figure 61: Mounting threads for Industrial Design models

**The maximum torque value applies only if the entire thread engagement is used.** For other values, see [Adapting maximum torque values](#) on page 246.

The camera can be mounted to horizontal or vertical bases, using

- 2 mounting threads for top and bottom mounting
- 4 mounting threads for lateral mounting

The backside has no mounting holes.

1. Mount the camera to the base using suitable M4 screws at 2.7 Nm maximum torque for a thread engagement (C) of 6 mm between screws and mounting threads, see [Figure 61](#). For details, see your model's technical drawings.
2. Continue with [Mounting the lens](#) on page 247.

## Mounting Scientific Design models

(See [Industrial Design and Scientific Design](#) on page 34.)

### Top, bottom, lateral mounting

Mounting holes for Goldeye Scientific Design

**Except for front mounting**

M4 ↓6.0 ↓8.0

A=M4 | B=0 | C=6.0 | D=8.0

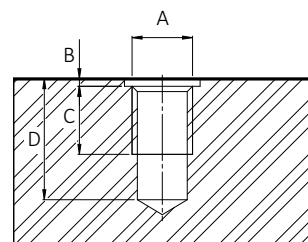

Figure 62: Mounting threads for Scientific Design models

**The maximum torque value applies only if the entire thread engagement is used.** For other values, see [Adapting maximum torque values](#) on page 246.

The camera can be mounted to horizontal or vertical bases, using 4 mounting threads on each side of the camera, except for the back side.

1. Mount the camera to the base using suitable M4 screws at 2.7 Nm maximum torque for a thread engagement (C) of 6 mm between screws and mounting threads, see [Figure 62](#). For details, see your model's technical drawings.
2. Continue with [Mounting the lens](#) on page 247.

## Front mounting for all models

Mounting holes for all Goldeye models

### Front mounting only

M4 ↓7.0 ↓7.0

A=M4 | B=0 | C=7.0 | D=7.0

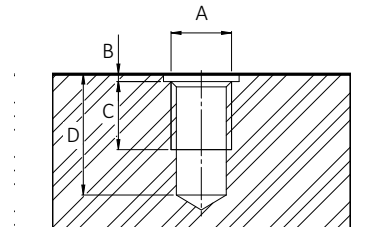

Figure 63: Front mounting threads for all Goldeye models

**The maximum torque value applies only if the entire thread engagement is used.** For other values, see [Adapting maximum torque values](#) on page 246.

The camera can be mounted to horizontal or vertical bases, using four mounting threads on each side of the camera, except for the back side.

1. Mount the camera to the base using suitable M4 screws at 3.4 Nm maximum torque for a thread engagement (C) of 7 mm between screws and mounting threads, see [Figure 63](#). For details, see your model's technical drawings.
2. Continue with [Mounting the lens](#) on page 247.

## Adapting maximum torque values

The total bolt length composes of the mounting holes length and the height of your mounting base.

For using less than the stated length of thread engagement, calculate maximum torque as follows:

$$\frac{\text{Current length of thread engagement}}{\text{Length of thread engagement in table}} \times \text{Torque in table} = \text{Current torque}$$

This example relates to Goldeye front mounting for a length of thread engagement of **6 mm** instead of 7 mm:

$$6 \text{ mm} / 7 \text{ mm} \times 3.4 \text{ Nm} = \mathbf{2.9 \text{ Nm}}$$

Model group	Thread position	Thread type	Total protrusion	Length of thread engagement	Maximum torque
All models	Front mounting	M4	7 mm	7 mm	3.4 Nm
	Front mounting	M4	7 mm	<b>6 mm</b>	<b>2.9 Nm</b>

Table 222: Adjusting maximum torque values

To ensure that the bolts do not become loose over time, we recommend you to use means for securing bolts, such as screw locking varnish.

## 1/4" -20 UNC mounting thread

To attach the camera to the common mounting plate of tripods used in photography, a 1/4"-20 UNC mounting thread is located on the camera bottom.

## Mounting the lens



### CAUTION

#### Injury by falling cameras or lenses

A falling camera or lens can cause injury.

- Ensure proper mounting of cameras and lenses, especially for dynamic applications.
- Mount cameras as described in the instructions.
- Use a lens support for heavy lenses.



### CAUTION

#### Risk of cuts by sharp edges of lens mounts

The threads of the lens mount can have sharp edges.

Be careful when mounting or unmounting lenses.



### NOTICE

#### Damage to the sensor and optical surfaces by dirt and scratches

The image sensor is the most valuable component in Goldeye cameras. The sensor can be permanently damaged if you try to remove dirt from the sensor surface with unsuitable means or if the sensor gets into contact with aggressive agents.

To protect the sensor and the optical path from dirt and droplets, provide the following conditions:

- Dust-free environment
- Low relative humidity
- No condensation.



### NOTICE

#### Damage to the camera by improper cleaning

Goldeye G/CL cameras do not need additional cleaning. Cameras are cleaned before shipping. Incorrect cleaning can damage the sensor or the optical filter.

- Never clean the sensor or the optical filter.
- Protect the optical filter and the sensor from dirt. (Dirt becomes more visible the closer it gets to the sensor.)
- Keep the back lens clean.
- Protect the lens mount by a keep or a lens. Otherwise, hold the camera with the lens mount facing the ground to keep dirt out of the lens mount.
- If you must clean the sensor or filter yourself, see [Cleaning optical components](#) on page 329.

**NOTICE****Damage to the sensor by focused light and excessive radiation**

Protect the sensor from focused sunlight, UV light, lasers, and X-rays.

See [Focal length vs. field of view](#) on page 211 to decide on the focal length of the lens for your application.

**Suitable lenses**

For information on available lenses and accessories for your camera, see [www.alliedvision.com/en/products/accessories](http://www.alliedvision.com/en/products/accessories) or contact your Allied Vision Sales representative.

**Available lens mounts for Goldeye cameras**

For more information on lens mount options, such as C-Mount, F-Mount, and M42-Mount, see the Modular Concept at [www.alliedvision.com/en/support/technical-documentation/goldeye-gcl-documentation](http://www.alliedvision.com/en/support/technical-documentation/goldeye-gcl-documentation).

## Installing PC hardware and software

### Frame grabbers

Almost every frame grabber compatible to Camera Link Base can be used to operate a Goldeye CL camera.

**Application Note: Usage of frame grabbers with Goldeye CL cameras**

Refer to this application note for detailed requirements:  
[www.alliedvision.com/fileadmin/content/documents/products/cameras/Goldeye\\_2/appnote/Goldeye-Framegrabber\\_AppNote\\_en.pdf](http://www.alliedvision.com/fileadmin/content/documents/products/cameras/Goldeye_2/appnote/Goldeye-Framegrabber_AppNote_en.pdf).

### Installing a frame grabber

For the installation of a frame grabber, the computer must meet the minimum system requirements of the frame grabber.

Find the requirements in the technical manual of the frame grabber.

Refer also to the frame grabber installation manual provided by the manufacturer regarding installation details.



## Installing frame grabber software

Read the frame grabber software installation guide provided by the frame grabber manufacturer.



### More information about frame grabbers:

For more information about compatibility of various frame grabber models and system installation, refer to the application note Usage of Frame grabbers with Goldeye CL Cameras at: [www.alliedvision.com/en/support/technical-documentation/goldeye-gcl-documentation](http://www.alliedvision.com/en/support/technical-documentation/goldeye-gcl-documentation).

## Installing camera software

This section presents instructions for software installation specific to Windows 7. Goldeye CL cameras can be operated under later versions of Windows as well. Allied Vision offers **Vimba** as the main SDK for its CL cameras.

To install the **Vimba SDK** plus corresponding **Vimba Viewer**, read [Installing Vimba Viewer on Windows on page 249](#).

Note that there is no Linux support for Camera Link with **Vimba**.



### Frame grabber configuration files

Some frame grabber applications use configuration files for a certain camera. If you need configuration files, please contact support at [www.alliedvision.com/en/about-us/contact-us/technical-support-repair-/rma](http://www.alliedvision.com/en/about-us/contact-us/technical-support-repair-/rma).

## Installing Vimba Viewer on Windows

You can install the **Vimba Viewer** on Windows 7, Windows 8.1, and Windows 10. To install the **Vimba Viewer** on Windows, follow these steps:

- Step 1: To start the installation, run the corresponding installer.
- Step 2: Select an installation level suitable for you.
- Step 3: Click **Start**. The installer will guide you through the installation process.

# Connecting camera and host computer

After you have installed **Vimba Viewer** or a third-party application to your host computer, connect your Goldeye CL camera via Camera Link cable with an SDR-26 connector for the camera side.

For information on the required connector type for the frame grabber (MDR-26 or SDR-26), refer to the frame grabber manual.



### Supported frame grabbers

You can find recommendations in the Frame Grabbers for Goldeye CL Cameras application note at [www.alliedvision.com/en/support/technical-documentation/goldeye-gcl-documentation](http://www.alliedvision.com/en/support/technical-documentation/goldeye-gcl-documentation).

Goldeye CL cameras work with the following software options:

- **Vimba Viewer** or **Vimba SDK**
- Third-party software solutions

To acquire images, the frame grabber SDK must be used.

## Powering up the camera



### NOTICE

#### **Damage to the camera and connected peripherals by high inrush current**

Camera Link does not support Hot Plugging, such as GigE or USB interfaces. Therefore, Goldeye CL cameras and the connected peripherals can be damaged if they are connected or disconnected improperly.

Always connect Goldeye CL cameras in the following order:

1. Connect the Camera Link cable.
2. Connect the power supply. Use only power supplies offered by Allied vision or ensure that third party equipment fulfills to the power specifications of your Goldeye CL model.

Consequently, disconnect Goldeye CL in the following order:

1. Disconnect the power supply.
2. Disconnect the Camera Link cable.



### NOTICE

#### **Damage to the camera by unsuitable power supplies**

- Verify all external connections in terms of voltage levels, power requirements, voltage polarity before powering the device.
- Use only DC power supplies with insulated housings.



#### **Available power supplies by Allied Vision**

The following power supplies and power cables are available:

- 13867 Desktop power supply Goldeye G/CL Scientific Design
- 13869 Desktop power supply Goldeye CL Industrial Design
- 13866 AC power cable, 1.8 m, US to C13
- 13865 AC power cable, 1.8 m, EU to C13

See [Power supplies](#) on page 224.

**NOTICE****Damage to the camera by exceeding the specified environmental conditions**

- Operate Goldeye cameras only under conditions defined in [Specifications \(GigE models\)](#) on page 51.
- Ensure to maintain the operating temperature specified in [Specifications \(GigE models\)](#) on page 51.
- For heat dissipation, see [Providing optimum heat dissipation](#) on page 42.

**Maximum length of I/O cables**

The camera is not intended to be connected to a DC distribution network. The maximum length for I/O cables must not exceed 30 meters.

The boot phase is indicated by a steady flashing of the Camera Link status LED.

## Camera control and image viewing

### Configuring your camera

After the host PC is configured, it is necessary to configure the parameters in the camera to establish the connection with best performance.

### Allied Vision software

Allied Vision software packages contain the following components:

- Drivers
- SDK for camera control and image acquisition
- Examples based on the provided APIs of the SDK
- Documentation and release notes
- Viewer application to operate and configure the cameras

**Vimba** is Allied Vision's GenICam-based SDK with transport layers for all Allied Vision cameras with GigE Vision, USB3 Vision, IEEE 1394, and Camera Link interface. **Vimba** runs on Windows, Linux, and Linux for ARM. You can port your source code from Windows to Linux or cross-compile from a Linux PC to an embedded system.

**Vimba** provides APIs for C, C++, and .NET. Users who quickly want to develop a straightforward application love the simplicity of the C API or the .NET API.

Advanced users with high demands appreciate the C++ API, which is designed as a highly efficient and sophisticated API for advanced object-oriented programming including the STL (standard template library), shared pointers, and interface classes.

**Vimba** includes programming examples in C, C++, and C# and an extensive user documentation.



### Vimba Viewer documentation

**Vimba Viewer** documentation is included with the software download. After **Vimba Viewer** is installed on your host computer, documentation is located under `\Program Files\Allied Vision\Vimba_[version]`.

## Third-party software

In addition to the software provided by Allied Vision, there are numerous GigE Vision standard compliant third-party software options available. In general, third-party software provides increased functionality such as image processing and video recording.

GenICam-based third-party software automatically connects with **Vimba's** transport layers. Additionally, **Vimba** includes the **Cognex Adapter** for **VisionPro**.

## Vimba with frame grabber specific viewer

### Overview

**Vimba** offers a GenTL compatible configuration transport layer to access a GenCP compatible Camera Link camera. This transport layer offers access to all camera features and is used to setup and control a camera. **Vimba Viewer** is used as control application only. Images of the camera are grabbed via the viewer application that comes with the frame grabber software installation. The following figure shows the corresponding block diagram.

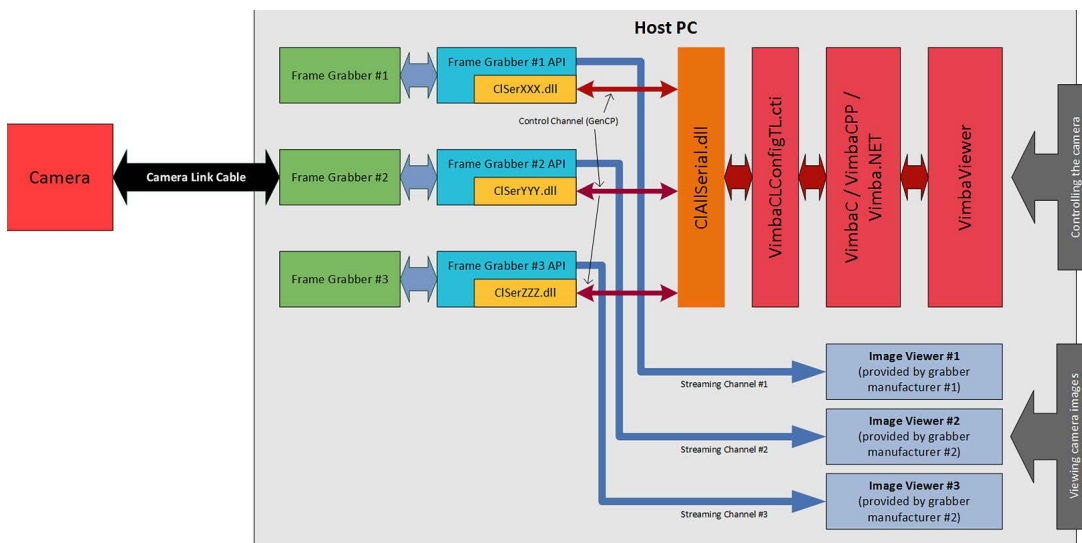

Figure 64: Vimba Config TL block diagram

## Adjusting the transfer speed for your frame grabber

Not all frame grabbers support the same maximum data transfer speed. The maximum bit rate supported by various frame grabbers is vastly different. Therefore, the default bit rate for use of **Vimba** with Camera Link is set to the **minimum bit rate of 9600 bits per second**.

If your frame grabber supports a higher bit rate, it is advantageous to increase the bit rate in **Vimba** to the highest bit rate that the frame grabber supports.



### Take note when changing the transfer speed

- Always change the bit rate using **Vimba**. If the bit rate is changed in the camera, the camera can stop working and require a restart.
- The steps outlined are applicable for **Vimba**, not for any frame grabber SDK.

To increase the bit rate, follow these steps:

Step 1: Open the file VimbaCLConfigTL.xml in the `\Program Files\Allied Vision\Vimba_[version]` directory.

- C:\Program Files\Allied Vision\Vimba\_[version]\VimbaCLConfigTL\bin\Win32
  - C:\Program Files\Allied Vision\Vimba\_[version]\VimbaCLConfigTL\bin\Win64
- These XML files include the modifiable settings, by default the bit rate is denoted as follows:

```
<DefaultBaudRate>9600</DefaultBaudRate>
```

Set this number to the highest bit rate supported by your frame grabber, the highest possible value is **912600** bits per second. Save the file and close.

Step 2: Restart **Vimba** and restart the Goldeye CL camera.

Result: All operations requiring data exchange, especially a firmware update, increase significantly in speed.

## Launching Vimba Viewer

1. Power up the camera and wait until the Camera Link Status LED stops blinking. This indicates booting is completed.
2. Launch **Vimba Viewer**. It may take a few seconds until the camera is shown in the **Detected Cameras** list, depending on the number of cameras connected to the PC and the number of installed frame grabbers.

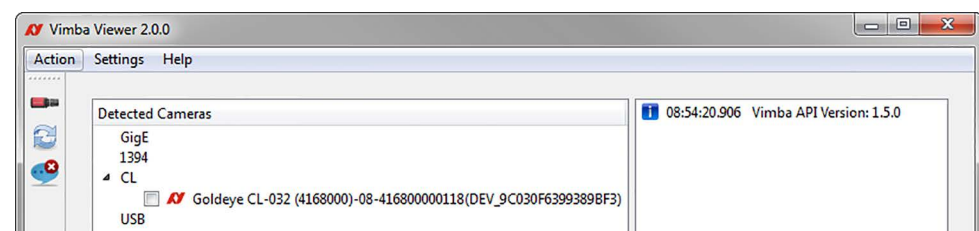

Figure 65: Vimba Viewer - camera detection window

If the camera does not appear after some time, check the following:

- Is the camera connected to the correct grabber port? If the frame grabber has two Camera Link connectors it should be connected to port 1.
  - Has the camera been powered up and booted completely before the **Vimba Viewer** was started? The boot process is indicated by a 1 Hz green-red flashing of the Camera Link status LED. After booting has been finished the LED stays green. It starts flickering in one of the following cases.
    - serial communication is taking place
    - images are transferred to the host
3. Select the desired camera from **Detected Cameras** list.
  4. A new camera window appears, as shown in [Figure 66 on page 254](#). This camera window consists of the following components:
    - Viewer toolbar: controls to customize the live camera view
    - Controller window: shows camera controls
    - Information window: displays camera and event information
    - Camera stats: Statistical information
  5. Launch the viewing application provided by frame grabber manufacturer.

### No Plug and Play mechanism



Camera Link has no Plug and Play mechanism. New cameras are not detected in **Vimba Viewer** if connected to the frame grabber during start (= after loading the transport layer) of **Vimba Viewer**. The same applies if a camera is removed after it has been opened. The **Refresh** button in the **Vimba Viewer** has no effect then.

Because the transport layer is for controlling the camera only, the **Vimba Viewer** window does not show a live image and the histogram window does not show any data. Image display and analysis is done via applications provided by the frame grabber manufacturer.

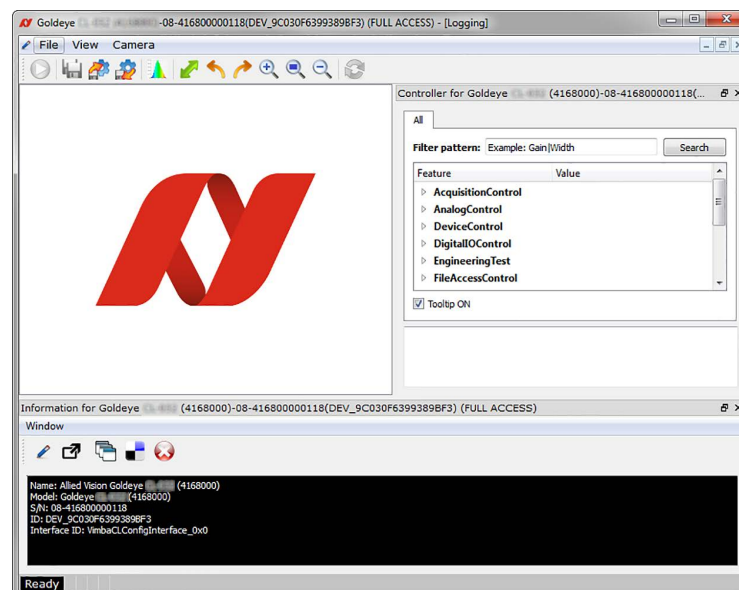

Figure 66: Vimba Viewer window



### Dockable layout

The camera window supports a fully dockable layout that allows user to customize their workspace.



### If components are missing in camera window

If any of the components of the camera window are missing, then do the following:

- Right-click on menu or toolbar
- Select the missing component

## Adjusting camera controls: Controller window

The controller window is displayed in the top right section of the **Vimba Viewer** window, refer to [Figure 66 on page 254](#). It is used to configure the camera frame rate, exposure time, pixel format, and much more. A detailed explanation of camera controls is available in the Goldeye G/CL Features Reference.

## Grabbing images

To grab images, use the viewer application provided by the frame grabber manufacturer. It is necessary to configure the viewer application regarding the incoming image format of the camera. We suggest for best practice:

1. Set **Width**, **Height**, and **PixelFormat** of the camera in the **Vimba Viewer** controller window.
2. Configure the equivalent parameters of the incoming image format for the frame grabber with the frame grabber viewing application identically.
3. Start and stop acquisition with **AcquisitionStart** and **AcquisitionStop**.

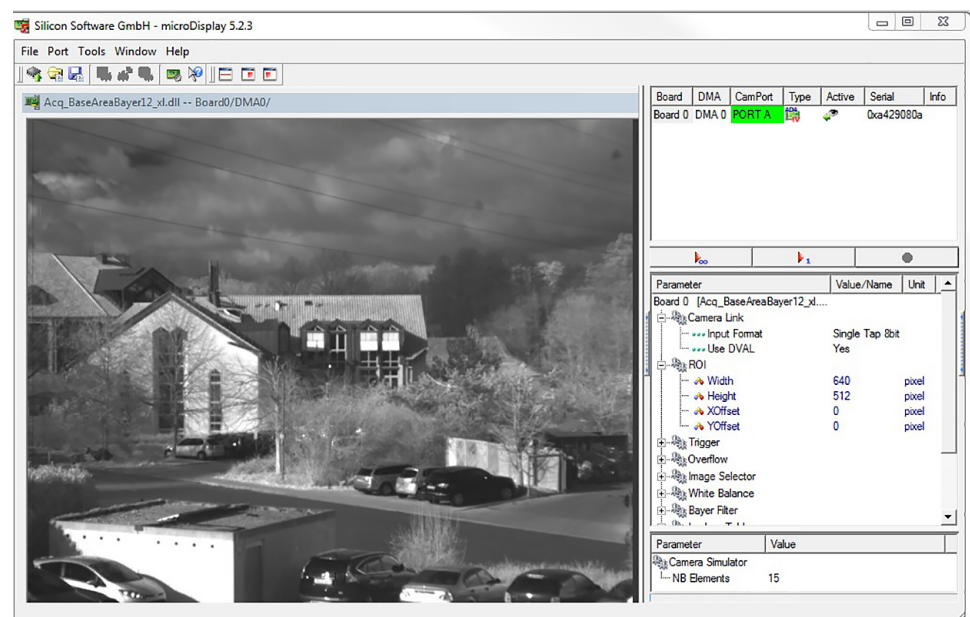

Figure 67: Example frame grabber viewer application



### Grabber configuration files

You can adjust the image parameters within the application or via an external grabber configuration file, depending of the used frame grabber.

Refer to the frame grabber documentation for more information on parameter adjustment.

To obtain frame grabber configuration files, contact visit [www.alliedvision.com/en/about-us/contact-us/technical-support-repair/-/rma](http://www.alliedvision.com/en/about-us/contact-us/technical-support-repair/-/rma).

### Camera information: Information window

The information window is displayed in the bottom section of the **Vimba Viewer** window, see [Figure 70 on page 257](#). It consists of the functionalities as described.



To open the Logging window, click the logging icon, shown left. The logging window provides camera identifying information including the serial and ID number.

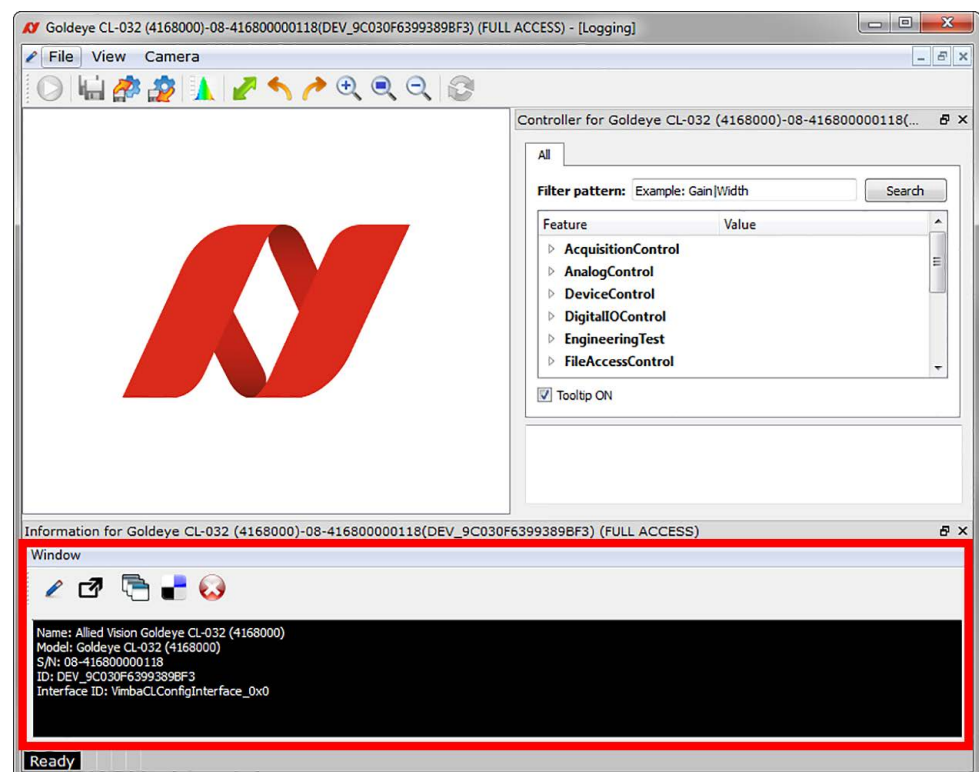

Figure 68: Vimba Viewer with logging window



## Using a custom application

It is possible to access the Goldeye CL camera without using the **Vimba** configuration transport layer. In this case, the custom application must open the COM port of the grabber via the `cllserial.dll` (or `clserXXX.dll`) to establish a communication channel between the host and the camera. The protocol used for communication with the camera is GenICam GenCP.

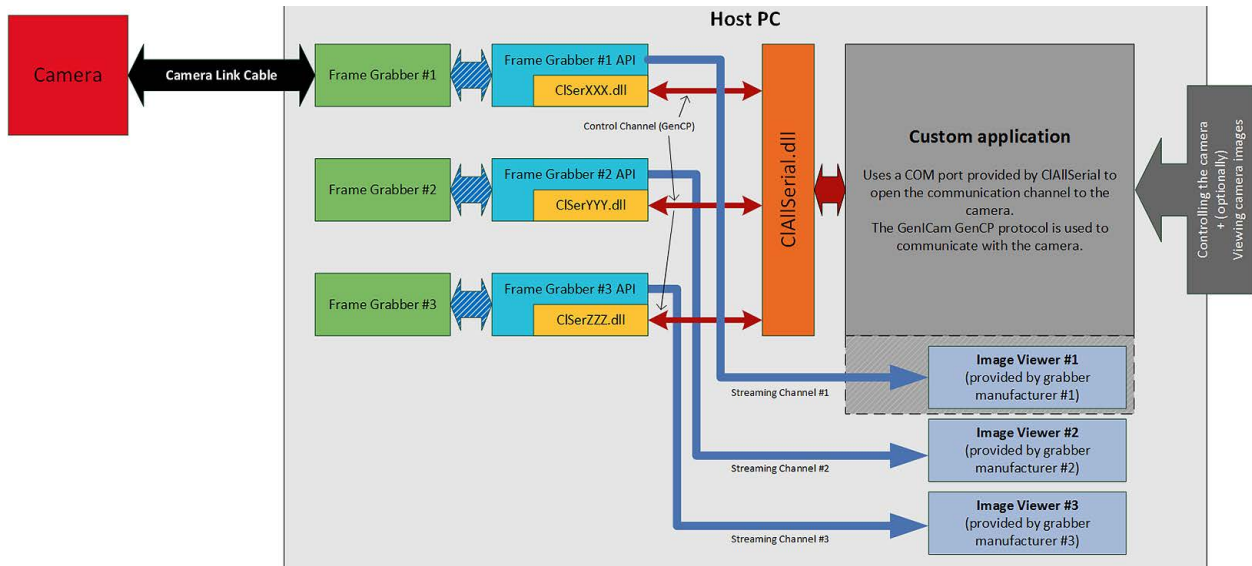

Figure 69: Custom GenCP application block diagram



### Applicable standards

- The Camera Link Specification V2.0. You can download it from the AIA website: [www.visiononline.org/vision-standards-details.cfm?type=6](http://www.visiononline.org/vision-standards-details.cfm?type=6)
- The GenICam GenCP V1.1. You can download it from the EMVA website: [www.emva.org/standards-technology/genicam/genicam-downloads/](http://www.emva.org/standards-technology/genicam/genicam-downloads/)

## Using frame grabber transport layer

If you are using the transport layer provided by the manufacturer of the frame grabber, adjusting camera features and grabbing images is handled via an application from the frame grabber manufacturer.

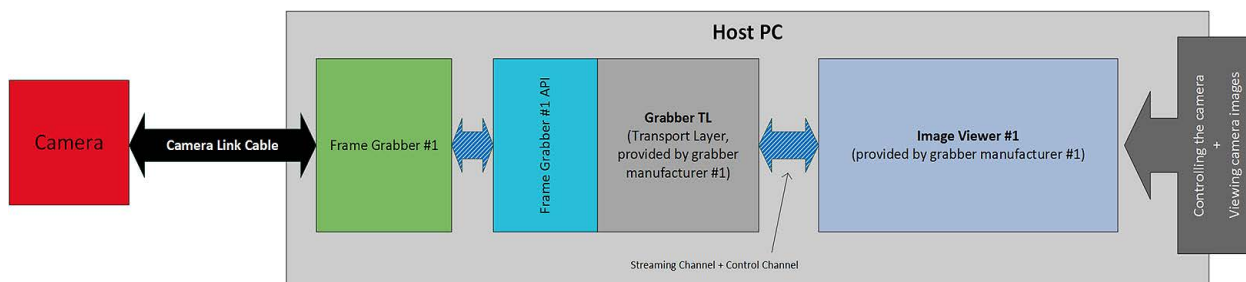

Figure 70: Frame grabber transport layer block diagram

# Troubleshooting

## Is the camera getting power?

Check the Camera Link status LED underneath the Camera Link port on the backside of the camera. If the camera is connected to power, the LED displays a steady green color.

## Is the camera powered, but not detected in viewer?

- **Is the camera connected to the correct grabber port?**

If the frame grabber has two Camera Link connectors, it should be connected to port 1.

If the frame grabber has two Camera Link connectors, it does not necessarily mean that it is a DUAL-BASE grabber. Refer to the frame grabber manual for more information.

- **Has the camera been powered up and booted completely before the Vimba Viewer was started?**

During the boot process, the Camera Link status LED under the Camera Link port flashes with 1 Hertz in green-red. After booting has been finished, the LED stays green.

Note that no Plug and Play mechanism is available with Camera Link. If a camera is attached to the frame grabber after the transport layer is loaded (during start of **Vimba Viewer**), the new camera will not be detected. If a camera is removed after it has been opened it can also not be detected.

## Is the camera listed in viewer, but images cannot be acquired?

- Compare the incoming image format of the frame grabber with the parameters set in the camera. Verify that width, height, and pixel format expected by the frame grabber are equal at the camera side.
- Check if the frame grabber tap configuration is the same as the camera tap configuration (`DeviceTapGeometry`).

# Using lens mounts and filters

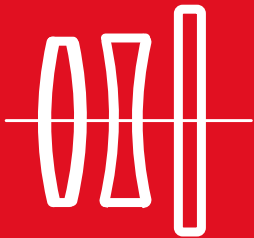

This chapter includes:

Available lens mount adapters .....	260
Changing lens mount adapters .....	260
Using C-Mount adapter Type 2 .....	265

## Available lens mount adapters

See [Lens mount adapters by model](#) on page 208 for C-Mount adapters Type 1 and Type 2, F-Mount adapters, and M42-Mount adapters.

## Changing lens mount adapters

The lens adapter is screwed onto the M42 thread of the camera body. To exchange it with a different adapter, unscrew it and screw on the other adapter.

For consistent image quality, we recommend using only Allied Vision lens adapters.



### Take special care when removing filter

- Removing the filter from the camera requires special care.
- Ask your distribution partner for assistance if you are not confident with the procedure.
- To avoid contamination, never touch optical surfaces with bare hands.



### NOTICE

#### Damage to the camera

Mount adapters for Goldeye cameras are secured with locking screws, see [Figure 71](#). These locking screws must be loosened before removing mount adapters.

- Loosen the locking screws before removing mount adapters.
- Only use your hands to screw mount adapters on or off.
- Fasten the locking screws after attaching mount adapters.

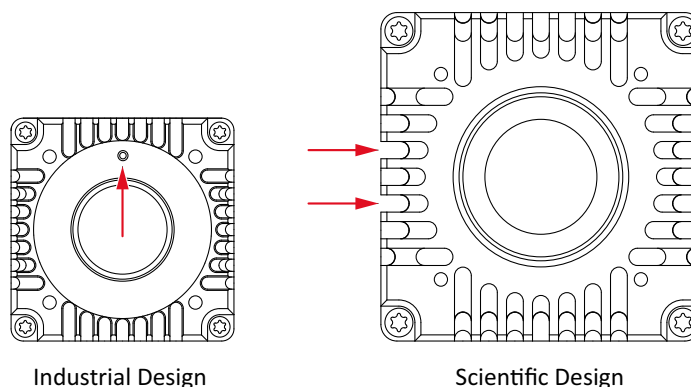

Figure 71: Position of safety screws on mount adapters for Goldeye G/CL

## Changing filters in C-Mount adapters Type 1



### C-Mount adapters

- Difference between C-Mount adapters Type 1 and Type 2: See [Lens mount adapters by model](#) on page 208 for
- C-Mount adapter Type 2: See [Using C-Mount adapter Type 2](#) on page 265

If the C-Mount adapter has an optical filter fitted, it is possible to change the filter. (See [Bandpass filter 1450 nm \(water filter\)](#) on page 229 for more details on mount adapters with pre-fitted filters.)

To change the filter of the C-Mount lens adapter, follow the instructions outlined in [Figure 72](#).

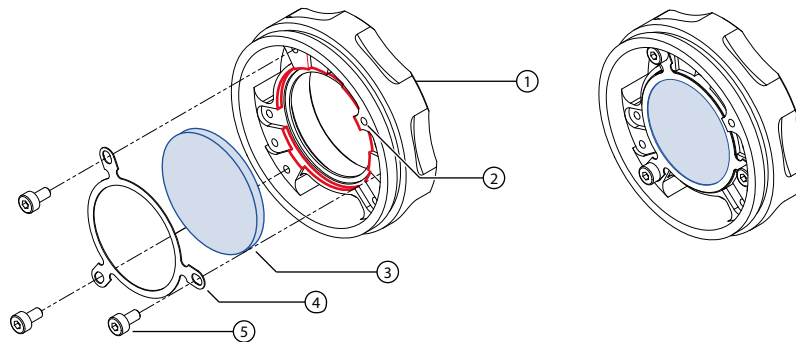

Figure 72: Changing the filter in the C-Mount adapter

Do not remove the adapter if a lens is mounted to the adapter. Ensure there is no lens mounted to the adapter.

## Removing the adapter from the camera

Unscrew the adapter (1) from the camera:

- Loosen the locking screw (2, shown from back of adapter) on the outside of the mount adapter. See [Figure 71](#) on page 260 for the position of the locking screws.
- Use a 1.3 mm hex key for **Goldeye G/CL-008 Cool TEC1, G/CL-032 Cool TEC2** models.
- Use a 0.9 mm hex key for **all other models**.
- To avoid penetration of foreign substances into the camera, ensure that the front flange is covered with a dust cap. See [Avoiding the necessity of camera cleaning](#) on page 330.

## Removing the filter from the mount adapter

On the back side of the mount, loosen the three cylinder bolts (5) of the filter fixing ring (4), using a Torx T6 tool.

1. Remove the fixing ring.
2. Remove the existing filter (3) from the adapter.

## Installing a filter into the mount adapter

1. Insert the new filter into the matching recess:
  - See [Figure 72 on page 261](#) (blue = filter, red = filter recess).
  - See [Table 191: Specifications of mount adapters](#) on page 209 for dimensions of suitable filters.
2. Reinsert the fixing ring into the adapter.
3. Fix the ring with the three cylinder bolts. Note there are three sets of threads to suit filters of different thicknesses:
  - Tighten the bolts with a maximum torque of 0.25 Nm.

## Attaching the mount to Industrial Design models

1. Screw the adapter into the camera.
2. Tighten the locking screw with a maximum torque of 0.1 Nm.

## Attaching the mount to Scientific Design models

When used with Goldeye Scientific Design models, the mount adapter is secured by two locking screws on the side of the camera. The thread in the mount adapter needs to be closed with a thread plug to avoid light incidence.

To apply the thread plug to a C-Mount adapter, follow the steps outlined in [Figure 73](#).

1. Push the thread plug through the locking thread, from front to back, until the end lines up with the adapters front plane.
2. Cut off the excess length on the backside of the mount adapter with a sharp knife or scissors.

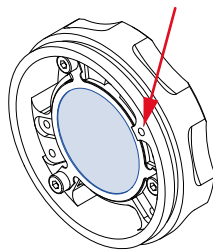

*Figure 73: Position to cut off the thread plug on the backside of the mount adapter.*

## Changing the filter in F-Mount adapters

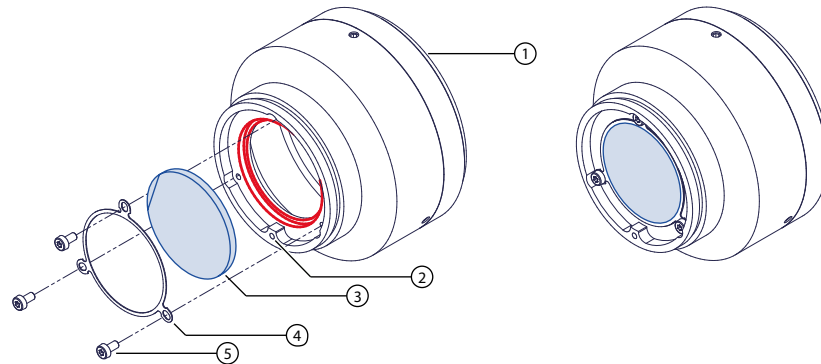

Figure 74: Changing the filter in the F-Mount adapter

If the F-Mount adapter has an optical filter fitted, it is possible to change the optical filter. (See [Bandpass filter 1450 nm \(water filter\)](#) on page 229 for more details on mount adapters with pre-fitted filters.)

To change the filter of the F-Mount lens adapter, follow the instructions outlined.

Removing the adapter from the camera

1. Remove the lens that might be screwed into the F-Mount adapter.
2. Unscrew the adapter (1) from the camera:
  - Loosen the locking screw (2) on the outside of the mount adapter. See [Figure 71 on page 260](#) for the position of the locking screws. Use a 1.3 mm hex key for **Goldeye G/CL-008 Cool TEC1, G/CL-032 Cool TEC2** models. Use a 0.9 mm hex key **for all other models**.
  - To avoid penetration of foreign substances into the camera, ensure that the front flange is covered with a dust cap. See [Avoiding the necessity of camera cleaning on page 330](#).

## Removing the filter from the mount adapter

1. On the back side of the mount, loosen the three cylinder bolts (5) of the filter fixing ring (4), using a Torx T6 tool.
2. Remove the fixing ring.
3. Remove the existing optical filter (3) from the adapter.

## Installing a optical filter into the mount adapter

1. Insert the new optical filter into the matching recess:
  - See [Table 74 on page 263](#) (blue = filter, red = filter recess).
  - See [Table 191: Specifications of mount adapters](#) on page 209 for dimensions of suitable optical filters.
2. Insert the fixing ring into the adapter.
3. Fix the ring with the three cylinder bolts:
  - Tighten the bolts with a maximum torque of 0.25 Nm.

## Attaching the mount to the camera

1. Screw the adapter into the camera again.
2. Tighten the locking screw with a maximum torque of 0.1 Nm.

## Changing the filter in M42-Mount adapters

To avoid scratching or other damage to optical filters, always store away unused optical filters carefully.



### NOTICE

#### Damage to the sensor

If M42-Mount lenses are screwed directly into the camera when no lens mount adapter is attached, the sensor and the sensor board can be damaged.

Always use the M42-Mount adapter when working with M42-lenses.

If the M42-Mount adapter has an optical filter fitted, it is possible to change it. (See [Bandpass filter 1450 nm \(water filter\)](#) on page 229 for more details on mount adapters with pre-fitted filters.)

To change the filter of the M42-Mount lens adapter, follow the instructions outlined.

## Removing the adapter from the camera

1. Remove the lens that might be screwed into the M42-Mount adapter.
2. Unscrew the adapter (1) from the camera:
  - Loosen the locking screw (2, shown from back of adapter) on the outside of the mount adapter. See [Figure 71 on page 260](#) for the position of the locking screws.  
Use a 1.3 mm hex key for **Goldeye G/CL-008 Cool TEC1, G/CL-032 Cool TEC2** models.  
Use a 0.9 mm hex key **for all other models**.
  - To avoid penetration of foreign substances into the camera, ensure that the front flange is covered with a dust cap. See [Avoiding the necessity of camera cleaning on page 330](#).

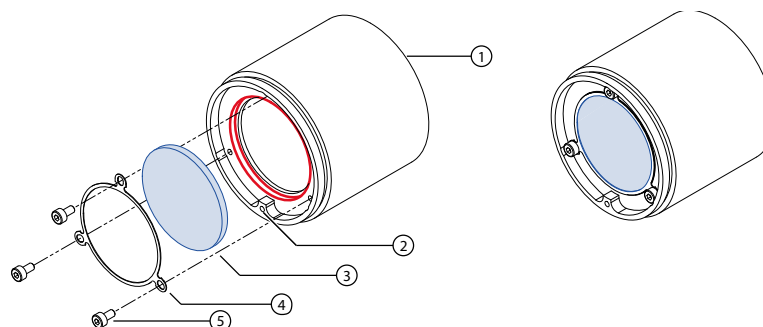

Figure 75: Changing the filter in the M42-Mount adapter



## Removing the filter from the mount adapter

1. On the back side of the mount, loosen the three cylinder bolts (5) of the filter fixing ring (4), using a Torx T6 tool.
2. Remove the fixing ring.
3. Remove the existing optical filter (3) from the adapter.

## Installing a filter into the mount adapter

1. Insert the new optical filter into the matching recess.
  - See [Figure 75](#) (blue = filter, red = filter recess).
  - See [Table 191: Specifications of mount adapters](#) on page 209 for dimensions of suitable optical filters.
2. Insert the fixing ring into the adapter.
3. Fix the ring with the three cylinder bolts.
  - Tighten the bolts with a maximum torque of 0.25 Nm.

## Attaching the mount to the camera

1. Screw the adapter into the camera.
2. Tighten the locking screw with a maximum torque of 0.1 Nm.

# Using C-Mount adapter Type 2



### C-Mount adapters

- Difference between C-Mount adapters Type 1 and Type 2: See [Lens mount adapters by model](#) on page 208 for
- C-Mount adapter Type 1: See [Changing filters in C-Mount adapters Type 1](#) on page 261

### Only for the following models:

Goldeye G/CL-008 XSWIR 1.9/2.2 TEC2, G/CL-030 TEC1, G/CL-034 TEC2, G/CL-034 XSWIR 1.9/2.2 TEC2, G/CL-130 TEC1

## Adjusting the C-Mount

Flange focal distance is the optical distance from the mounting flange to image sensor die. Goldeye cameras with C-Mount are calibrated for a flange focal distance of standard 17.526 mm.

Sometimes the C-Mount must be adjusted; for example, to compensate for C-Mount lenses that deviate from the specified flange focal distance. In this case, follow the instructions in this section.

## Preconditions

- Goldeye camera (model range see above) with C-Mount adapter Type 2
- C-Mount lens with a long focal length, or an adjustable zoom lens that can be focused to infinity
- Target at minimum 10 to 15 meters distance with clear structures for easy focusing
- Locking wrench, Allied Vision product code 02-5003A



Contact the Allied Vision Sales team to purchase the hexagonal lens adjustment wrench for C-Mount locking rings of Goldeye cameras (product code 02-5003A).

## Part description

Figure 76 shows the C-Mount ring and the tool to loosen and tighten the locking ring. The functionality is the same with Industrial Design and Scientific Design.

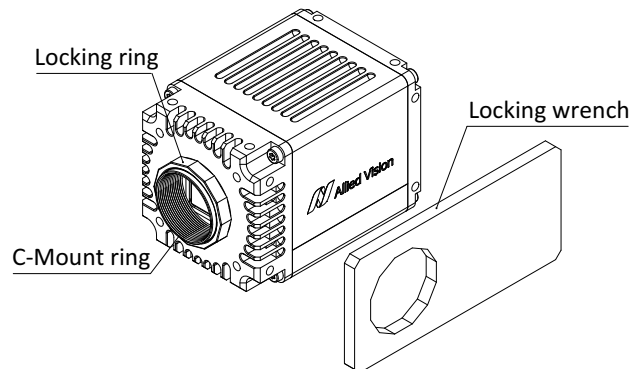

Figure 76: Goldeye camera with C-Mount adapter Type 2 and locking wrench

## Instructions

1. Make sure the C-Mount lens is threaded firmly onto the C-Mount ring.
2. Loosen the locking ring. Be careful not to scratch the camera.
3. When the locking ring is loose, unthread the ring a few turns from the camera face.
4. Point the lens towards the target.
5. Set the lens to infinity.
6. Rotate the lens and C-Mount ring in both directions until the image is focused.
7. Tighten the locking ring.
8. Recheck the focus.
9. If focus has been lost, continue with [Step 2](#).
10. If the image is still in focus, you are done.

## Replacing filters

### Only for the following models:

Goldeye G/CL-008 XSWIR 1.9/2.2 TEC2, G/CL-030 TEC1, G/CL-034 TEC2, G/CL-034 XSWIR 1.9/2.2 TEC2, G/CL-130 TEC1



### Available filters for models with C-Mount adapter Type 2

See [Filters with C-Mount adapter Type 2](#) on page 230. Filters by Allied Vision include a locking wrench to replace filters

## Preconditions

- Goldeye camera (model range see above) with C-Mount adapter Type 2
- Suitable filter and wrench.

## Part description

[Figure 77](#) shows the wrench to replace filters. The functionality is the same with Industrial Design and Scientific Design.

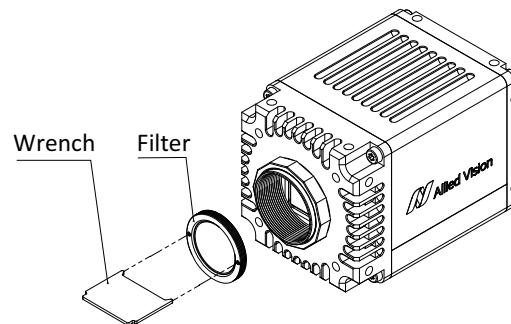

Figure 77: Goldeye camera with C-Mount adapter, filter, and locking wrench

## Inserting filters



### Keep dust away

We recommend you to hold the camera with the lens mount facing the ground to keep dirt out.

1. Remove the lens or protection cap from the C-Mount.
2. Place the filter on the wrench, with the pins of the wrench fitting into the holes of the filter ring.
3. Holding the filter with the wrench, engage the filter to the C-Mount.
4. Screw the filter clockwise into the C-Mount until you feel resistance.
5. Place a lens or protection cap on the C-Mount to keep dust away.

## Removing filters

1. Remove the lens or protection cap from the C-Mount.
2. Insert the pins of the wrench into the holes of the filter ring.
3. Screw the filter counter clockwise out of the C-Mount.
4. Place a lens or protection cap on the C-Mount to keep dust away.
5. Store the filter protected from dust.

# Camera interfaces



This chapter includes:

GigE port, back panel, and status LEDs (GigE).....	272
CL port, back panel, and status LED (CL) .....	272
Power supply (GigE and CL models) .....	274
I/O description (GigE and CL models).....	276
Frame grabber requirements (CL) .....	287
Timing (CL) .....	288
Starting the acquisition automatically (CL).....	291

# GigE port, back panel, and status LEDs (GigE)

## Gigabit Ethernet port

The Gigabit Ethernet (GigE) port conforms to the IEEE 1000BASE-T standard for Gigabit Ethernet. We recommend using CAT-5e compatible cabling and connectors or better for best performance.

Goldeye G cameras have a GigE interface and work with standard GigE hardware and cables, with cable lengths up to 100 meters.

## Back panel

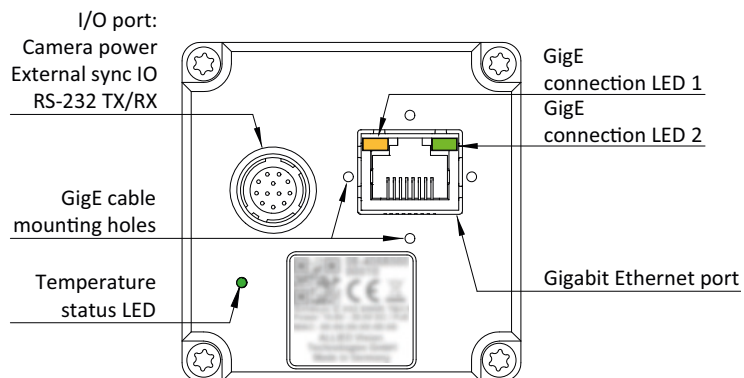

Figure 78: Connection ports and LEDs of Goldeye G Industrial Design models

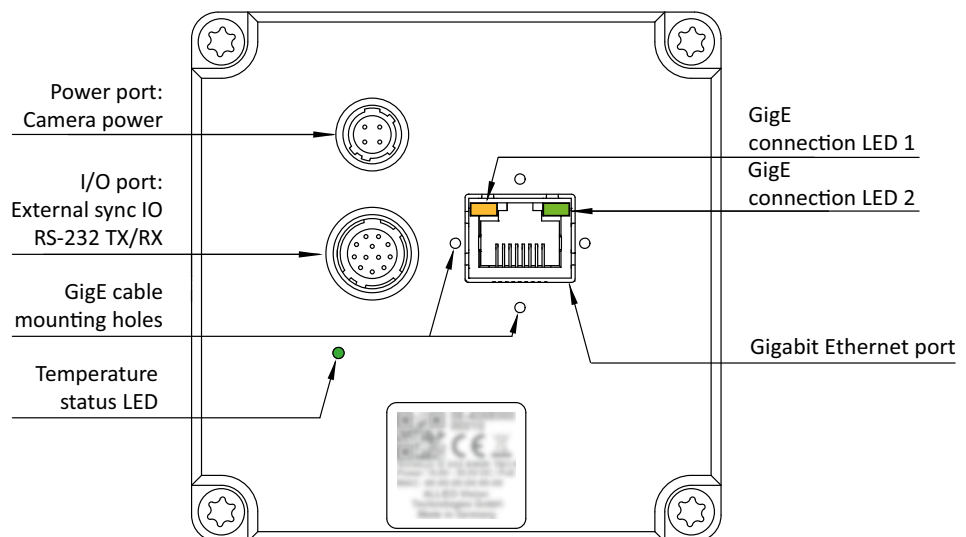

Figure 79: Connection ports and LEDs of Goldeye G Scientific Design models

The Goldeye G has the following LEDs on its rear panel:

- Two LEDs at the RJ45/8P8C port showing the GigE connection status.
- One temperature status LED showing the sensor and camera temperature status.

For detailed explanations on temperature status and temperature management of the Goldeye G/CL, refer to [Temperature control on page 312](#).

## GigE status LEDs



LED	LED color	Status
LED 1	 Continuous or flashing)	Ethernet activity
LED 2	 Flashing	Camera is connected to power
LED 2	 Continuous	Once the camera is booted, LED 2 remains green as long as the camera is connected to power, even if connection with the host is lost.

Table 223: Goldeye G: GigE status LEDs

# CL port, back panel, and status LED (CL)

## Camera Link port

Goldeye CL cameras are equipped with a Camera Link (CL) interface that conforms to the Camera Link V2.0 standard.

## Back panel

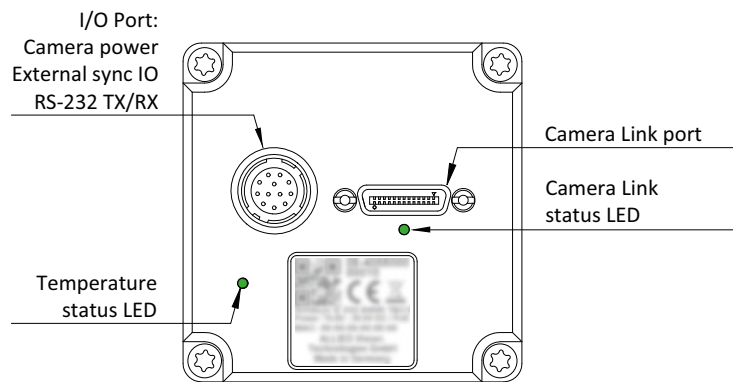

Figure 80: Connection ports and LEDs of Goldeye CL Industrial Design models

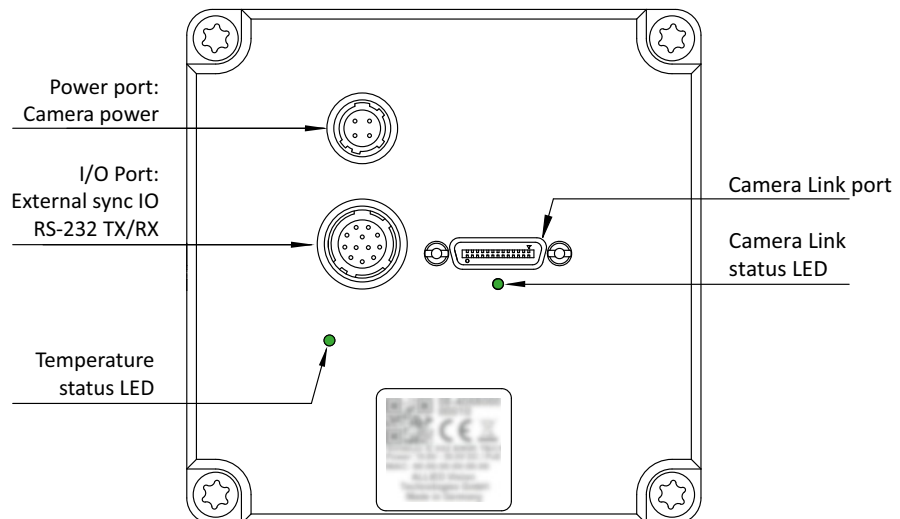

Figure 81: Connection ports and LEDs of a Goldeye CL Scientific Design models



The Goldeye CL has the following LEDs on its rear panel:

- One Camera Link status LED showing the Camera Link connection status.
- One temperature status LED showing the sensor and camera temperature status. See [TEC1](#), [TEC2](#), [TECless](#) on [page 313](#) for further explanation.

## Camera Link status LED



LED codes	Status and description
	<b>Booting</b>
1 Hz periodic flashing	<ul style="list-style-type: none"> <li>• Boot phase after powering up the camera</li> <li>• Firmware update in progress</li> </ul>
	<b>Idle</b>
Continuous	Camera is idle and ready.
	<b>Transmission</b>
Non-periodic fast flashing	During image transmission, the LED toggles between red and green. Traffic on the serial control channel is shown by additional irregular fast green-red flashing. This may cause the LED to appear amber colored.

Table 224: Camera Link status LED



### Read more about temperature management

For detailed explanations on temperature status and temperature management of the Goldeye G/CL, refer to [Temperature control on page 312](#).

## Power supply (GigE and CL models)

Depending on the model, various options are available to provide Goldeye cameras with power. [Table 225](#) lists the options available for all Goldeye models. All Goldeye models do not work in reverse polarity. Refer also to [Table 228](#) on page 277 and [Table 230](#) on page 278 for details of pin assignment for each connector.



### Ensure correct power connection

The DC port is not intended to be connected to a DC distribution network.

	Hirose	PoE
<b>Goldeye G models</b>		
G-008 TEC1 G-030 TEC1 G-032 TEC1 G-033 TEC1 and TECless G-034 TEC1 G-130 TEC1	Through 12-pin Hirose I/O port <ul style="list-style-type: none"> <li>Pin 1, External GND</li> <li>Pin 2, External Power</li> </ul>	Through the GigE port by <b>PoE (IEEE 802.3at Type 1 Class 0)</b> supported NIC, switch, or injector
G-008 Cool TEC1	Through 4-pin Hirose power port <ul style="list-style-type: none"> <li>All 4 pins are used.</li> <li>Pin 2 of the 12-pin Hirose I/O port is not used.</li> </ul>	Through the GigE port by <b>PoE (IEEE 802.3at Type 1 Class 0)</b> supported NIC, switch, or injector
G-008 XSWIR 1.9 TEC2 G-008 XSWIR 2.2 TEC2 G-032 Cool TEC2 G-034 TEC2 G-034 XSWIR 1.9 TEC2 G-034 XSWIR 2.2 TEC2	Through 4-pin Hirose power port <ul style="list-style-type: none"> <li>All 4 pins are used.</li> <li>Pin 2 of the 12-pin Hirose I/O port is not used.</li> </ul>	Through the GigE port by a <b>PoE+ (IEEE 802.3at Type 2 Class 4)</b> supported NIC, switch, or injector
<b>Goldeye CL models</b>		
CL-008 TEC1 CL-030 TEC1 CL-032 TEC1 CL-033 TEC1 and TECless CL-034 TEC1 CL-130 TEC1	Through 12-pin Hirose I/O port <ul style="list-style-type: none"> <li>Pin 1, External GND</li> <li>Pin 2, External Power</li> </ul>	Not applicable
CL-008 Cool TEC1 CL-008 XSWIR 1.9 TEC2 CL-008 XSWIR 2.2 TEC2 CL-032 Cool TEC2 CL-034 TEC2 CL-034 XSWIR 1.9 TEC2 CL-034 XSWIR 2.2 TEC2	Through 4-pin Hirose power port <ul style="list-style-type: none"> <li>All 4 pins are used.</li> <li>Pin 2 of the 12-pin Hirose I/O port is not used.</li> </ul>	Not applicable

Table 225: Differences in power supply between various Goldeye models

## Power supply via Hirose connector

### Goldeye Industrial Design models (by I/O port)

Use one of the following connections.

- Power supply with Hirose 12-pin connector
- I/O cable with Hirose 12-pin connector in conjunction with a standard power supply adapter

### Goldeye Scientific Design models (by power port)

Use one of the following connections:

- Power supply with Hirose 4-pin connector
- Power cable with Hirose 4-pin connector in conjunction with a standard power supply adapter.

You cannot use the Hirose 12-pin I/O connector to supply Goldeye Scientific Design models with power.



#### **Ensure a correct power supply**

In case the camera is provided with power via the I/O connector, always ensure that the voltage at the camera input lies in the designated requirement of 10.8 V to 30.0 V.

## Power supply via Gigabit Ethernet (Goldeye G only)

You can supply Goldeye G models with power through the Gigabit Ethernet port by using any standard Power over Ethernet (PoE or PoE+) supported network connection.

The pin assignment of the RJ45/8P8C connector is according to the Ethernet Standard (IEEE 802.3 1000BASE-T), which supports cable lengths of up to 100 meters. All Goldeye G models can obtain power from IEEE 802.3at compliant Power Sourcing Equipment (PSE) devices, such as switches, injectors, or NICs.

If any Hirose connector provides a valid DC voltage to the camera, and the GigE connector is connected via PoE at the same time, the camera obtains power from the Hirose connector only.



#### **Goldeye G models: Minimizing Power consumption**

If the camera operates under higher temperature conditions, you should consider powering the camera via the I/O connector instead of PoE, because PoE contributes to the heat build-up inside the camera.

Refer to [Specifications \(GigE models\) on page 51](#) for details on power consumption.

# I/O description (GigE and CL models)

## I/O connectors and pin assignment



### NOTICE

#### Damage to the camera by surge

ESD by improper grounding can damage the camera.  
Ensure proper grounding.



#### Avoid electromagnetic interferences

For all power and interface connections, use only shielded cables.

I/Os for Goldeye G/CL cameras use the 12-pin Hirose connector.

## I/O types

### Non-isolated I/Os

- One non-isolated line-in (3.3 V LVTTTL, 5 V TTL tolerated, see [Table 228](#) on page 277)
- One non-isolated line-out (5 V TTL)
- (Camera Link only) Four non-isolated LVDS inputs (CC ports)

### Opto-isolated I/Os

- One opto-isolated line-in
- Two opto-isolated line-out
- Maximum isolated power voltage is 30 V
- Line-in voltages:
  - $V_{in}(\text{low}) = 0.0 \text{ V to } 1.0 \text{ V}$
  - $V_{in}(\text{high}) = 3.0 \text{ V to } 24.0 \text{ V}$

### Trigger cables with 12-pin Hirose connector (overview)

Cable side Hirose connectors (without cable) and I/O cables with Hirose connector are available for purchase from Allied Vision.

Product code	Description
1068908	Trigger cable In1 BNC LVTTTL with Hirose 12-pin connector, 2 m
1068909	Trigger cable In1 BNC LVTTTL with Hirose 12-pin connector, 5 m

Table 226: Available trigger cables with Hirose 12-pin connector

The maximum length of I/O cables must not exceed 30 meters.

## Pin assignment

### Hirose 12-pin connector

	Quick links
	External GND and external power (pin 1 and pin 2) for industrial design models
	RxD RS232 and TxD RS232 (pin 8, pin 9)
	Isolated out power (pin 10)
	In 1- non-isolated (pin 4)
	In 2- opto-isolated (pin 11)
	Non-isolated output Out 1
	Opto-isolated outputs Out 2 and Out 3

Table 227: Overview of I/O connections of the 12 pin Hirose connector

Pin	Color code	Signal	I/O	Level	Description
1	Blue	External GND	In/ Out	GND for RS232 and external power	Ext. ground for RS232, TTL I/Os (and ext. power)
2	Red	External Power <sup>1</sup>	In	10.8 V to 30.0 VDC	Power supply <sup>1</sup>
3	Violet	Video Type Auto Iris Out	Out	Not applicable	Video iris
4	Gray	In 1	In	V <sub>in</sub> (low) 0.0 V to 0.8 V V <sub>in</sub> (high) 2.0 V to 5.0 V	Input 1 non-isolated (LineIn1)
5	Yellow	Out 3	Out	Open emitter, max. 20 mA	Output 3 opto-isolated (LineOut3)
6	Green	Out 1	Out	TTL (5 V, max. 20 mA)	Output 1 non-isolated (LineOut1)
7	Brown	Isolated In GND	In	Common GND for opto-isolated inputs	Camera common input ground (In GND)
8	White	RxD RS232	In	RS232	Terminal receive data
9	Black	TxD RS232	Out	RS232	Terminal transmit data
10	Orange	Isolated Out Power	In	Common supply voltage for outputs max. 30 VDC	External power input for digital outputs (Out V <sub>CC</sub> )
11	White/Black	In 2	In	V <sub>in</sub> (low) 0.0 V to 1.0 V V <sub>in</sub> (high) 3.0 V to 24.0 V	Input 2 opto-isolated (LineIn2)
12	White/Brown	Out 2	Out	Open emitter, max. 20 mA	Output 2 opto-isolated (LineOut2)

<sup>1</sup> Scientific Design models: External power is supplied by 4-pin Hirose connector only, pin 2 of the 12-pin connector is not connected.

Table 228: Pin assignment for the 12 pin Hirose connector

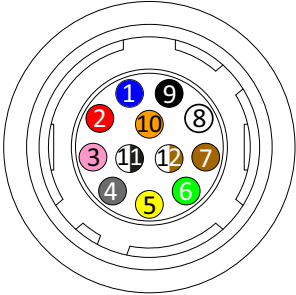
### Hirose 4-pin connector

	Quick links
	<p>External GND and external power(pin 1 to pin 4) for Scientific Design models</p>

Table 229: Overview of connections of the 4 pin Hirose connector

Pin	Color code	Signal	I/O	Level	Description
1	Black	External Power	In	10.8 V to 30.0 VDC	External power
2	Brown	External Power	In	10.8 V to 30.0 VDC	External power
3	Red	External GND	In	GND external power	External ground for external power
4	Orange	External GND	In	GND external power	External ground for external power

Table 230: Pin assignment for the 4 pin Hirose connector

## I/O definitions

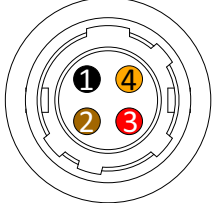
### External GND and external power

#### Goldeye Industrial Design models

Use pins 1 and 2 of the Hirose 12-pin connector to power the camera:

- G/CL-008 TEC1
- G/CL-030 TEC1
- G/CL-032 TEC1
- G/CL-033 TEC1, G/CL-033 TECless
- G/CL-034 TEC1
- G/CL-130 TEC1

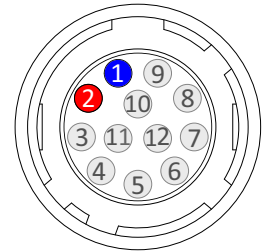

#### Goldeye Scientific Design models

Use pin 1 to pin 4 of the Hirose 4-pin connector to supply the camera with power:

- G/CL-008 Cool TEC1
- G/CL-008 XSWIR 1.9/2.2 TEC2
- G/CL-032 Cool TEC2
- G/CL-034 TEC2
- G/CL-034 XSWIR 1.9/2.2 TEC2

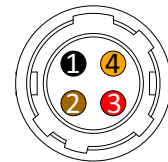

For more information on power supply refer to [GigE status LEDs on page 271](#).



#### NOTICE

#### Damage to the camera by exceeding the maximum input voltage

Apply a maximum input voltage of 30 VDC.

#### RxD RS232 and TxD RS232 (pin 8, pin 9)

These signals are RS232 compatible. These signals are not optically isolated. Connect RS232 ground to Camera GND to complete the RS232 circuit. Communication takes place at a bandwidth of up to 115,200 bits per second (customer adjustable).

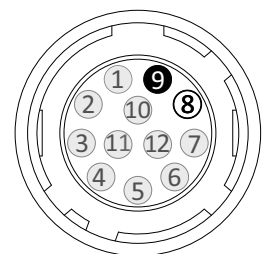



### More information on the RS232 interface

For complete RS232 description and usage on GigE cameras, see the application note RS232 Port:

[www.alliedvision.com/en/support/faqs-application-notes](http://www.alliedvision.com/en/support/faqs-application-notes)

### Isolated out power (pin 10)

Connect the **Isolated Out Power** to a power source for isolated signals **Out 2** and **Out 3**. The voltage requirement is 3 to 30 VDC. The current requirement for this supply is a function of the optical insulator collector current and the number of outputs used in the system. **Isolated Out Power** wiring should be physically close to **Out 2 / Out 3** wiring to prevent parasitic coupling.

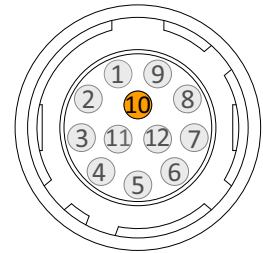

### Input signals

Input signals allow the camera to be synchronized to an external event. The camera can be programmed to trigger on the rising edge, falling edge, both edges, or level of the signal. The camera can also be programmed to capture an image at some programmable delay time after the trigger event.

#### In 1 - non-isolated (pin 4)

**In 1** is not electrically isolated and can be used when environmental noise is inconsequential, and a faster trigger response is required. To complete the trigger circuit, connect trigger ground to External GND.

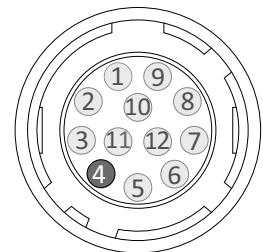

Trigger signal	Input current
Required trigger signal:	LVTTL (3.3 V), TTL (5 V) tolerated
Input current to be expected in TTL mode:	3 mA
Input current to be expected in LVTTL mode:	0.3 mA

Table 231: Input 1 trigger signal and input current



### In 2 - opto-isolated (pin 11)

**In 2** is optically isolated and can be used in electrically noisy environments to prevent false trigger events. To complete the trigger circuit, connect trigger ground to **Isolated In GND**. Compared to the non-isolated trigger, **In 2** has a longer propagation time.

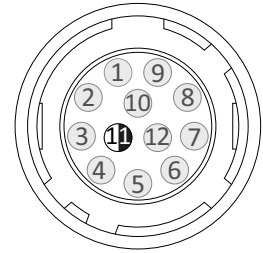

Trigger signal	Input current
Trigger input voltage: $V_{in}$ (low)	0.0 V to 1.0 V
Trigger input voltage: $V_{in}$ (high)	3.0 V to 24.0 V
Input current to be expected	5 mA

Table 232: Input 2 trigger signal and input current

### Isolated input block diagram

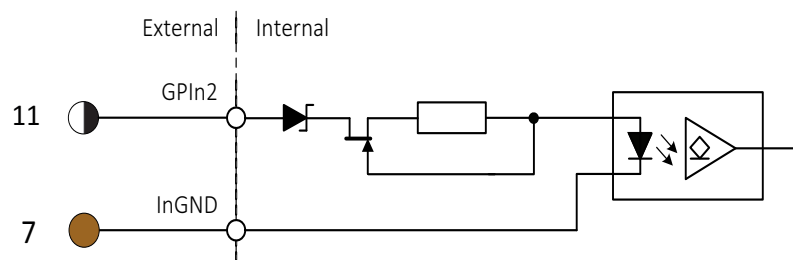

Figure 82: Goldeye G/CL isolated input block diagram

The inputs can be connected directly to the system for voltages up to 24 VDC. An external resistor is not necessary.

### Goldeye G/CL isolated input delay and minimum pulse width

The minimum pulse width for all Goldeye G/CL cameras is:

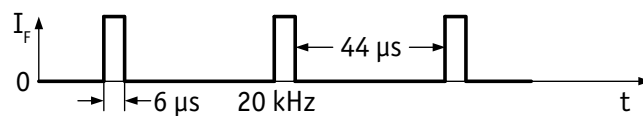

Figure 83: Goldeye G/CL minimum pulse width

### Test conditions

The input signal was driven with 3.3 V (LVTTTL) and no external additional series resistor was used.

## CC1 - CC4 (Camera Link only)

The Camera Link signals CC1- CC4 are LVDS (Low-voltage differential signaling) pairs and are located on the SDR-26 connector. They are exclusively controlled by the frame grabber the camera is connected to. For further information refer to the Camera Link standard.

## Output signals

Output signals can be assigned to a variety of internal camera signals via software. They can be configured to active high or active low. The internal camera signals are listed in [Table 237](#) on page 285.

Output signal	Description
Exposing	Indicates when camera is integrating light.
Trigger Ready	Indicates when the camera is ready to accept a trigger signal.
Trigger Input	A relay of the trigger input signal used to “daisy chain” the trigger signal for multiple cameras.
Readout	Valid when the camera is reading out data.
Imaging	Valid when the camera is exposing or reading out.
Strobe	Programmable pulse based on one of the events as listed.
GPO	User programmable binary output.

Figure 84: Goldeye G/CL internal camera signals

### Non-isolated output Out 1

The **Out 1** (pin 6) signal is not electrically isolated and can be used when environmental electrical noise is inconsequential, and faster trigger response is required. Connect signal ground to **External GND** to complete the external circuit.

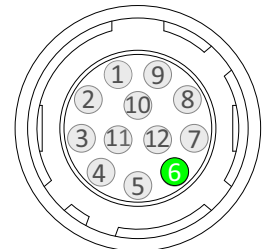

Signal	Output
Output signal	TTL (5 V)
Maximum output current	20 mA

Table 233: Output 1 output signal and maximum current



#### Possible low output voltage

Output voltage may drop **down to 3.5 V** under full load.

### Opto-isolated outputs Out 2 and Out 3

**Out 2** (pin 12) and **Out 3** (pin 5) signals are optically isolated and require the user to provide a voltage level at **Isolated Out Power**.

An example of the functional circuit is indicated in [Table 85](#) on page 283.

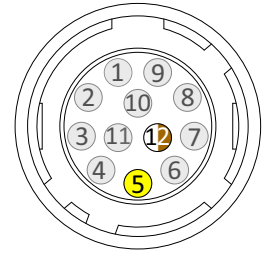

Signal	Output
Possible voltage source OutV <sub>CC</sub> Range	3 V to 30 V
Maximum output current per output	20 mA

Table 234: Output 2/Output 3 voltage source and current per channel



#### Possible low output voltage

Output voltage may drop **by 2.5 V** under full load.

The opto-isolated inputs can be connected directly to the system for voltages up to 24 VDC. An external resistor is not necessary.

#### Isolated output block diagram

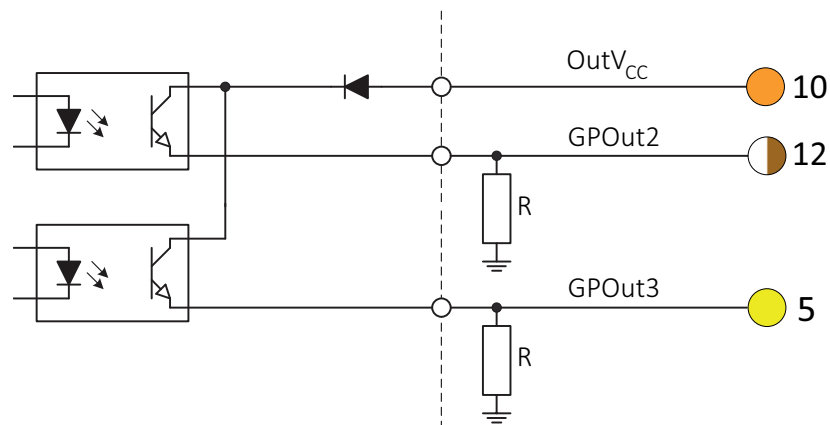

Figure 85: Goldeye G/CL isolated output block diagram

OutV <sub>CC</sub>	Resistor value
5 V	1.0 kΩ
12 V	2.4 kΩ
24 V	4.7 kΩ

Table 235: OutV<sub>CC</sub> and value of the external resistor

### Goldeye G/CL isolated output delay

The output switching times displayed in [Figure 86](#) are applicable to opto-coupled outputs only.

Note that higher external resistor values increase the time values that are listed in [Table 236](#).

Parameter	Value
Delay time	$t_d \approx 1 \mu\text{s}$
Rise time	$t_r \approx 1 \mu\text{s}$
Turn-on time	$t_{on} = t_d + t_r \approx 2 \mu\text{s}$
Storage time	$t_s \approx 26 \mu\text{s}$
Fall time	$t_f \approx 21 \mu\text{s}$
Turn-off time	$t_{off} = t_s + t_f \approx 47 \mu\text{s}$

Table 236: Output parameters and values

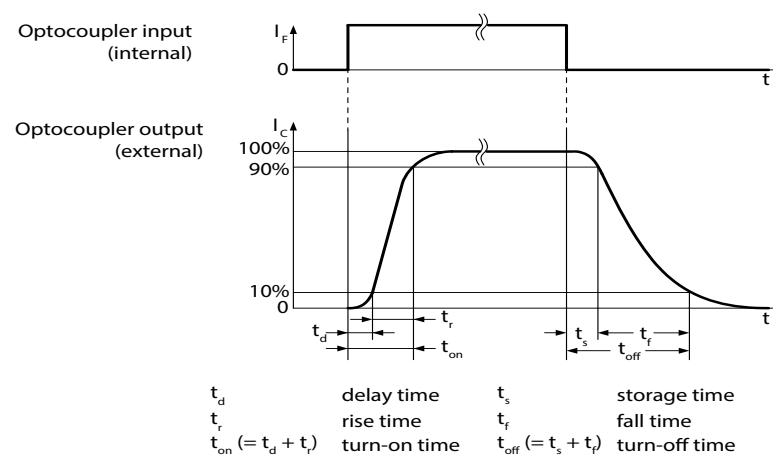

Figure 86: Goldeye G/CL output switching times



#### Cycle delay

The cycle delay for the Goldeye is as follows:

- $t_{pdLH} < 3.5 \mu\text{s}$
- $t_{pdHL} < 30 \mu\text{s}$

For this reason, we recommend triggering on the rising edge. This ensures the fastest possible reaction time.

#### Test conditions

- External 2.4 k $\Omega$  resistor to GND
- Power input for output ports set to 12 V

## Control signals

It is possible to configure the I/Os of the camera, using software. The different modes are described on the following pages.

### Inputs

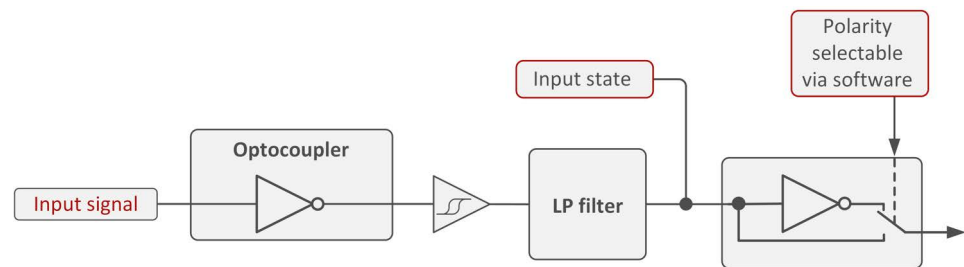

Figure 87: Goldeye G/CL input signal block diagram

### I/O pin control

All I/O signals running over the camera I/O connector are controlled by the I/O strobe commands. For more details see the Goldeye G/CL Features Reference.

### Outputs

It is possible to configure the output signals, using software. Each of the signals explained in [Table 237](#) can be routed to an output signal through a multiplexer.

Source signal	Description
GPO	Configured to be a general-purpose output, control of which is assigned to LineOutLevels.
AcquisitionTriggerReady	Active when the host application has recognized the camera, and the camera is ready to start acquisition.
FrameTriggerReady	Active when the camera is in a state that accepts the next frame trigger.
FrameTrigger	Active when an image has been initiated to start. This is a camera-internal logic trigger, which is initiated by an external trigger or software trigger event.
Exposing	Active for the duration of sensor exposure.
FrameReadout	Active during frame readout, for example, the transferring of image data from the CCD to camera memory.
Imaging	High when the camera image sensor is either exposing and/or reading out data.
Acquiring	Active during an acquisition stream.
LineIn1	Active when there is an external trigger at LineIn1.
LineIn2	Active when there is an external trigger at LineIn2.

Table 237: Goldeye G/CL possible sources for output signals (sheet 1 of 2)

Source signal	Description
Strobe1	The output signal is controlled according to Strobe1 settings.
CC1	<b>(Camera Link models only)</b> active if trigger is detected on CC1. The CC1 output acts the same way all other Goldeye outputs do.
CC2	<b>(Camera Link models only)</b> active if trigger is detected on CC2. The CC2 output acts the same way all other Goldeye outputs do.
CC3	<b>(Camera Link models only)</b> active if trigger is detected on CC3. The CC3 output acts the same way all other Goldeye outputs do.
CC4	<b>(Camera Link models only)</b> active if trigger is detected on CC4. The CC4 output acts the same way all other Goldeye outputs do.

Table 237: Goldeye G/CL possible sources for output signals (sheet 2 of 2)

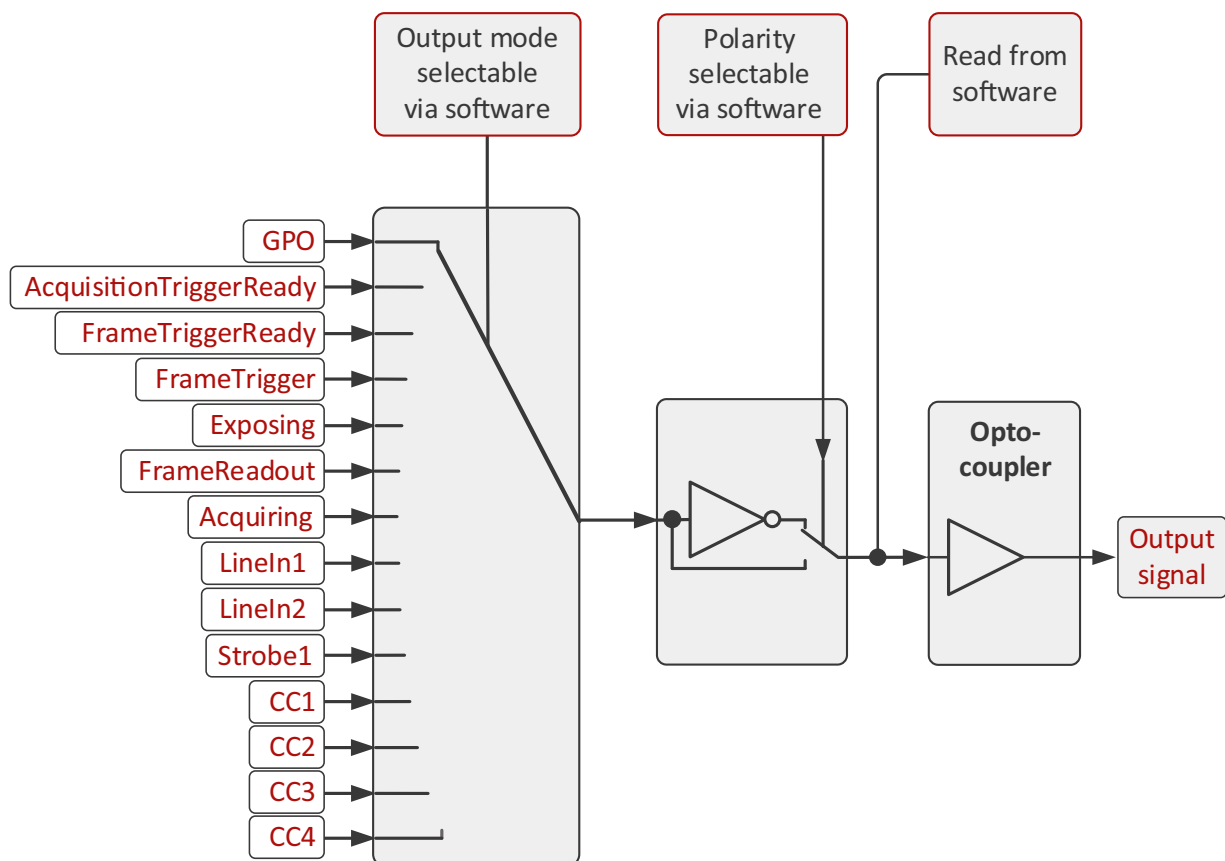

Figure 88: Goldeye G/CL signals output block diagram

## Frame grabber requirements (CL)

You can use basically any Camera Link Base compatible frame grabber to operate Goldeye CL cameras. However, the following general aspects should be considered for frame grabber selection:

- The frame grabber needs to support the individual pixel clock frequency of the camera (which may be up to 85 MHz, depending on the model). See also [Changing the clock frequency on page 288](#).
- The frame grabber and the host system need to support the pixel data bandwidth delivered by the camera.

Depending on model and operation mode, a Camera Link Base camera may be able to output up to approximately 170 million 12-bit pixels per second. Assuming a worst-case scenario of unpacked 16 bits per pixel transfer over the host bus, this results in 340 million bytes per second. This is approximately three times the bandwidth of a Gigabit Ethernet port.

- Host software design and system architecture usually affect frame grabber selection as well, for instance the number of cameras connected to the host, the different types of cameras connected, or the availability of a frame grabber specific GenICam transport layer.
- A high transmission rate support (> 115 200 bits per second) of the Camera Link serial port is recommended to improve responsiveness of host software.



### More information about frame grabbers

For more information about compatibility of various frame grabber models and system installation refer to the following sources.

- [Installing the camera \(CL\) on page 243](#)
- The application note Usage of Frame grabbers with Goldeye CL Cameras is available for download on the Allied Vision website: [www.alliedvision.com/en/support/technical-documentation/goldeye-gcl-documentation](http://www.alliedvision.com/en/support/technical-documentation/goldeye-gcl-documentation)

## Timing (CL)

All Goldeye CL models provide the possibility to adapt the timing parameters of the camera.

The timing of the data transfer is based on the Camera Link pixel clock frequency as well as on enable signals defined in the Camera Link protocol. Selecting a lower clock frequency and extending the gaps between the FVAL and LVAL enable signals help to avoid bit errors in data transfer. Therefore, it may allow to extend the usual cable length or to use less expensive cables.

### Changing the clock frequency

Goldeye CL models support several clock frequencies. [Table 238](#) displays available clock frequencies by model:

Models	Frequency			
	25 MHz	40 MHz	55 MHz	85 MHz
CL-008	✓	✓	N.a.	N.a.
CL-030	✓	N.a.	✓	✓
CL-032	✓	✓	N.a.	N.a.
CL-033	✓	N.a.	✓	✓
CL-034	✓	N.a.	✓	✓
CL-130	✓	N.a.	✓	✓

*Table 238: Possible clock frequencies with all Goldeye CL camera models.*

The clock frequency has an impact on the maximum frame rate, see the frame rate tables in [Specifications \(CL models\)](#) on page 112.



## Adjusting the gaps

Besides the Camera Link clock frequency, there are four parameters available that can be used for timing control. These parameters affect the gaps between the FVAL and LVAL signals.

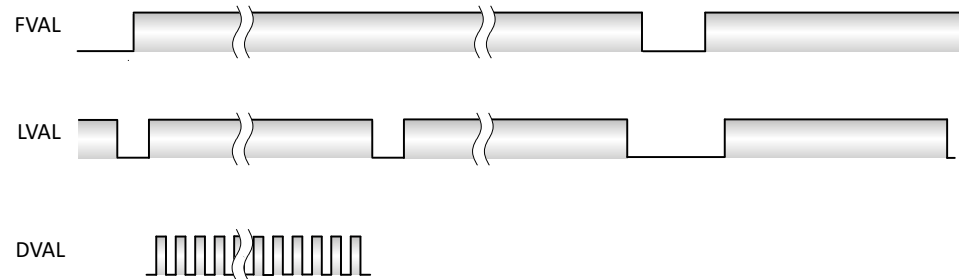

Figure 89: Principle of Camera Link data transfer

### Frame Valid (FVAL)

The synchronization signal FVAL is used to indicate the frame transfer phase. When rising, it indicates the start of a new frame transfer phase. When falling, it indicates the end of the frame transfer.

Every frame includes a certain number of lines. All lines transferred during this time slot are valid.

### Line Valid (LVAL)

The synchronization signal LVAL is used to indicate a line transfer phase within the current frame transfer. When rising, it indicates the start of a new line transfer phase. When falling, it indicates the end of the line transfer phase.

The LVAL signal is valid only while FVAL is high.

### Data Valid (DVAL)

The synchronization signal DVAL is used to indicate a valid pixel within the current line transfer phase. The DVAL bit is high for the transfer of one pixel. When high, it indicates that the pixel is valid. If low, the pixel must be ignored. A pixel is only valid, if all of the FVAL, LVAL and DVAL signals are high.

To make use of the DVAL signal, the frame grabber in use must be able to process it.

## Sequential overview

After the start of the data transfer, frames and lines are transferred using the sequence as described.

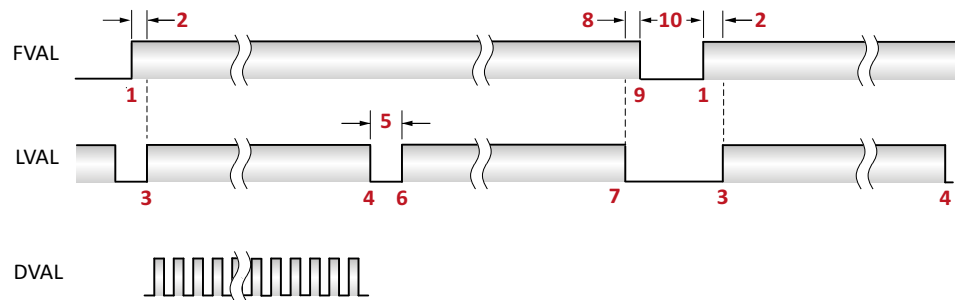

Figure 90: Camera Link data transfer

1. The FVAL signal is set to **high** and indicates the start of a new frame transfer.
2. A gap occurs before the LVAL signal is set to **high**.  
The length of this gap is controlled by the `C1MinFValToLValDelay` parameter and is given in camera clock cycles.  
The effective length of this gap is equal to either the value of `C1MinFValToLValDelay`, or  $(3 \times \text{Width} + 32)$  clock cycles, whatever is the larger.
3. The LVAL signal is set to **high** and indicates the start of a new line transfer.
4. The LVAL signal switches back to **Low** and indicates transfer of the line is complete.
5. A gap occurs between two line transfers.  
The length of this gap is controlled by the `C1LValToLValDelay` parameter and is given in clock cycles.



### Keeping gaps of equal length

If the value for `C1LValToLValDelay` is set too small, the camera may not be able to provide the data fast enough. In this case, the camera automatically extends the gap. This may result in line gaps of unequal lengths.

1. The LVAL signal is set to **high** and indicates the start of a new line transfer.
2. The LVAL signal switches back to **Low** and indicates transfer of the line is complete.  
If this was not the last line, go to #5.  
If this was the last line, go to #8.
3. A gap occurs after the last line transfer within a frame.  
The length of this gap is controlled by the `C1LValToFVal` parameter and is given in clock cycles.
4. FVAL switches back to **Low** and indicates the transfer of the frame is complete.
5. A gap occurs between two frame transfers.  
The Length of this gap is controlled by the `C1MinFValToFVal` parameter and is given in clock cycles.  
Note that this is the minimum delay that must be kept between two frames.  
Go to #1.

Figure 91 shows how gaps between the FVAL and the LVAL signals can be adjusted. The lengths of the gaps can be adjusted using the features listed in Table 239.

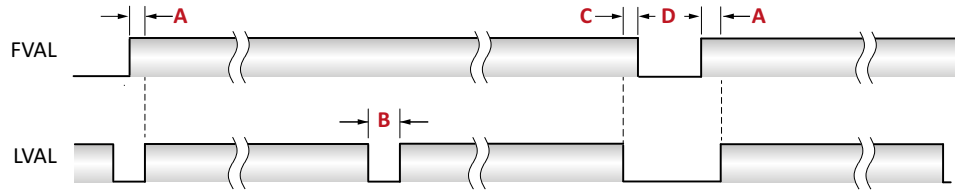

Figure 91: Gaps usable for Goldeye CL timing control

Gap	Description	Length [clock cycles]		
		Min.	Default	Max.
A	Minimum gap between the rising edges of the FVAL signal and the first line's LVAL signal. The real delay may be higher than the value specified with this feature. Feature name: <code>C1MinFvalToLvalDelay</code>	0	32	1023
B	Width of the line gap. Feature name: <code>C1LvalToLvalDelay</code>	1	64	1024
C	Gap between the falling edges of the last lines' LVAL signal and the FVAL signal. Feature name: <code>C1LvalToFvalDelay</code>	0	32	1024
D	Minimum gap from one falling edge to the next rising edge of the FVAL signal. The real value may be higher than the value specified by this feature. Feature name: <code>C1MinFvalToFvalDelay</code>	1	32	1024

Table 239: Gaps usable for Goldeye CL timing control

## Starting the acquisition automatically (CL)

To start the acquisition automatically after the camera powers up, follow these steps:

- Step 1: Go to the `AcquisitionAutoStartMode` feature and set it to *On*.
- Step 2: Select a user set, using the `UserSetSelector` feature.
- Step 3: Save the current camera parameters in the selected user set, using the `UserSetSave` feature.
- Step 4: To set the selected user set as default user set that will be active after the next start of the camera, activate it using the `UserSetLoad` feature.
- Result: Now the camera will start the acquisition automatically after the next power-up.

# Triggering



This chapter includes:

Trigger timing diagram .....	293
Trigger rules .....	294
Trigger latencies and jitter .....	294

## Trigger timing diagram

The diagram in [Figure 92](#) explains the trigger concept in general.

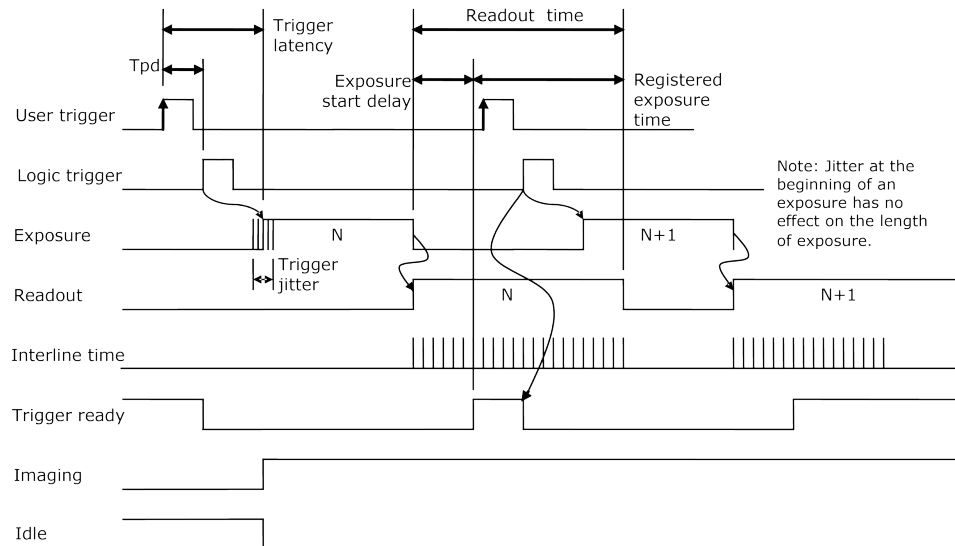

Figure 92: Goldeye G/CL trigger timing diagram

For trigger descriptions on camera control basis see the Allied Vision GigE Camera and Driver Features document.

## Trigger definitions

Term	Definition
User trigger	Trigger signal applied by the user (hardware trigger, software trigger).
Logic trigger	Trigger signal seen by the camera internal logic (not visible to the user).
Tpd	Propagation delay between the User trigger and the Logic trigger.
Exposure	High when the camera image sensor is integrating light.
Readout	High when the camera image sensor is reading out data.
Trigger latency	Time delay between the user trigger and the start of exposure.
Trigger jitter	Error in the trigger latency time.
Trigger ready	Indicates to the user that the camera is ready to accept the next trigger.
Registered exposure time	Exposure time value currently stored in the camera memory.
Exposure start delay	Registered Exposure Time subtracted from the Readout time. Exposure start delay indicates when the next exposure cycle can begin such that the exposure end after the current Readout.
Interline time	Time between sensor row readout cycles.
Imaging	High when the camera image sensor is either exposing and/or reading out data.
Idle	High if the camera image sensor is not exposing and/or reading out data.

Table 240: Goldeye G/CL trigger definitions

## Trigger rules



### Application notes: Triggering concept for GigE camera (advanced)

For a more detailed description of the trigger concept for advanced users and special scenarios, see [www.alliedvision.com/en/support/faqs-application-notes](http://www.alliedvision.com/en/support/faqs-application-notes):

- Triggering concept for Allied Vision GigE cameras
  - Using ITR and IWR mode to maximize the frame rate of Goldeye cameras.
1. The **user trigger pulse width** should be at least three times the width of the trigger latency.
  2. The **end of exposure** always triggers the next Readout.
  3. The **end of exposure** must always end after the current Readout.
  4. The **start of exposure** must always correspond with the Interline Time if Readout is true.
  5. **Exposure start delay** is equal to the Readout time less the Registered Exposure Time.

## Trigger latencies and jitter

### Goldeye models except G/CL-x30 TEC1

#### Triggering during the idle state

To minimize the trigger latency and trigger jitter, the user trigger signal should be applied when Imaging is false and Idle is true. [Table 241](#) shows possible values:

Trigger latency on LineIn1 (TTL)	0.6 $\mu$ s (max.)
Trigger latency on LineIn2 (opto-isolated)	3.5 $\mu$ s (max.)
Trigger jitter on both LineIn1 and LineIn2	1 pixel (max.)

*Table 241: Trigger timings during the idle state (except G/CL-x30 TEC1)*

#### Triggering during the readout state

To achieve the fastest triggering cycle time during which the camera image sensor is exposing and reading out simultaneously, the User trigger signal should be applied as soon as a valid trigger Ready is detected. [Table 242](#) shows possible values:

Trigger latency on LineIn1 (TTL)	1 line (max.) + 0.6 $\mu$ s (max.)
Trigger latency on LineIn2 (opto-isolated)	1 line (max.) + 3.5 $\mu$ s (max.)
Trigger jitter on both LineIn1 and LineIn2	1 pixel (max.)

*Table 242: Trigger timings during the readout state (except G/CL-x30 TEC1)*

## Goldeye G/CL-x30 TEC1 models

Trigger timings during the idle state and readout state are the same for these models.

### Trigger timings for Goldeye G/CL-030 TEC1

Values in [Table 243](#):

- Line time for Mono8: 7.7  $\mu$ s
- Line time for Mono12: 13.25  $\mu$ s
- Delays can last for 1 line or 2 lines, depending on the conditions.
- +0.6  $\mu$ s maximum offset = 0  $\mu$ s to +0.6  $\mu$ s.

Parameter	Description Lines + offset	Value ranges	
		Mono8	Mono12
Trigger latency on LineIn1 (TTL)	2 lines (max.) +0.6 $\mu$ s (max.)	7.7 $\mu$ s to 16.0 $\mu$ s	13.25 $\mu$ s to 27.1 $\mu$ s
Trigger latency on LineIn2 (opto-isolated)	2 lines (max.) +3.5 $\mu$ s (max.)	7.7 $\mu$ s to 18.9 $\mu$ s	13.25 $\mu$ s to 30.0 $\mu$ s
Trigger jitter on both LineIn1 and LineIn2	1 line (max.)	7.7 $\mu$ s	13.25 $\mu$ s

Table 243: Trigger timings for Goldeye G/CL-030 TEC1

### Trigger timings for Goldeye G/CL-130 TEC1

Values in [Table 244](#):

- Line time for Mono8: 10.05  $\mu$ s
- Line time for Mono12: 13.25  $\mu$ s
- Delays can last for 1 line or 2 lines, depending on the conditions.
- +0.6  $\mu$ s maximum offset = 0  $\mu$ s to +0.6  $\mu$ s.

Parameter	Description Lines + offset	Value ranges	
		Mono8	Mono12
Trigger latency on LineIn1 (TTL)	2 lines (max.) +0.6 $\mu$ s (max.)	10.05 $\mu$ s to 20.7 $\mu$ s	13.25 $\mu$ s to 27.1 $\mu$ s
Trigger latency on LineIn2 (opto-isolated)	2 lines (max.) +3.5 $\mu$ s (max.)	10.05 $\mu$ s to 23.6 $\mu$ s	13.25 $\mu$ s to 30.0 $\mu$ s
Trigger jitter on both LineIn1 and LineIn2	1 line (max.)	10.05 $\mu$ s	13.25 $\mu$ s

Table 244: Trigger timings for Goldeye G/CL-130 TEC1

# Image data flow



This chapter includes:

Image data flow.....	297
Image corrections .....	298
Image processing .....	300
Automatic image control .....	302
Other image controls .....	309
Value changes by feature interdependencies .....	311



# Image data flow

The following block diagram illustrates the flow of image data within the camera. The features of the individual modules are described in detail on the following pages. Note that, depending on firmware version, not all of the modules and features shown in [Figure 93](#) are available.

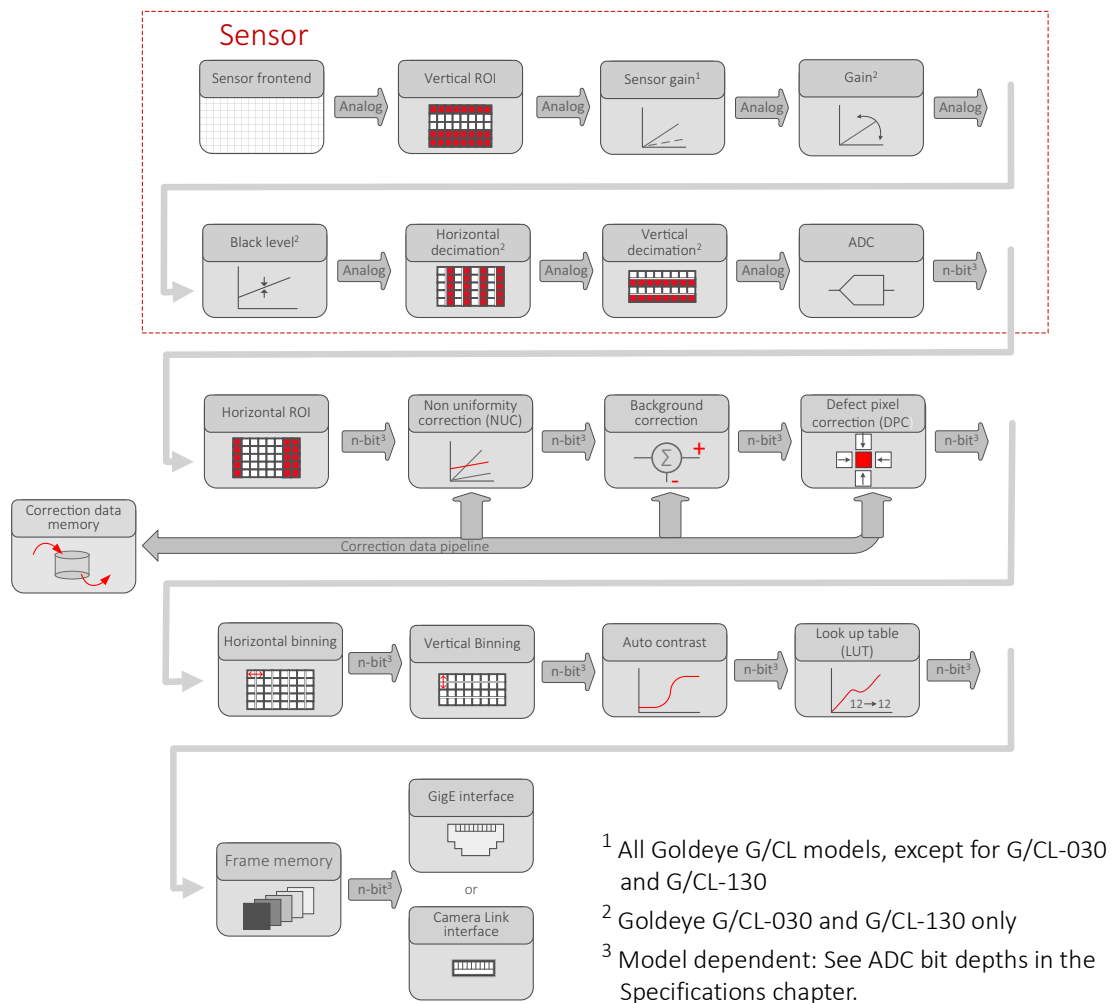

Figure 93: Goldeye G/CL image data flow

The Goldeye G/CL contains a chain of image processing modules, called the **image processing chain**. The first module (called **Analog Gain**) receives the source signal from the sensor. Each of the subsequent modules receives the output data of the previous module as input.

The behavior of each module is configurable by software via specific features. That way, it is possible to set parameters or operation modes for each module.

Each module passes on the data to the succeeding module. The output of the last module is stored in the frame memory, which in turn passes it on to the GigE or Camera Link interface for output.

## Image corrections

The corrections applied to the image are of special relevance within the Goldeye camera. They are applied by the following modules.

- Non-uniformity correction (NUC)
- Background correction (BC)
- Defect pixel correction (DPC)

The corrections need special correction data that must be provided before operating the image processing chain.

Find detailed descriptions of the features and the functionality associated with them in the Goldeye G/CL Features Reference.

## Determination and storage of correction data

For each individual camera, specific correction data is determined during the manufacturing process. All necessary correction data is stored within the camera's non-volatile flash memory ex works.

During camera start-up, the available correction data is copied from the flash memory onto the correction data memory for real time access.

From the correction data memory, the correction data is transferred to the individual correction modules. The correction data transfer is synchronized with the transfer of image data from the sensor. A correction module may also write back to the correction data memory, depending on its functionality.

The IR specific image correction modules are described in detail in the following sections.

## Non-uniformity correction

Every pixel of an InGaAs sensor possesses its individual amount of dark signal (dark signal non-uniformity, DSNU) and an individual sensitivity for light (photo response non-uniformity, PRNU). Therefore, while exposing, each sensor creates a specific, non-uniform underlying pattern. This pattern can be compensated with help of the non-uniformity correction.

To correct the non-uniformity, correction values for gain and offset of each pixel are determined based on multiple reference images and applied to the actual image. Ideally, after correction no image structure is recognizable.

However, there are various conditions that influence the image quality:

- Analog gain setting
- Sensor temperature
- Exposure time

These conditions need corresponding correction data for best correction quality. Therefore, the camera contains several data sets for a range of conditions.

Because each correction data set is applicable under certain conditions only, the relevant conditions are stored with the data set.

An automated data set selection feature keeps track of the conditions. If any of the parameters changes, the most suitable correction data set is selected automatically. No additional user interaction is necessary.

Set to **Continuous**, this function updates the data set selection for every frame.

## Background correction

The background correction is used as an additional correction, based on actual operating conditions, to optimize the result of the NUC.

The correction data for the NUC is factory-provided and based on specific conditions: exposure time, sensor temperature, and sensor gain setting. If the conditions during camera operation are different, non-uniformity correction does not work at best performance.

To compensate for remaining non-uniformity, the live image is corrected with a previously recorded dark image. This image is subtracted from the pre-corrected image to reduce the fixed pattern noise.

To adapt the BC to local conditions, customers acquire their own volatile correction image. It is also possible to shift the offset individually, if needed.

## Defect pixel correction

The pixels of InGaAs sensors may show abnormal behavior in one or more of the three characteristics:

- Dark offset
- Photo response
- Dynamic noise

The result is an excessively reduced dynamic range. These pixels are counted as defect pixels.

The value of each defect pixel is replaced by an interpolated value from non-defect neighboring pixels. This way, the image appears without disturbing bright or dark pixels.

# Image processing



## Feature descriptions

For detailed features descriptions, see the Goldeye G/CL Features Reference at [www.alliedvision.com/en/support/technical-documentation/goldeye-gcl-documentation](http://www.alliedvision.com/en/support/technical-documentation/goldeye-gcl-documentation).

## Black level

**BlackLevel1** is available only on **Goldeye G/CL-030 and G/CL-130**. **BlackLevel1** controls the DC offset applied to the video signal.

## Gain

Goldeye cameras use two different concepts to control the gain level.

Feature	Location	Available values	Unit	Supported models
Gain	Camera electronics	0 to 18 dB (float)	Dezibel	Goldeye G/CL-030, G/CL-130
SensorGain	Sensor	1 or 2 gain steps	Factor	All other Goldeye models

Table 245: Comparison between Gain and SensorGain features

## Look-up table

The use of a look-up table allows any mapping function in the form

**output = f(input)**

to be applied to the pixel values at runtime.

The factory setting of Goldeye cameras includes eight preloaded LUT files.

- Four pre-configured LUT files are available. Those files are 14-bit LSB aligned and are named from LUT\_000 to LUT\_003. The pre-configured files are not changeable in user mode.
- Four user-configurable LUT files are available. Those files are empty and are named from LUT\_User\_000 to LUT\_User\_003.

## Loading a dataset files into the volatile LUT memory

1. Select the file to be loaded with `LUTDatasetSelector`
2. Select the target LUT with `LUTSelector`
3. Call the command `LUTDatasetLoad`

The LUT will not be loaded if an empty dataset file has been selected.

To avoid temporary invalid image data, we recommend you to do one of the following before executing `LUTDatasetLoad`:

- Stop image acquisition
- Set `LUTEnable` to `False`.

## Saving a LUT from volatile memory to file

1. Select the LUT to be saved with `LUTSelector`
2. Select the target file with `LUTDatasetSelector`
3. Call the command `LUTDatasetSave`.

To avoid temporary invalid image data, we recommend you to do one of the following before changing the `LUTValue` at several index positions of a LUT:

- Stop image acquisition
- Set `LUTEnable` to *False*.

## Binning

Binning reduces the image resolution by merging the gray values of adjacent pixels, but based on the full ROI.

Different binning modes:

- *Sum* increases the sensitivity.
- *Average* can be used to reduce noise.

In all Goldeye cameras, digital binning is applied after the Background Correction. Background Correction can be used to reduce the background level to enable higher binning values.

## Decimation

### **Goldeye G/CL-030 and G/CL-130**

Decimation reduces the image resolution by omitting pixels, but based on the full ROI. In Goldeye G/CL-030 and G/CL-130 cameras, decimation is applied in the sensor module before binning.

# Automatic image control

## Definitions

To properly explain the working principle of automatic image control, the definition of several special terms is clarified first. Refer also to [Figure 94 on page 303](#).

### Accounted pixels

Once the outliers are discarded from the calculation, all pixels holding gray values in the middle of the image histogram constitute the Accounted pixels.

### Mean value

The average gray value of all accounted pixels. This means that within the accounted pixels range of the image histogram, the same number of accounted pixels is situated to either side of the mean value.

### Minimum and maximum

The smallest and the largest gray value of pixels accepted within the number of accounted pixels.

### Outliers

Outliers are defined as the brightest and darkest pixels in an image. Usually they originate from defect pixels of the sensor itself.

Small, very bright, or very dark objects in the observed scene can also create outliers. Because very small objects usually do not carry much useful scene information, they can be treated like outliers as well.

In an image histogram, the outliers show on the far-left side (dark pixels) and on the far-right side (bright pixels).

## Eliminating outliers

The calculations of all auto level control features, including the automatic exposure operation, may be influenced by outliers in an unwanted way.

The auto level control settings allow for discarding outliers and thus preventing their undesired impact on the auto level control adjustments.

- To exclude the outliers on the dark side of the histogram (left), use the **AutoModeOutliersDark** feature. To include all dark pixels into the calculations, set the feature to 0.
- To exclude the outliers on the bright side of the histogram (right), use the **AutoModeOutliersBright** feature. To include all bright pixels into the calculations, set the feature to 0.

The values for both exclusion areas do not need to be equal.

For all the calculations concerning automatic image control, only the pixels not excluded by the outlier settings are considered.

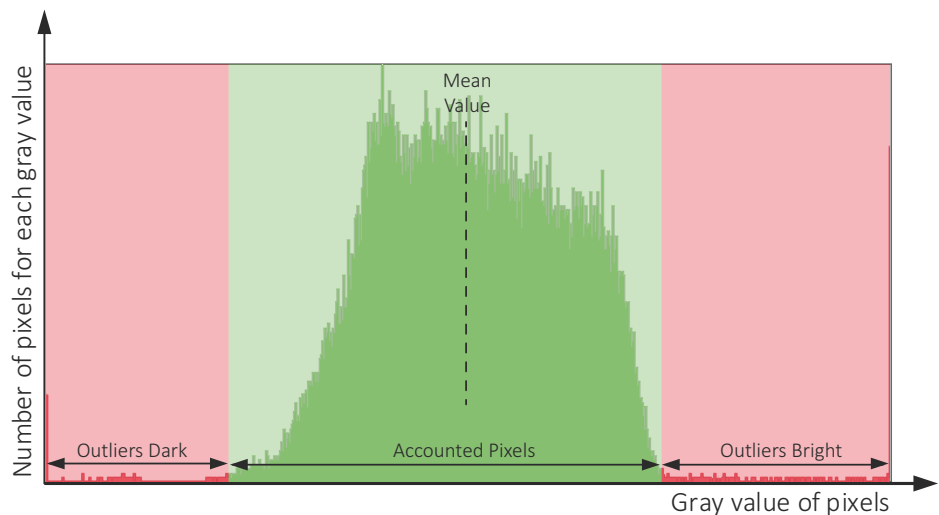

Figure 94: Image histogram showing the ranges of accounted pixels (green), the ranges of the outliers (red) and the mean value.

## Selecting an ROI

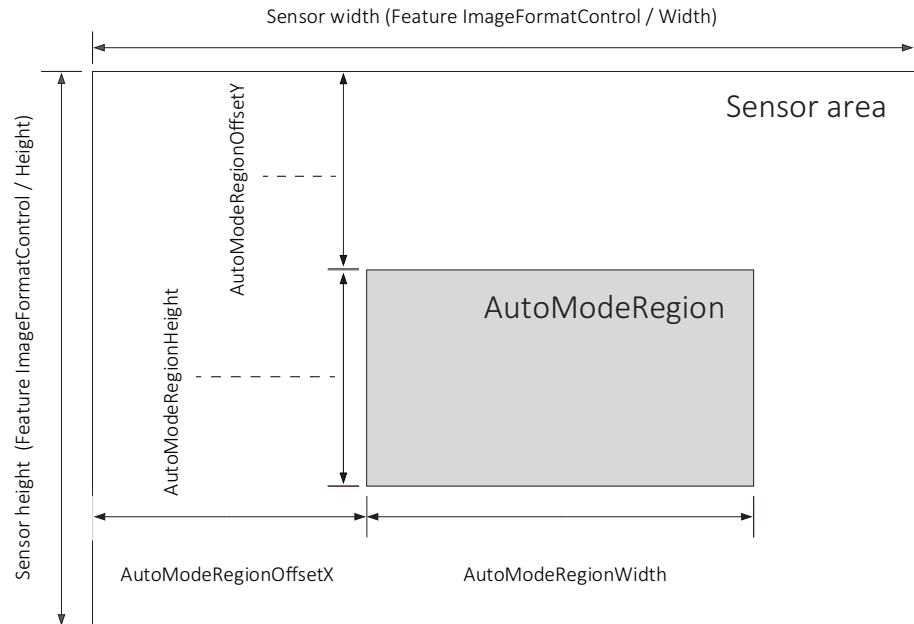

Figure 95: AutoModeRegion features

As for any other auto mode feature, you can use the **AutoModeRegion** feature and its sub-features to define the ROI. You may determine the automatic image control based on the whole sensor area or based on a defined ROI.

## Marking the defined ROI

It is possible to mark the defined ROI by dimming the area outside the ROI, so the selected area stands out brighter. To do so, set the feature **AutoModeRegionDimOutside** to *On*.



Figure 96: Example for the effect of AutoModeRegionDimOutside. Left: without dimming applied, right: with dimming applied to the outside area.



## Automatic exposure control

The exposure of the Goldeye G/CL can be adjusted automatically by applying the relevant auto exposure settings. The adjustment is based on the present signal values of pixels within the image.

By default, the automatic exposure control is switched off, however, it is possible to have the automatic exposure control run in several ways:

- Run it continuously.
- Run it until the required target value is reached, then stop it.

### Selecting an algorithm

To automatically determine the optimal exposure of the sensor, a few statistical values need to be calculated first: a mean (average) value, minimum and maximum values. These values are calculated with the help of the histogram of the last captured image.

The camera provides two different behaviors to control auto exposure. Use the settings of the `ExposureAutoAlg` feature to select the desired behavior.

#### Operating the automatic exposure based on the mean value

Set the `ExposureAutoAlg` feature to *Mean*, and set the `ExposureAutoTarget` feature to the desired value.

In this case, the automatic exposure control loop is aimed at keeping the mean value of the image histogram equal to the value set by `ExposureAutoTarget`.

The value for `ExposureAutoTarget` needs to be specified in percentage from the full dynamic range, including the outliers' areas. Higher values of `ExposureAutoTarget` will cause longer exposure times, thus result in brighter images, lower values cause shorter exposure times, thus result in darker images.

If this value is set to 40 percent, then 40 percent of all pixels of the image are darker and 60 percent of all pixels of the image are brighter than this value.

#### Operating the automatic exposure based on the full range of values

Set the `ExposureAutoAlg` feature to *FitRange*. The `ExposureAutoTarget` feature has no influence in this case.

In this case, the automatic exposure control loop regulates the exposure in such a way that the maximum value of the image histogram is kept close to the upper end of the dynamic range of the camera.

## Tolerance

If the automatic exposure is calculated for every frame (`ExposureAuto = Continuous`), most likely there are minuscule adjustments to be applied to each frame. These adjustments may cause certain, though usually insignificant, variations of the image brightness between consecutive frames.

To prevent these adjustments, the feature `ExposureAutoAdjustTo1` can be used.

The exposure is adjusted only if the current regulated value deviates from the ideal target value by more than a given percentage.

## Slowing down the auto exposure adjustments

By default, the automatic exposure adjustments run at 20% speed<sup>1</sup>. Using the `ExposureAutoRate` feature, you can increase or decrease the automatic exposure adjustments to a fraction of the maximum possible speed. This can be useful for some applications and sensor settings, to prevent the auto exposure control loop from occurring oscillations.

<sup>1</sup>20% as default applies from firmware V02.22.X. Previous versions have this parameter set to 100%.

## Contrast control

By default, `Contrast` is disabled. Contrast can be set manually by the user or automatically.

### Manual mode

- Values for `ContrastUserInputMin / ...Max` are set by the user.
- `ContrastAuto=UserWholeImage` and `ContrastAuto=UserModeAutoRegion` are available.

### Automatic mode

- Values for `ContrastUserInputMin / ...Max` are obtained from an internal histogram that is based on the current image data.
- `ContrastAuto=WholeImage` and `ContrastAuto=AutoModeRegion` are available.

## Setting Contrast for the whole image or for an ROI

Automatic contrast control uses the input range defined by **ContrastUserInputMin** and **ContrastUserInputMax**. It can be applied:

- To the whole image. The input range of the contrast is automatically determined from the image data.
- To a defined ROI. To apply the automatic contrast to a ROI, use the **AutoModeRegion** features to define the area.



*Figure 97: Left: auto contrast applied to ROI, right: auto contrast applied to the whole image.*

This formula describes the pixel transfer function to calculate the contrast:

$$\text{pixel\_tmp} = \frac{(\text{pixel\_in} - \text{min\_in}) \times (\text{ContrastAutoIntensityMax} - \text{ContrastAutoIntensityMin})}{(\text{max\_in} - \text{min\_in})} + \text{ContrastAutoIntensityMin}$$

Clipping:

$$\text{pixel\_out} = \max(\min(\text{pixel\_tmp}, \text{pixeldata\_max}), 0)$$

Where

- **min\_in** and **max\_in** are defined by **ContrastUserInputMin** and **ContrastUserMax** in **UserWholeImage** and **UserAutoRegionMode**. In **WholeImage** and **AutoModeRegionMode**, **min\_in** and **max\_in** are calculated automatically from the image data.
- **pixel\_in** and **pixel\_out** refer to the same pixel location in the input and output image of the contrast calculation.

## Controlling the intensity of contrast

Using the `ContrastAutoIntensity` features, it is possible to adjust the intensity of contrast applied. Those features represent an upper and lower threshold of contrast intensity. In combination, they act as follows:

- If both features are set to higher values, the affected area of the image turns brighter.
- If both features are set to lower values, the affected area of the image turns darker.
- If the difference between the set values for both features increases, contrast intensity increases (the black and white spots within the affected area are increasing in number).
- If the difference between the set values for both images decreases, contrast intensity decreases (the gray spots within the affected area are increasing in number).
- The image is turned into its negative if `ContrastAutoIntensityMin` is set to a higher value than `ContrastAutoIntensityMax`.



*Figure 98: Left: Auto contrast applied to a ROI in the usual way, right: auto contrast with the `ContrastAutoIntensity` values reversed.*

## Other image controls

### Frame memory

Goldeye cameras capture and transmit each image in consecutive steps. The image is taken, read out from the sensor, digitized, and transmitted to the host computer over the connection used, either Camera Link or Gigabit Ethernet.

For buffering the frames before transmission, a certain amount of RAM is available. The number of frames in the frame memory depends on the defined ROI and the pixel format. [Table 246](#) shows the memory size and the number of frames (StreamHoldCapacity) that can be stored by each model.

Model <sup>1</sup>	Memory size and frames stored	Pixel format and resolution
G/CL-008	256 MB memory: 1524 frames	Mono14, full resolution
G/CL-030	256 MB memory: 370 frames	Mono12, full resolution
G/CL-032	256 MB memory: 397 frames	Mono14, full resolution
G/CL-033	256 MB memory: 392 frames	Mono14, full resolution
G/CL-034	256 MB memory: 392 frames	Mono14, full resolution
G/CL-130	256 MB memory: 95 frames	Mono12, full resolution

<sup>1</sup> Including Cool, TECless, TEC1, TEC2, or XSWIR where applicable

Table 246: Typical image memory size

## Trigger-induced distortion correction

### Background

The trigger-induced distortion (TID) is an image artifact that originates from an influence of the external trigger. The TID occurs only if the two following conditions are met:

- The camera runs in IWR mode.
- The time between the readout of two consecutive frames is smaller than the sum of readout time and exposure time.



#### Application note: Using ITR and IWR mode

For details how to use ITR and IWR mode in Goldeye Cameras an application note Using ITR and IWR mode to maximize the frame rate of Goldeye Cameras is available online:

[www.alliedvision.com/en/support/technical-documentation/goldeye-gcl-documentation](http://www.alliedvision.com/en/support/technical-documentation/goldeye-gcl-documentation)

The TID can cause a vertical line glitch and a horizontal step in brightness. The magnitude of both depends on the camera model and the selected **SensorGain**.

## Controlling the trigger-induced distortion

You can control both artifacts by the **TIDC\_Mode** feature. It allows to correct both distortions at the same time, or separately. The correction for both distortions is switched on by default. You find the feature under **DeviceControl1 > SensorBoardSettings > TriggerInducedDistortionCorrection**.

For technical reasons the line glitch correction is disabled or enabled automatically depending on the image width. For details see [Table 247](#).

	<b>G/CL-008</b>	<b>G/CL-030</b>	<b>G/CL-032</b>	<b>G/CL-033</b>	<b>C/CL-034</b>	<b>G/CL-130</b>
When <b>decreasing</b> image width, the line glitch correction is <b>disabled</b> from this ROI width on:	152	N.a.	302	288	288	N.a.
When <b>increasing</b> image width, the line glitch correction is <b>enabled</b> from this ROI width on:	154	N.a.	304	290	290	N.a.

*Table 247: Activation and deactivation of the TIDC depending on ROI width*

# Value changes by feature interdependencies

The conversion between time and clock cycles affects control values. Features for pixel format, bandwidth, ROI, exposure time, and triggering are related to each other. Changing values for one feature can change values for another feature. For example, frame rates can be reduced when `PixelFormat` is changed subsequently. [Figure 99](#) shows the interdependencies.

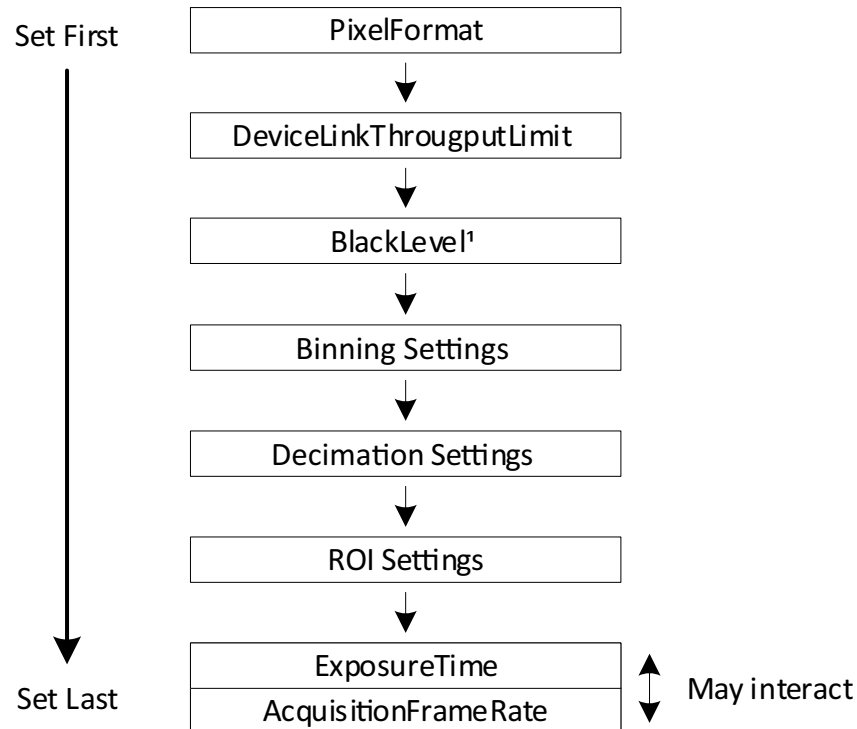

<sup>1</sup> Goldeye G/CL-030 TEC1 and G/CL-130 TEC1 only

Figure 99: Interdependencies between features

## Effects for the interdependent features

Changing one control's value affects other control's values, such as:

If: `Height` value is changed.

Then: Other values may be affected, such as for `AcquisitionFrameRate` and `ExposureTime`.

We recommend you to consider:

- The more features you adjust, the more current values deviate from previously set values.
- The same effects that apply to `ExposureTime`, also apply to `AutoExposure`.
- To avoid readjustments, apply settings in the order shown in [Figure 99](#).

# Temperature control



This chapter includes:

How temperature affects the sensor.....	313
TEC1, TEC2, TECless .....	313
Warm-up period with TEC1 and TEC2 .....	315
Additional heating for selected models.....	315
Neutralization of the temperature influence .....	317
Operational statuses .....	325
Features for temperature control .....	326





### CAUTION

#### Risk of burns

The camera housing may heat up during operation. Touching the camera with bare hands may lead to injuries.

Wear protective gloves when touching a heated-up camera during operation. Also, use proper heat dissipation methods to keep the camera as cool as possible.

## How temperature affects the sensor

During operation, the electronics heat up the camera interior and housing. InGaAs sensors are affected by temperature in two ways:

#### 1. Absolute level of sensor temperature

An increase in sensor temperature reduces the image quality, because:

- An increased sensor temperature increases the dark current of the FPA's photo-diodes, thus decreasing the dynamic range of the camera. As a rule of thumb, a temperature increase of 8 Kelvin doubles the dark current. The dark current produces additional offset and noise, especially at longer exposure times, which causes a decrease in image contrast.
- The spectral sensitivity may change: A difference in temperature may cause the sensitivity curve to drift or to become slightly narrower.
- Certain components of the InGaAs sensor are prone to temperature drift. A drop in temperature causes a shift of the spectral sensitivity of 25 nanometers toward the lower wavelengths.

#### 2. Fluctuation of sensor temperature

If the temperature influence on the sensor remains constant, the image quality is high. To achieve this, TEC1 and TEC2 stabilize the sensor temperature at one of several defined temperature setpoints.

For the Goldeye stabilized and cooled models, three or four setpoints are defined, depending on the camera model.

To optimize image quality, the temperature can be stabilized by:

- Temperature control of the sensor,
- Neutralization of the temperature influence.

This chapter describes how temperature control is realized on Goldeye cameras.

## TEC1, TEC2, TECless

Model suffix	Cooling type	Reference
TEC1	Single-stage thermo-electric cooling	314
TEC2	Dual-stage thermo-electric cooling	314
TECless	Passive camera cooling	314

Table 248: Temperature control types overview

## TEC1

**Single-stage thermo-electric cooling** (TEC1) is an active cooling technology that keeps the sensor at a stable temperature that is as low as possible. The specially designed Goldeye housing dissipates the heat build-up inside the camera and radiates the heat into the environment

## TEC2

**Dual-stage thermo-electric cooling** (TEC2) allows you to operate the sensor at a temperature well below ambient temperature. This allows for keeping a higher image quality even with longer exposure times. However, with low sensor temperatures and a larger difference to ambient temperatures, condensation on the sensor is likely to occur. To avoid condensation, every TEC2-cooled sensor is placed inside a nitrogen-filled chamber.

In addition to temperature stabilization, Goldeye Cool cameras are equipped with a fan to actively dissipate the heat that builds up internally.

Note that the housing size design is independent from the implemented thermo-electric cooling. A Cool model does not necessarily have TEC2.

See [Neutralization of the temperature influence](#) on page 317 for a detailed explanation.

## TECless

**Passive cooling** (TECless) provides no active temperature stabilization for the sensor. TECless models are especially suitable for environments with a low and stable ambient temperature, or in application scenarios where the influence of temperature on image quality is limited, for example, at low exposure times below 10 milliseconds.

### Recommended environment for Goldeye TECless

Goldeye TECless models are not equipped with a TEC element, hence the camera does not possess temperature setpoints and cannot stabilize the sensor temperature. Therefore, TECless models are recommended to be run in an environment with stable temperature and humidity.

Their non-uniformity correction sets are calibrated for a sensor temperature of +45 degrees Celsius, because this is the sensor temperature that most likely is to be expected when the camera is operated at an ambient temperature of 23 degrees Celsius and a relative humidity of 40 percent.

## Warm-up period with TEC1 and TEC2

After switching on the camera, the TEC stabilizes the sensor temperature at the default setpoint, if possible. Optimum image quality is reached within one minute.

**Goldeye G/CL-008, G/CL-030, and G/CL-130** models are also able to heat up the sensor to any temperature within the operating temperature range. See [Additional heating for selected models](#) on page 315.

A red flashing temperature status LED indicates the warm-up period.

A steady green temperature status LED indicates the **Stable** temperature state.



### Use a heat sink to reduce camera temperature

To improve the cooling capability of the Goldeye stabilized and TECless models, a heat sink set is available that can be mounted to the camera by the customer. Up to four heat sinks can be fitted to one camera.

The heat sink set is available from Allied Vision, product code 1068300.



### Application note: Usage of Heat Sinks with Goldeye Cameras

This application note explains the handling of heat sinks with Goldeye cameras and lists additional methods to improve camera cooling:

[www.alliedvision.com/en/support/technical-documentation/goldeye-gcl-documentation](http://www.alliedvision.com/en/support/technical-documentation/goldeye-gcl-documentation)

## Additional heating for selected models

The TEC1 element of a camera usually can only cool the sensor. In addition to that, **Goldeye G/CL-008, G/CL-030, and G/CL-130** models use the TEC1 element to heat the sensor. This ability has the following advantages:

- The camera can operate at a sensor temperature that is higher than the ambient or housing temperature.
- When used for low-temperature applications, if the ambient temperature is far below +20 degrees Celsius, or if the default temperature setpoint has been set high above the ambient temperature, the warm-up period is considerably shortened. Even in ambient temperatures below 0 degrees Celsius, the camera reaches a stable temperature within one minute.
- The heating capability prevents any variation of the sensitivity curve caused by fluctuation of temperature.

## Activating the heating of Goldeye G models

After activating the heating of **Goldeye G-008, G-030, and G-130**, switching down to a setpoint below the selected setpoint is disabled. The ability to switch to a higher setpoint depends on the `SensorTemperatureSetpointMode` feature:

- If set to *Auto*, the camera is able to switch to a higher setpoint, if it exists.
- If set to *Manual*, the camera is not able to switch to any other setpoint.

To activate the heating of the camera, follow these steps:

Step 1: Set the `SensorTemperatureTargetSetpoint` feature to the desired target setpoint.

Step 2: Set the `SensorTemperatureControlMode` feature to *TemperatureControlTarget*.

## Activating the heating of the CL models

After activating the heating of **Goldeye CL-008, CL-030, and CL-130**, switching down to a setpoint below the selected setpoint is disabled. The ability to switch to a higher setpoint, depends on the `RegSensorTemperatureSetpointMode` register:

- If set to *Auto*, the camera is able to switch to a higher setpoint, if it exists.
- If set to *Manual*, the camera is not able to switch to any other setpoint.

To activate the heating of the camera, follow these steps:

Step 1: Set the `RegSensorTemperatureTargetSetpoint` register to the desired target setpoint.

Step 2: Set the `RegSensorTemperatureControlMode` register to *TemperatureControlTarget*.



### Reducing power consumption of the camera

Reducing the camera's operating temperature can reduce its typical power consumption significantly for any given temperature setpoint.

The TEC works more efficiently if the temperature difference between the cool side and the warm side of the TEC is decreased.



### Unexpected shutdown of Goldeye Cool models

Goldeye Cool cameras are shut off automatically if the specified maximum operating temperature is exceeded. This can happen when the cover fan outlet is blocked.

Enable a free air flow for the fan outlet on the camera top.

# Neutralization of the temperature influence

To control the temperature influence on the non-uniformity, the TEC element keeps the sensor temperature at predefined setpoints, preferably the default setpoint.

## Temperature setpoints

A set of correction data is applied to the output signal. This correction data set is predetermined for each camera individually and is optimized for the default temperature setpoint. The correction data set is uploaded into the camera during manufacturing.

Models	Setpoint 1	Setpoint 2	Setpoint 3	Setpoint 4
G/CL-008 TEC1	+20 °C <sup>1</sup>	(Default) +25 °C	+35 °C	+50 °C
G/CL-008 Cool TEC1	-5 °C	(Default) +5 °C	+10 °C	+20 °C
G/CL-008 XSWIR 1.9/2.2 TEC2	(Default) -30 °C	-20 °C	-10 °C	0 °C
G/CL-030 TEC1	+5 °C	(Default) +20 °C	+35 °C	+50 °C
G/CL-032 TEC1	+5 °C	(Default) +20 °C	+35 °C	+50 °C
G/CL-032 Cool TEC2	(Default) -20 °C	-5 °C	+10 °C	(N/A)
G/CL-033 TEC1	+5 °C	(Default) +20 °C	+35 °C	+50 °C
G/CL-033 TECless	Not applicable to TECless models.			
G/CL-034 TEC1	+5 °C	(Default) +20 °C	+35 °C	+50 °C
G/CL-034 TEC2	(Default) -30 °C	-20 °C	-10 °C	0 °C
G/CL-034 XSWIR 1.9/2.2 TEC2	(Default) -30 °C	-20 °C	-10 °C	0 °C
G/CL-130 TEC1	+5 °C	(Default) +20 °C	+35 °C	+50 °C

<sup>1</sup> The first temperature setpoint may be set lower than +20 °C. However, if the sensor temperature is lower than the ambient temperature, especially in humid environments, condensation may occur.

Table 249: Defined temperature setpoints for Goldeye cameras

## Achievable temperature difference

The cooling power and heat dissipation capability of the Goldeye is limited. Therefore, the temperature difference ( $\Delta T$ ) achievable by the TEC is limited as well. However, the TEC is capable of achieving a minimum  $\Delta T$  in all situations. [Table 250](#) displays the achievable  $\Delta T$  maintained, and the power consumption necessary to achieve that, for each Goldeye TEC model.

The realistically achievable  $\Delta T$  depends on the environmental conditions. It also depends on the Peltier element and possible heat sinks and heat sources. Heat sources are in particular the camera electronics and the Peltier element itself.

Due to changing environmental conditions, it is not always necessary for the TEC element to maintain the maximum achievable  $\Delta T$ . On the other hand, particular environmental conditions allow the TEC element to achieve an even higher  $\Delta T$ .

Note also that the TEC element cools the sensor but dissipates the removed heat into the camera. Therefore, we can indicate a maximum power at the TEC element that removes the heat from the camera under normal operating conditions.

Above that threshold (at more TEC power) the camera overheats due to the power consumption of the TEC element. The value is optimally selected in a critical range.

Models	$\Delta T$ achievable between housing and FPA	Maximum power to reach $\Delta T$
G/CL-008 TEC1	20 K	< 5.5 W
G/CL-008 Cool TEC1	30 K	< 5.5 W
G/CL-008 XSWIR 1.9/2.2 TEC2	60 K	< 12 W
G/CL-030 TEC1	25 K	< 5.5 W
G/CL-032 TEC1	30 K	< 5.5 W
G/CL-032 Cool TEC2	60 K	< 12 W
G/CL-033 TEC1	25 K	< 4 W
G/CL-034 TEC1	25 K	< 4 W
G/CL-034 TEC2	60 K	< 12 W
G/CL-034 XSWIR 1.9/2.2 TEC2	60 K	< 12 W
G/CL-130 TEC1	25 K	< 5.5 W

Table 250: Cooling limits for Goldeye TEC1 and TEC2 models

## Temperature measurement

To control and regulate the internal camera temperature, three temperature sensors are available within the camera. Use the `DeviceTemperatureSelector` feature to select a temperature sensor, as listed in Table 251. The temperature of the selected sensor is displayed with the `DeviceTemperature` feature.

Possible values	Description
<i>Sensor</i>	(Default) Temperature sensor beside the camera sensor.
<i>Sensorboard</i>	Temperature sensor on the sensor board.
<i>Mainboard</i>	Temperature sensor on the main board.

Table 251: `DeviceTemperatureSelector` values

## Switching temperature setpoints



### Only the sensor board is switched off

- If the internal temperature exceeds the Alert limit, only the sensor and the cooling is shut down.
- The camera is not powered down.
- You may bring back the camera to normal operation after it is cooled down sufficiently.
- To do so, switch the power supply off and switch it on again.

The Goldeye temperature control allows to switch between setpoints manually or automatically. If set to *Auto*, the TEC switches up or down to the next setpoint, based on the temperature inside the camera. Note that the TEC does not switch up or down immediately after the next setpoint is reached. The switch only takes place when the temperature has exceeded the setpoint by a few degrees. TECless models do not switch setpoints.

### Switching to the higher setpoint

After powering up the camera, at first the camera temperature rises. This is due to heat generation inside the camera, and possibly caused by warm ambient temperature. To keep the sensor temperature constant, the TEC keeps it at a predefined temperature setpoint (see [Table 249 on page 317](#)).

The TEC keeps the sensor temperature as long as the difference between sensor temperature and housing temperature does not exceed the predefined  $\Delta T$  (see [Table 250 on page 318](#)).

If the housing temperature keeps rising, the difference between sensor- and housing temperature exceeds the predefined  $\Delta T$ . The temperature control is no longer able to keep the sensor temperature at the current setpoint. The TEC switches up to the next higher setpoint. The existing NUC data, that is optimized for the default setpoint conditions, is still applied at other setpoints.

### Example

The Peltier element of the Goldeye G-033 and CL-033 TEC1 can achieve a  $\Delta T$  of 25 kelvin. Its default temperature setpoint is set to +20 degrees Celsius.

If the camera is switched on at an ambient temperature of +8 degrees Celsius, the TEC cannot cool down the sensor to the default setpoint, because the ambient temperature is below the default setpoint. Therefore, the TEC cools down the sensor to setpoint 1, which is at +5 degrees Celsius. (See [Figure 100](#) for an illustration of this example.)

Note for better understanding: the housing temperature profile is shown in a simplified way that covers the whole temperature range.)

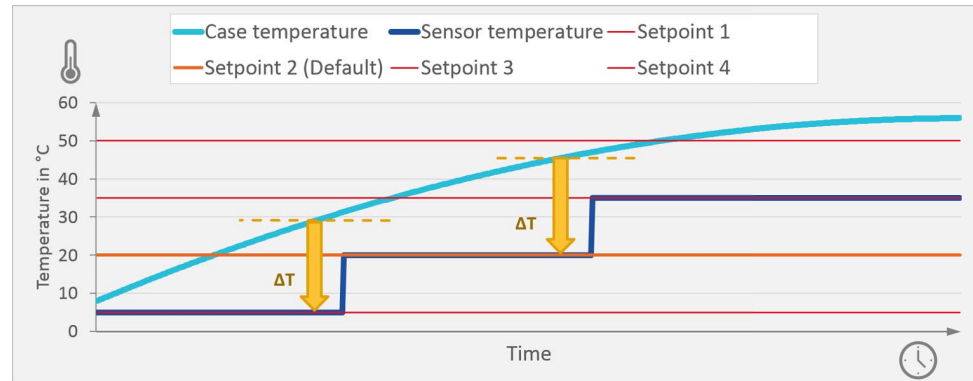

Figure 100: Schematic figure of setpoint switching upwards

The camera then heats up, and the temperature passes setpoint 2. Later it reaches +30 degrees Celsius, the point that is 25 kelvin above the current setpoint. If the camera temperature continues to rise, the TEC is no longer able to maintain the set temperature. No later than at this point in time, the TEC switches to the next higher setpoint, which in this case is the setpoint 2 at +20 degrees Celsius.

## Switching to the lower setpoint

When the ambient temperature decreases, this causes the temperature of the camera to decrease as well. With further temperature decrease, the sensor temperature can fall below the current setpoint temperature. The TEC might be no longer required to cool the sensor to the adjusted temperature setpoint. If the sensor temperature no longer depends on the TEC cooling only, it becomes unstable.

To avoid temperature instability, the TEC switches down to the next setpoint, before the cooling power is reduced to the critical range at the current sensor temperature.

To keep the current sensor temperature as long as possible, the TEC does not switch down immediately when the Min.  $\Delta T$  to the next temperature setpoint is reached. These points are marked in green in [Figure 101](#).



Note for better understanding the housing temperature profile is shown in a simplified way that covers the whole temperature range.

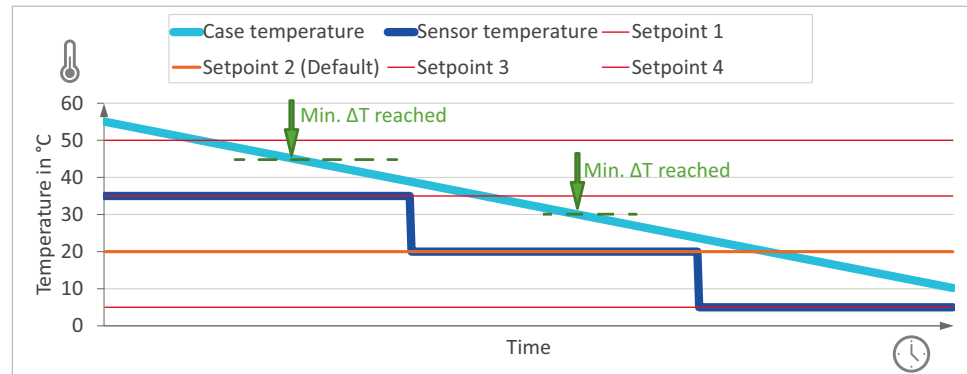

Figure 101: Schematic figure of setpoint switching downwards

## Heating and cooling the sensor (G-008 and CL-008 only)

As a special case, Goldeye G-008 and CL-008 models can actively heat up the sensor, enabling the TEC to operate at a sensor temperature that is higher than the housing or ambient temperature.

When heating is enabled, the TEC does not need to switch down to a temperature setpoint that is below the current setpoint. As long as the housing temperature is below the sensor temperature, the TEC keeps heating the sensor.

If required to keep the sensor temperature stable, the TEC automatically switches from heating to cooling, or vice versa.

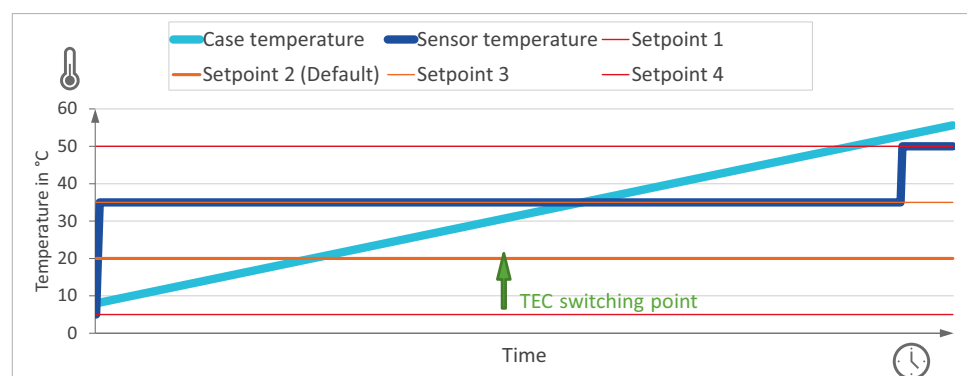

Figure 102: Schematic figure of TEC heating and cooling

During operation, as long as the TEC does not actively cool the sensor, the sensor temperature usually is higher than the housing temperature. So, even if the sensor temperature is below the current temperature setpoint, the TEC might still be required to cool the sensor. The green arrow in Figure 102 shows this situation. Note for better understanding the housing temperature profile is shown in a simplified way that covers the whole temperature range.

The ability to switch to a higher setpoint, however, depends on the feature (Reg)SensorTemperatureSetpointMode:

- Set to *Auto*, the TEC is able to switch to a higher setpoint, if it exists, as shown in [Figure 102](#).
- Set to *Manual*, the TEC is not able to switch to any other setpoint.

## Switching the sensor off

If the internal camera temperature exceeds a preset alert limit, the camera's overheat protection circuit powers down the sensor board. This also includes the sensor cooling.

The Alert state is indicated by a continuous red light of the temperature status LED.

## Temperature setpoint settling time

If the setpoint for sensor temperature is switched, the desired temperature is reached approximately half a minute later. During this period, the image quality may be slightly reduced.

## Goldeye CL-033 TEC1 example

This example explains the functionality of the single-stage TEC1. It is shown in [Figure 103](#).

The Goldeye CL-033 TEC1 has four temperature setpoints:

- +5 degrees Celsius,
- +20 degrees Celsius (default),
- +35 degrees Celsius, and
- +50 degrees Celsius.

It can achieve a maximum temperature difference of 25 kelvin between housing and sensor.

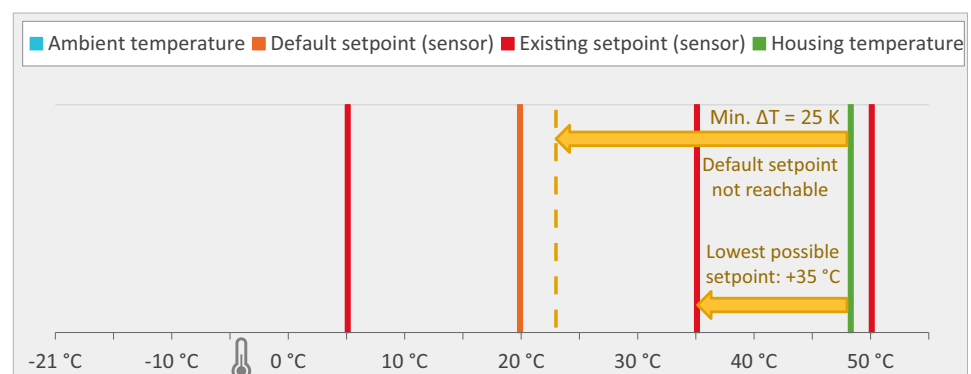

Figure 103: Cooling capabilities of Goldeye TEC1 models (example)

As a result, the CL-033 TEC1 switches to the lowest setpoint it can reach, which is at +35 degrees Celsius, and keeps the sensor at that temperature.

For this example, it is assumed that during operation, the housing temperature of a Goldeye CL-033 TEC1 has leveled at approximately +48 degrees Celsius. Therefore, the minimum sensor temperature the TEC can reach is +23 degrees Celsius. It cannot reach the default setpoint at +20 degrees Celsius.

### Goldeye G-032 Cool TEC2 example

This example explains the functionality of the two-stage TEC2.

The Goldeye G-032 Cool TEC2 has three temperature setpoints:

- -20 degrees Celsius (default),
- -5 degrees Celsius, and
- +10 degrees Celsius.

It can achieve a maximum temperature difference of 60 kelvin between housing and sensor.

For this example, it is assumed that during operation, the housing temperature of a Goldeye G-032 Cool TEC2 has leveled at approximately +38 degrees Celsius.

Because the temperature difference achievable is 60 kelvin, the TEC can reach the default setpoint at -20 degrees Celsius.

Therefore, the G-032 Cool TEC2 will switch to the default setpoint at -20 degrees Celsius and keep the sensor at that temperature.

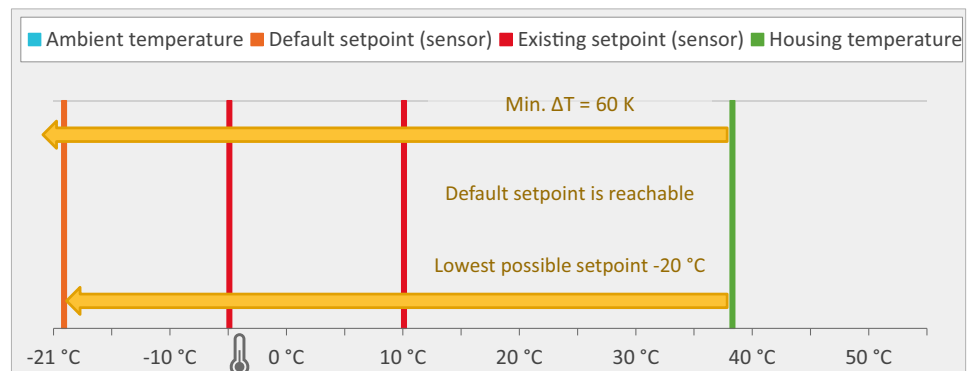

Figure 104: Cooling capabilities of Goldeye TEC2 models (example)

### Goldeye G-008 and CL-008 TEC1 example

This example explains the heat functionality of the single-stage TEC1.

The Goldeye G-008 and CL-008 TEC1 has four temperature setpoints:

- +20 degrees Celsius,
- +25 degrees Celsius (default),
- +35 degrees Celsius, and
- +50 degrees Celsius.

With cooling, it can achieve a maximum temperature difference of 20 kelvin between housing and sensor.

For this example, it is assumed that the camera is started at an ambient temperature of -5 degrees Celsius. The camera is supposed to work at a sensor temperature of +35 degrees Celsius. It is likely that through internal heat-up alone, the camera cannot reach the setpoint at +35 degrees Celsius.

- If the `TemperatureControlTarget` of the camera is **not** activated, the camera levels the sensor temperature at the low setpoint of +20 degrees Celsius.
- If the `TemperatureControlTarget` is activated, the camera heats the sensor and levels the temperature at the setpoint of +35 degrees Celsius.

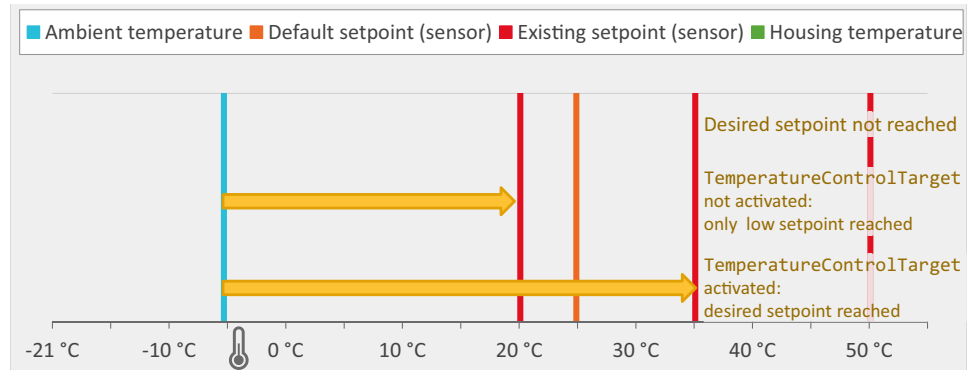

Figure 105: Heating capabilities of Goldeye G/CL-008 models (example)

## Operational statuses

Table 252 explains the operational statuses that are indicated by the temperature status LED on the camera back panel. For TECless cameras, the LED will either remain off, not indicating any TEC status; or it will turn red, indicating overheating.



### Use an efficient heat removal device

If the camera has switched to **Alert** status, it is also recommended to provide a more efficient heat sink for the camera housing before resuming operation. However, additional heat dissipation arrangements are always advantageous.





LED codes	Status and description
	<b>Off</b>
Off	There are two cases when the LED remains off: <ul style="list-style-type: none"> <li>The TEC is actively switched off, using the feature <code>SensorTemperatureControlMode</code>.</li> <li>The camera is a TECless camera that has no TEC available.</li> </ul>
	<b>Deviated</b>
Flashing	The sensor cooler is operating, the defined sensor temperature (setpoint) has not been reached or stabilized yet. This signal is no error signal.
	<b>Stable</b>
Continuous	The temperature is stabilized at one setpoint, the camera operates optimally.
	<b>Upper limit</b>
Flashing	<ul style="list-style-type: none"> <li>The sensor cooler operates at its upper power limit. The cooler is not able to keep the set temperature; however, the critical temperature level has not been reached yet.</li> <li>Under warm ambient temperatures, consider red flashing for an extended period of time as a warning signal: if the camera keeps working under unchanged conditions, an emergency shutdown is likely.</li> <li>The image correction quality may also deteriorate during this stage.</li> </ul>
	<b>Lower limit</b>
Flashing	<ul style="list-style-type: none"> <li>The sensor cooler operates below its lower power limit.</li> <li>Under cold ambient conditions, the cooler may not be required to keep the sensor temperature at the lowest setpoint.</li> <li>The image correction quality may also deteriorate during this stage.</li> </ul>
	<b>Alert</b>
Continuous	<ul style="list-style-type: none"> <li>If the internal camera temperature exceeds the defined threshold temperature, the sensor and the critical electronics of the sensor board conduct an emergency shutdown to prevent overheating. This is called the Alert state. It is indicated by the LED continuously glowing red.</li> <li>In case of Alert, the red color of the LED does not change even if the camera cools down again.</li> <li>The camera can be restarted only manually by switching the power off and on again. This is possible only after the camera cooled down sufficiently.</li> </ul>

Table 252: Temperature status LED

## Features for temperature control

Feature names	Register names
DeviceRelativeHumidity DeviceRelativeHumiditySelector	RegRelativeHumidity[ ] RegRelativeHumidityInq...
DeviceTemperature DeviceTemperatureSelector	RegTemperature[ ] RegTemperatureInq...
SensorCoolingPower	RegSensorCoolingPower
SensorTemperatureControlMode	RegSensorTemperatureControlMode
SensorTemperatureControlState	RegSensorTemperatureControlState
SensorTemperatureSetpointActivate	RegSensorTemperatureSetpointActivate
SensorTemperatureSetpointActive	RegSensorTemperatureSetpointActive
SensorTemperatureSetpointMode	RegSensorTemperatureSetpointMode
SensorTemperatureSetpointSelector	RegSensorTemperatureSetpointSelector
SensorTemperatureSetpointValue	RegSensorTemperatureSetpointValue
SensorTemperatureTargetSetpoint	RegSensorTemperatureTargetSetpoint

*Table 253: Features and register names for temperature management*

Find detailed descriptions of the features controlling the temperature and humidity correction and the functionality associated with them in the Goldeye G/CL Features Reference.

# Firmware update



This chapter explains the firmware update of Goldeye G and CL cameras.

# Updating the firmware

Added features and product improvements motivate new firmware releases.

1. Get the firmware files from Allied Vision Support.



## Firmware files for Goldeye G/CL cameras

The **firmware** for Goldeye G/CL cameras is subject to export limitations. Therefore, it is not available via public download.

To update the firmware of your Goldeye G/CL camera, please contact support at [www.alliedvision.com/en/about-us/contact-us/technical-support-repair-/-rma](http://www.alliedvision.com/en/about-us/contact-us/technical-support-repair-/-rma).

2. Download and install **Vimba SDK**.



## Firmware Updater

**Vimba SDK** includes **Vimba Firmware Updater** and **Vimba Viewer**.

See [www.alliedvision.com/en/support/software-downloads](http://www.alliedvision.com/en/support/software-downloads).

3. Directly connect the camera to your computer.  
**Do not** use a shared connection on a switch with other devices.
4. Open your camera in **Vimba Viewer**.



## NOTICE

### Damage to the camera by destroying the firmware

If the power connection is interrupted while updating the firmware, the camera can come into a dysfunctional state. In this case, the camera cannot be operated and you cannot update the firmware anymore.

- **Ignore the completion message of the Vimba Firmware Updater.**  
We are working to resolve this. We beg your pardon for the inconvenience.
- Keep the camera powered until firmware updates are completed and the camera reboot has been completed. (This can take 10 to 30 minutes.)
- Follow the instructions below.

If the firmware on the camera has been destroyed, please contact the Allied Vision Repair team at [www.alliedvision.com/en/about-us/contact-us/technical-support-repair-/-rma](http://www.alliedvision.com/en/about-us/contact-us/technical-support-repair-/-rma).

5. Using **Vimba Firmware Updater**, upload the new firmware to your camera.  
During the update, the camera is not shown in **Vimba Viewer**.  
The camera LED's are blinking alternately while:
  - The camera writes the new firmware to the permanent storage, replacing the old firmware.
  - The camera is restarted to run the new firmware.
6. **Only after the camera has re-appeared in Vimba Viewer:**  
Start image acquisition to check the update has been successfully completed. Now, the camera can be disconnected from power.



# Cleaning optical components

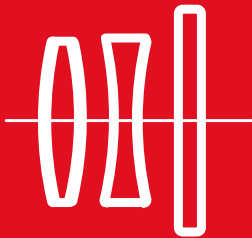

This chapter includes:

Avoiding the necessity of camera cleaning .....	330
Identifying contaminations .....	330
Removing optical filters .....	331
Cleaning instructions .....	332

## Avoiding the necessity of camera cleaning

The best way to keep cameras clean is to avoid penetration of foreign substances into the camera. When (un)mounting lenses or dust caps, hold the camera with the mount opening pointing downwards to avoid contaminants falling on the optical filter or sensor surface. Store cameras and lenses with dust caps on.



*Figure 106: Illustration of camera orientation when removing lens or dust cap*

## Identifying contaminations

Even if contamination particles, such as dust or fluids can be seen on the surface of optical filters or the sensor, the camera image is not necessarily affected because these particles are out of focus.

The contaminations seen in the camera image are situated on the lens, filter, or sensor. Contaminations may develop due to handling or unclean environments.

[Figure 107](#) shows how contaminations on the sensor or on optical components may appear as dark areas, patches, or spots on the image and remain fixed in the preview window while you rotate the camera over the target.

Also, if contaminations are located on the edge of lenses or filters, they may be outside the field of view, and invisible in the image.

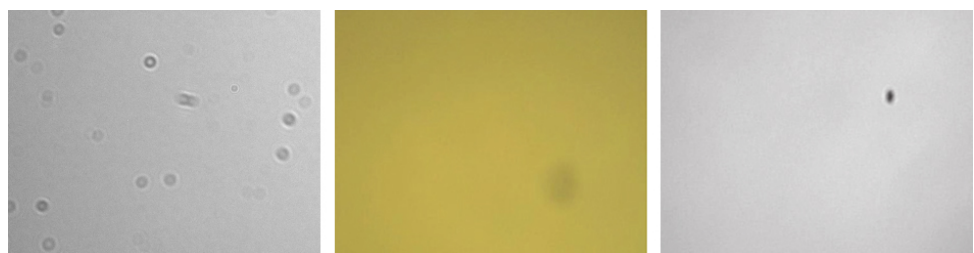

*Figure 107: Dust on the filter (left and middle), dust on the sensor (right)*

Do not confuse a contamination with a pixel defect, which appears as a distinct point. Particles can lie loose or can be stuck to the optical surface.

## Locating contaminations

Before dismounting the lens, determine if the contamination is located on the filter, lens, or sensor. Capture a uniform image with the camera, for example a white sheet of paper. The affected optical surface is identified when optical component in question is moved (rotated) and the dirt follows this movement.

- The **contamination is on the lens** if the contamination moves as well when you rotate only the lens (not the camera).
- The **contamination is on the filter** if the contamination moves when you move the filter window.
- The **contamination is probably on the sensor** if the contamination is on the lens or filter.

## Removing optical filters



### NOTICE

#### Damage to the sensor

The sensor can easily be damaged after the lens, lens cap, and filter have been removed.

- Provide the following conditions to keep dirt and droplets out of the optical system of camera:
  - Dust-free environment
  - Low relative humidity
  - No condensation.
- Use only the tools described in the following instructions.



### NOTICE

#### Damage to the optical filter

Optical filters have a soft surface that can easily be scratched.

- Be very careful when you remove the filter from the camera.
- Follow the instructions in [Using lens mounts and filters](#) on page 210.
- Only use the tools defined in these instructions.
- Touch filters only at the edges, and with cotton gloves.
- Ask your distribution partner for assistance if you have no previous experience.

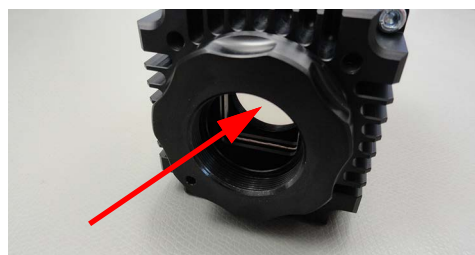

Figure 108: Camera mount without filter, directly exposing the sensor

# Cleaning instructions



## Damage to the sensor and optical surfaces

Improper cleaning materials can damage filter and sensor surfaces.

- Clean the sensor only if you have the experience. Otherwise, send your Goldeye camera to Allied Vision support for cleaning.
- Allowed cleaning method:
  - Use only lens cleaning tissues that are chemically pure and free from silicones or other additives.
  - Wrap lens cleaning tabs or a lens cleaning tissue around a small piece of plastic.
  - Use only isopropyl alcohol as cleaning liquid.
- The following tools are forbidden!!!
  - Do not use dry swabs or tissue because this can cause scratches.
  - Do not use metal tools.
  - Do not use any disposable cotton cosmetic swabs; they may contain contaminants.
  - Do not use cosmetic cotton.
  - Do not use consumer eyeglass cleaning cloths pretreated with silicone.
  - Do not use fibrous material that may get caught in small gaps.
  - Do not use aggressive cleaners like benzine or spirits because this can damage the surface.



## Optical cleaning liquid material safety data sheets

Read the material safety data sheet (MSDS) for the optical cleaning liquid before cleaning your camera and optics. The MSDS provides important information including hazard identification, first aid measures, handling and storage, and PPE.

Carry out all cleaning operations (on lenses, optical filter, and sensor) in a **clean dust-free room**. The optical components are very fragile. Therefore, you must not touch them with your fingers or any hard material.

1. Unplug the camera from any power supply before cleaning.
2. Have the cleaning materials ready before you start the cleaning.

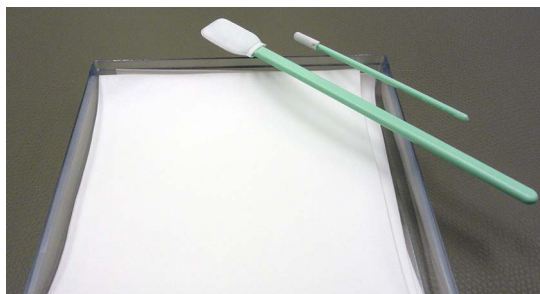

Figure 109: Lens cleaning tissues and cleaning pads

3. Apply a small amount of cleaning liquid to a clean, new lens cleaning pad or tissue.  
The pad or tissue should be moist, not dripping. Hold the camera away from your body to avoid particles like skin flakes from falling onto the sensor. The camera front should point roughly 45 degrees upwards.
4. Wipe the surface in either one of two ways described to ensure any dirt present on the surface be moved to the edge of the surface:
  - With a spiral motion from the center to the rim. Normally, several spiral wipes are recommended. Wipe only on sensor or optical filter avoiding contact to metal surfaces, because microscopic dirt could be released and could cause scratches on the optical filter or sensor.
  - With a straight motion across the optical filter or sensor surface from one end to the opposite end.
5. When you've finished cleaning, examine the surface in a bright light. Take an out-of-focus picture of a flat, illuminated surface to see if any dirt or dust remains.
6. If dust spots remain, repeat this procedure once, using new clean lens tissue (as described).

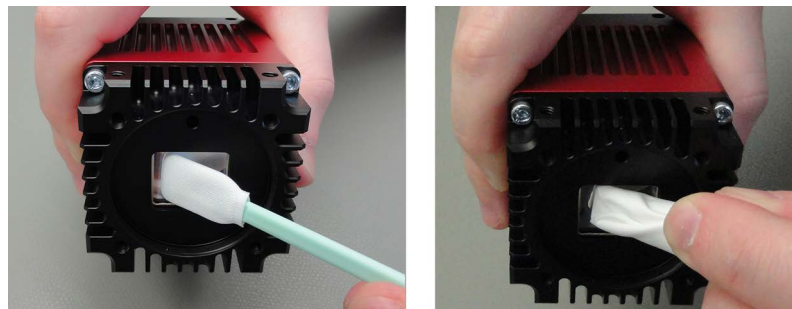

Figure 110: Use of cleaning tab or tissue to clean a sensor



#### **If dust spots remain**

If dust spots remain after cleaning twice, contact your Allied Vision distribution partner.

## Use of compressed air



Figure 111: How not to use compressed air



### NOTICE

#### Damage to the sensor and optical surfaces

Pressed air can move parts out of place or blow dirt and small pieces against optical surfaces.

- Never use compressed air to clean a camera.
- If you want to use compressed air despite of all warnings, consider the following:
  - Use an air blower or compressed air only if you are familiar with cleaning a camera with this instrument.
  - Compressed air may blow dust into cameras and lenses.
  - High pressure air may crack the sensor or optical filter you want to clean.
- Therefore, keep the pressure at a moderate strength only:
  - The pressure at the tube should be less than 1 bar.
  - Operating distance: 5 to 30 cm
  - The pressurized air must be dust-filtered and oil-free.
  - Use ionized air only to avoid any static charge. Moreover, using ionized air helps to remove any dirt stuck to the optical component because of static electricity.

# Index

## A

Absolute QE	
CL-008 Cool TEC1	119
CL-008 TEC1	114
CL-008 XSWIR 1.9 TEC2	125
CL-008 XSWIR 2.2 TEC2	131
CL-032 Cool TEC2	146
CL-032 TEC1	141
CL-033 TEC1	151
CL-033 TECless	156
CL-034 TEC1	161
CL-034 TEC2	166
CL-034 XSWIR 1.9 TEC2	172
CL-034 XSWIR 2.2 TEC2	178
G-008 Cool TEC1	57
G-008 TEC1	53
G-008 XSWIR 1.9 TEC2	62
G-008 XSWIR 2.2 TEC2	67
G-032 Cool TEC2	79
G-032 TEC1	75
G-033 TEC1	83
G-033 TECless	87
G-034 TEC1	91
G-034 TEC2	95
G-034 XSWIR 1.9 TEC2	100
G-034 XSWIR 2.2 TEC2	105
Accessories	
Bandpass filters	229
Camera Link cables	226
Ethernet adapters	226
Heat sink set	230
Hirose 12-pin connector	227
Hirose 4-pin connector	225
Mount adapters	228
Power adapters	224
adjustment	
C-Mount	266
Allied Vision contact	17
Applicable standards	257
Automatic contrast control	306
Automatic exposure control	305
Automatic image control	302
Accounted pixels	302
Eliminating outliers	303
Mean value	302
Outliers	302
Region of interest	304
AutoModeOutliers	303

AutoModeRegion	304
----------------	-----

## B

Background correction	299
Bandpass filter	219
Bandpass filters 1450 nm	222
Binning	301
Block diagram	
Input signal	285
Isolated input	281
Isolated output	283
Signal output	286

## C

Camera cleaning	
Compressed air	334
Identifying contaminations	330
Locating contaminations	331
Necessity	330
Camera Link cables MDR to SDR	226
Camera Link cables SDR to SDR	227
Camera Link interface	272
Camera Link status LEDs	273
Camera software	
Installation	249
Category 6	239
CC1	282
CC2	282
CC3	282
CC4	282
Cleaning instructions	332
C-Mount adapter	
Filter change	261
Specifications	209
Compliance	
USA	39
Control signals	285
Cooling	
Passive cooling	314
Copyright	41
Correction data	298
Cut-off wavelength	220
Cut-on wavelength	220
CWL	220

## D

Decimation	301
Defect pixel correction	299
Delay	
Isolated input	281
Isolated output	284
Dimensions	
Goldeye CL Cool- C-Mount	207

Goldeye CL XSWIR TEC2- C-Mount . . . . .	200	CL-130 TEC1 . . . . .	182
Goldeye G- C-Mount. . . . .	189	G-008 Cool TEC1 . . . . .	56
Goldeye G Cool- C-Mount . . . . .	195	G-008 TEC1 . . . . .	52
Goldeye G Stabilized- C-Mount . . . . .	198	G-008 XSWIR 1.9 TEC2 . . . . .	60
Goldeye G Stabilized- F-Mount . . . . .	190	G-008 XSWIR 2.2 TEC2 . . . . .	65
Goldeye G TEC1- C-Mount . . . . .	187	G-030 TEC1 . . . . .	70
Goldeye G XSWIR TEC2- C-Mount . . . . .	188	G-032 Cool TEC2 . . . . .	78
<b>E</b>		G-032 TEC1 . . . . .	74
electrostatic discharge . . . . .	33	G-033 TEC1 . . . . .	82
Eliminating outliers . . . . .	303	G-033 TECless . . . . .	86
ESD . . . . .	33, 43	G-034 TEC1 . . . . .	90
Ethernet adapters . . . . .	226	G-034 TEC2 . . . . .	94
Exposure . . . . .	293	G-034 XSWIR 1.9 TEC2 . . . . .	98
Exposure control . . . . .	305	G-034 XSWIR 2.2 TEC2 . . . . .	103
External GND . . . . .	279	G-130 TEC1 . . . . .	108
External power. . . . .	279	<b>H</b>	
<b>F</b>		Half Power Points . . . . .	221
Filter change		heat dissipation . . . . .	42
C-Mount adapter . . . . .	261	Hirose 12-pin connector . . . . .	227
F-Mount adapter. . . . .	263	Pin assignment . . . . .	277
M42-Mount adapter. . . . .	264	Hirose 4-pin connector . . . . .	225
Filter tolerance. . . . .	221	Pin assignment . . . . .	278
F-Mount adapter		host computer	
Filter change . . . . .	263	NIC IP address . . . . .	237
Frame grabber		<b>I</b>	
Installation . . . . .	248	I/O connectors . . . . .	276
Use own transport layer. . . . .	257	Image control	
Frame grabber specific viewer . . . . .	252	Frame memory . . . . .	309
Grabbing images . . . . .	255	Trigger-induced distortion correction . . . . .	309
Frame memory . . . . .	309	Image correction	
Frame rates and cooling . . . . .	50	Background correction . . . . .	299
FWHM . . . . .	221	Defect pixel correction . . . . .	299
<b>G</b>		Non-uniformity correction . . . . .	298
General safety notes . . . . .	41	Image corrections . . . . .	298
GigE status LEDs. . . . .	271	Correction data . . . . .	298
GPIOs		Image processing	
CL-008 Cool TEC1 . . . . .	118	Binning. . . . .	301
CL-008 TEC1. . . . .	113	Decimation . . . . .	301
CL-008 XSWIR 1.9 TEC2 . . . . .	123	Look-up table . . . . .	300
CL-008 XSWIR 2.2 TEC2 . . . . .	129	Imaging/Performance specifications	
CL-030 TEC1. . . . .	135	CL-008 Cool TEC1 . . . . .	117
CL-032 Cool TEC2 . . . . .	145	CL-008 TEC1 . . . . .	112
CL-032 TEC1. . . . .	140	CL-008 XSWIR 1.9 TEC2 . . . . .	122
CL-033 TEC1. . . . .	150	CL-008 XSWIR 2.2 TEC2 . . . . .	128
CL-033 TECless . . . . .	155	CL-030 TEC1 . . . . .	134
CL-034 TEC1. . . . .	160	CL-032 Cool TEC2 . . . . .	144
CL-034 TEC2. . . . .	165	CL-032 TEC1 . . . . .	139
CL-034 XSWIR 1.9 TEC21 . . . . .	170	CL-033 TEC1 . . . . .	149
CL-034 XSWIR 2.2 TEC2 . . . . .	176	CL-033 TECless . . . . .	154
		CL-034 TEC1 . . . . .	159



CL-034 TEC2	164
CL-034 XSWIR 1.9 TEC2	169
CL-034 XSWIR 2.2 TEC2	175
CL-130 TEC1	181
G-008 Cool TEC1	55
G-008 TEC1	51
G-008 XSWIR 1.9 TEC2	59
G-008 XSWIR 2.2 TEC2	64
G-030 TEC1	69
G-032 Cool TEC2	77
G-032 TEC1	73
G-033 TEC1	81
G-033 TECless	85
G-034 TEC1	89
G-034 TEC2	93
G-034 XSWIR 1.9 TEC2	97
G-034 XSWIR 2.2 TEC2	102
G-130 TEC1	107
In 1- non-isolated	280
In 2- opto-isolated	281
Install Vimba Viewer	249
Interfaces	
Camera Link	272
IP class	47
Isolated input	
Delay	281
Isolated Out Power	280
<b>L</b>	
lenses	
vignetting	215
Look-up table	300
<b>M</b>	
M42-Mount adapter	
Filter change	264
Manual conventions	
Styles	32
Symbols	32
Mechanics specifications	
CL-008 Cool TEC1	118
CL-008 TEC1	113
CL-008 XSWIR 1.9 TEC2	123
CL-008 XSWIR 2.2 TEC2	129
CL-030 TEC1	135
CL-032 Cool TEC2	145
CL-032 TEC1	140
CL-033 TEC1	150
CL-033 TECless	155
CL-034 TEC1	160
CL-034 TEC2	165
CL-034 XSWIR 1.9 TEC2	170
CL-034 XSWIR 2.2 TEC2	176
CL-130 TEC1	182
G-008 Cool TEC1	56
G-008 TEC1	52
G-008 XSWIR 1.9 TEC2	60
G-008 XSWIR 2.2 TEC2	65
G-030 TEC1	70
G-032 Cool TEC2	78
G-032 TEC1	74
G-033 TEC1	82
G-033 TECless	86
G-034 TEC1	90
G-034 TEC2	94
G-034 XSWIR 1.9 TEC2	98
G-034 XSWIR 2.2 TEC2	103
G-130 TEC1	108
<b>N</b>	
Non-uniformity correction	298
<b>O</b>	
Operating conditions	
CL-008 Cool TEC1	119
CL-008 TEC1	114
CL-008 XSWIR 1.9 TEC2	124
CL-008 XSWIR 2.2 TEC2	130
CL-030 TEC1	136
CL-032 Cool TEC2	146
CL-032 TEC1	141
CL-033 TEC1	151
CL-033 TECless	156
CL-034 TEC1	161
CL-034 TEC2	166
CL-034 XSWIR 1.9 TEC2	171
CL-034 XSWIR 2.2 TEC2	177
CL-130 TEC1	183
G-008 Cool TEC1	57
G-008 TEC1	53
G-008 XSWIR 1.9 TEC2	61
G-008 XSWIR 2.2 TEC2	66
G-030 TEC1	71
G-032 Cool TEC2	79
G-032 TEC1	75
G-033 TEC1	83
G-033 TECless	87
G-034 TEC1	91
G-034 TEC2	95
G-034 XSWIR 1.9 TEC2	99
G-034 XSWIR 2.2 TEC2	104
G-130 TEC1	109
Out 1- non-isolated	282
Out 2- opto-isolated	283

Out 3- opto-isolated	283
Outliers	302
Output specifications	
CL-008 Cool TEC1	118
CL-008 TEC1	113
CL-008 XSWIR 1.9 TEC2	123
CL-008 XSWIR 2.2 TEC2	129
CL-030 TEC1	135
CL-032 Cool TEC2	145
CL-032 TEC1	140
CL-033 TEC1	150
CL-033 TECless	155
CL-034 TEC1	160
CL-034 TEC2	165
CL-034 XSWIR 1.9 TEC2	170
CL-034 XSWIR 2.2 TEC2	176
CL-130 TEC1	182
G-008 Cool TEC1	56
G-008 TEC1	52
G-008 XSWIR 1.9 TEC2	60
G-008 XSWIR 2.2 TEC2	65
G-030 TEC1	70
G-032 Cool TEC2	78
G-032 TEC1	74
G-033 TEC1	82
G-033 TECless	86
G-034 TEC1	90
G-034 TEC2	94
G-034 XSWIR 1.9 TEC2	98
G-034 XSWIR 2.2 TEC2	103
G-130 TEC1	108

## P

Passband	220
Peak Transmittance	221
Pin assignment	276
External GND	279
External power	279
Hirose 12-pin connector	277
Hirose 4-pin connector	278
In 1- non-isolated	280
In 2- opto-isolated	281
Isolated Out Power	280
Out 1- non-isolated	282
Out 2- opto-isolated	283
Out 3- opto-isolated	283
Rx D	279
Tx D	279
Pins 12-pin Hirose	
Pin 1	279
Pin 10	280
Pin 11	281

Pin 12	283
Pin 4	280
Pin 5	283
Pin 6	282
Pin 8	279
Pin 9	279
Pins 4-pin Hirose	279
Power adapters	224
Power Supply	271

## R

Region of interest	304
Relative QE	
CL-030 TEC1	136
CL-130 TEC1	183
G-030 TEC1	71
G-130 TEC1	109
Resolution and ROI frame rates	
CL-008 Cool TEC1	120
CL-008 TEC1	115
CL-008 XSWIR 1.9 TEC2	126
CL-008 XSWIR 2.2 TEC2	132
CL-030 TEC1	137
CL-032 Cool TEC2	147
CL-032 TEC1	142
CL-033 TEC1	152
CL-033 TECless	157
CL-034 TEC1	162
CL-034 TEC2	167
CL-034 XSWIR 1.9 TEC2	173
CL-034 XSWIR 2.2 TEC2	179
CL-130 TEC1	184
G-008 Cool TEC1	58
G-008 TEC1	54
G-008 XSWIR 1.9 TEC2	63
G-008 XSWIR 2.2 TEC2	68
G-030 TEC1	72
G-032 Cool	80
G-032 TEC1	76
G-033 TEC1	84
G-033 TECless	88
G-034 TEC1	92
G-034 TEC2	96
G-034 XSWIR 1.9 TEC2	101
G-034 XSWIR 2.2 TEC2	106
G-130 TEC1	110
RS232	
Rx D	279
Tx D	279
Rx D	279

## S

safety	2, 8
camera power	44
electrical connections	43
heat dissipation	42
lens mounts	42
optical components	44
sensor	45
Sensor	
position accuracy	212
sensor handling	45
Single band filter	222
Specifications	
C-Mount adapter	209
Status LEDs	
Camera Link	273
GigE	271
Temperature	325
Stopband	220
support	17

## T

Temperature	
Control	313
Control features	326
Emergency shutdown	325
Heating of G/CL-008	315
Influence on the sensor	313
Operational statuses	325
stabilization	314
Status LEDs	325
Switching setpoints	319
Trigger	
Latencies and jitter	294
Notes	293
Rules	294
Timing diagram	293
Trigger-induced distortion correction	309
Triggering	
During the Idle state	294
During the Readout state	294
TxD	279

## U

Using custom application	257
--------------------------	-----

## V

Vimba Viewer	
Adjust camera controls	255
Controller window	255
Frame grabber with own transport layer	257

Getting camera information	256
Information window	256
Installation	249
Launch	253
use with frame grabber specific viewer	252

## W

Warm-up period	313
Water filter	222