

Designing in of Alvium Bare Board Cameras

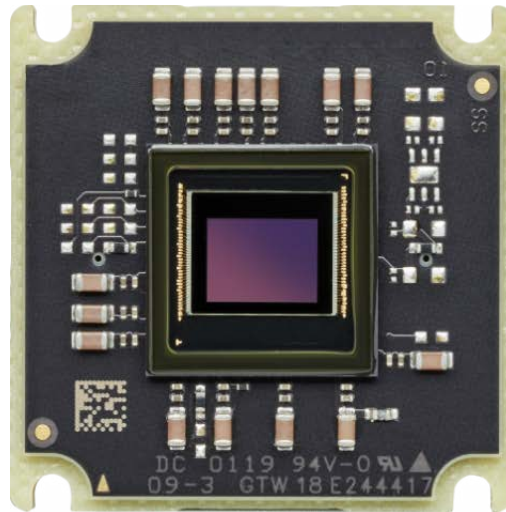

Challenge of integrating bare board cameras

You want to design your own lens mount for Alvium cameras or your application does not need a lens mount? Especially with high resolution sensors, integrating bare board cameras into individual housings can be difficult. This document helps you make a good decision.

Like any solution for digital image processing, bare board cameras consist of numerous different components. Ideally, these components would have constant dimensions and would fit seamlessly to high precision products.

In practice, all parts have tolerances, invisible to the naked eye. For example, typical sensors are allowed to have a tilt of 1 degree according to the specification. Aligning the bare board to the lens is critical. Even micrometer deviations caused by sensor tolerances can reduce the image quality of a high-grade lens on a powerful sensor. Therefore, the bare board must be aligned to position the sensor.

Alvium Frame: Solution out of the box

Alvium Frame adds a square front flange to a bare board camera. It aligns to your individual housing with high accuracy. To give you all the flexibility you need, Alvium Frame is only 10 mm in depth.

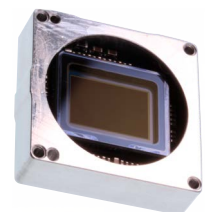

Alvium Modular Concept

For more information on Alvium Frame, see www.alliedvision.com/fileadmin/content/documents/products/cameras/Alvium_common/modular-concept/Alvium-Modular-Concept_External.pdf.

Technical background

Axes for sensor positioning

The following schematics show parameters for sensor positioning. Alvim housings are used as an example.

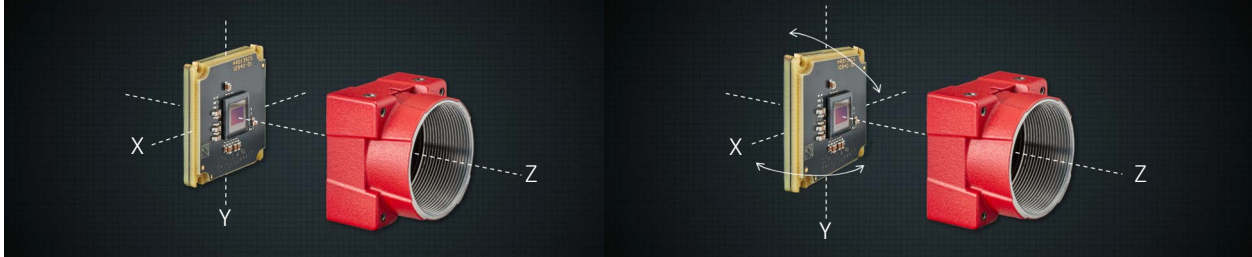

Figure 1: Accurate sensor alignment (left) and sensor tilt on the Z-Axis (right)

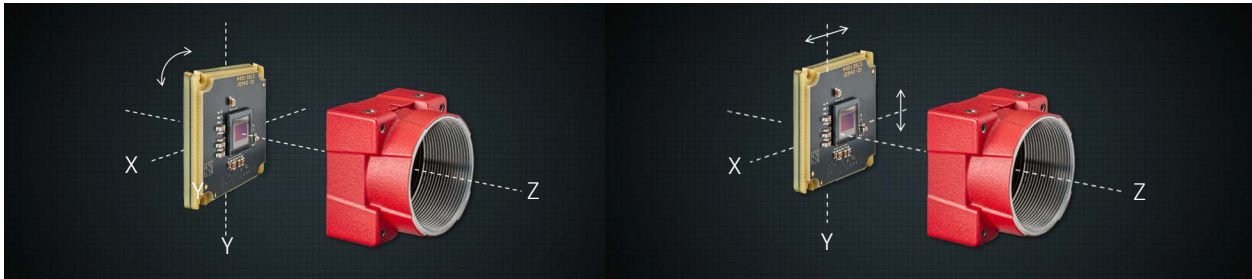

Figure 2: Sensor rotation around the Z-Axis (left) and sensor shift on the X-Axis or Y-Axis (right)

Effects of insufficient sensor alignment

To give you an idea how inaccuracies affect the image quality, we edited an example image without artifacts. The red rectangle in the left bottom corner marks the detail view used to simulate typical effects from insufficient sensor alignment.

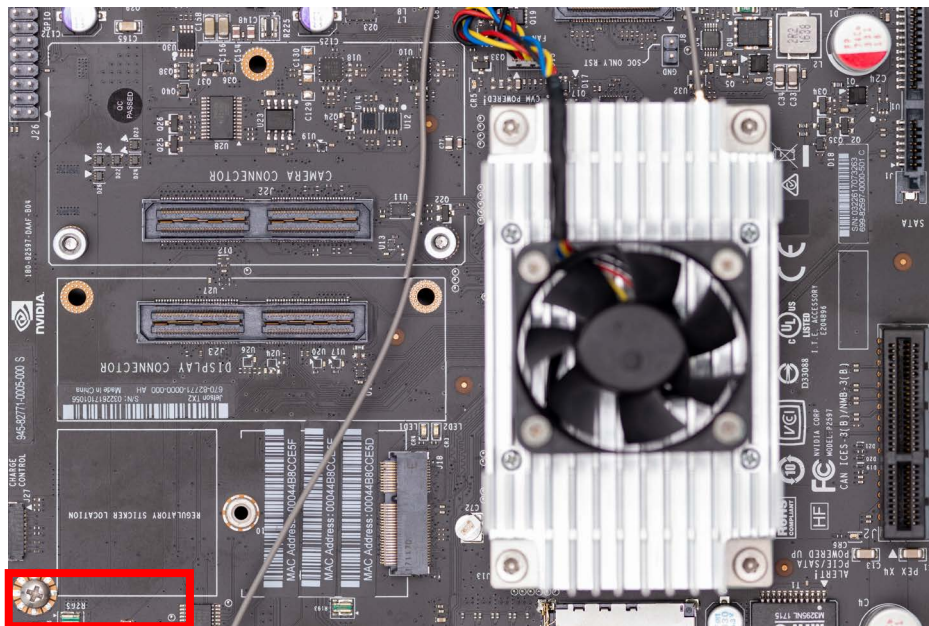

Figure 3: Image without sensor alignment issues

Comparing effects of insufficient sensor alignment

Accurate sensor alignment

The image shows no alignment issues.

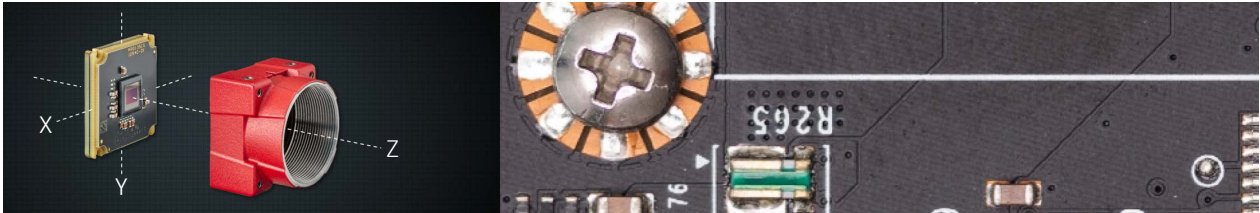

Figure 4: The sensor is accurately aligned to the optical axis of the lens

Tilt on the Z-Axis

The image has a variance of $90\ \mu\text{m}$ between the highest and lowest horizontal pixel of the sensor measured along the optical axis. This equals a rotation of 0.573 degrees around the Y-Axis. The resulting focus drift blurs the vertical edges



Figure 5: The sensor is tilted to the lens mount

Rotation around the Z-Axis

The image is rotated clockwise by 1 degree. The white horizontal line slightly drops to the right.

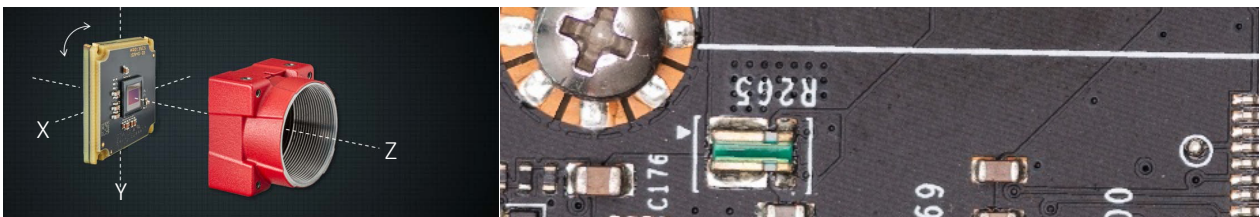

Figure 6: The sensor is twisted to the edge of the PCB (printed circuit board)

Shift along the X-Axis or Y-Axis

The image is shifted to the right by $200\ \mu\text{m}$ (~ 66 pixels). The screw head is cropped on the left.

Note: Depending on the lens, the sharpness can be different between the image corners. Potential vignetting is shifted out of center as well, which is harder to correct than typical vignetting that is centered.



Figure 7: The sensor is shifted along the X-Axis

Tolerances of bare board cameras



Downloads for 3D CAD files

You can download the corresponding 3D CAD file (STEP) for your Alvium bare board camera from www.alliedvision.com/en/support/alvium-step-file-toolbox. Please make sure you select the right camera model!

Figure 8 and Table 1 show the tolerances for the mounting area of Alvium bare board cameras. Adding sensor tolerances, it takes more than a good design to manufacture 100% quality output.

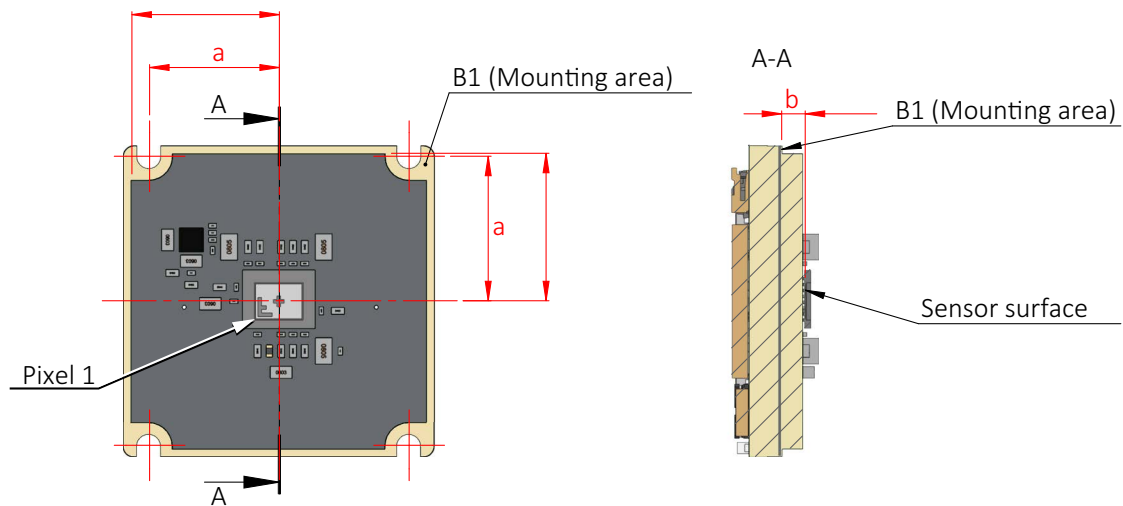

Figure 8: Bare board tolerances

Dimension	Tolerance
a	+/- 500 μm
b	+/-10%

Table 1: Bare board tolerances for draft design

Ask for our service!

We are aware that the tolerances listed above may not meet the accuracy requirements for your design-in. In case you need more accurate values for your mechanical design, we recommend you to consider [Alvium Frame: Solution out of the box](#) on page 1.

Otherwise, please ask us:

- Get most accurate tolerance values for **all axes**.
- Get tolerance values for the **Z-Axis by model**.
- Get tolerance values for **all axes by camera serial number**, from sample measurements out of the production. (This service is charged.)
- Have **your bare board camera integrated** at Allied Vision.

We know the difficulties of sensor alignment from building housed Alvium cameras in series production. Starting from first prototypes, we have reached excellent quality!

Contact us

Website, email

General

www.alliedvision.com/en/contact
info@alliedvision.com

Distribution partners

www.alliedvision.com/en/avt-locations/avt-distributors

Support

www.alliedvision.com/en/support
www.alliedvision.com/en/about-us/contact-us/technical-support-repair-/-rma

Offices

Europe, Middle East, and Africa (Headquarters)

Allied Vision Technologies GmbH
Taschenweg 2a
07646 Stadtroda, Germany
T// +49 36428 677-0 (Reception)
T// +49 36428 677-230 (Sales)
F// +49 36428 677-28

North, Central, and South America, Canada

Allied Vision Technologies Canada Inc.
300 – 4621 Canada Way
Burnaby, BC V5G 4X8, Canada
T// +1 604 875 8855

USA

Allied Vision Technologies, Inc.
102 Pickering Way- Suite 502
Exton, PA 19341, USA
Toll-free// +1-877-USA-1394
T// +1 978 225 2030

Asia-Pacific

China

Allied Vision Technologies Shanghai Co Ltd.
B-510, Venture International Business Park
2679 Hechuan Road
Minhang District, Shanghai 201103
People's Republic of China
T// +86 21 64861133

Japan

Allied Vision Technologies
Yokohama Portside Bldg. 10F
8-1 Sakae-cho, Kanagawa-ku
Yokohama-shi, Kanagawa, 221-0052
T// +81 (0) 45 577 9527

Singapore

Allied Vision Technologies Asia Pte. Ltd
82 Playfair Rd, #07-01 D'Lithium
Singapore 368001
T// +65 6634 9027

Copyright and trademarks

All text, pictures, and graphics are protected by copyright and other laws protecting intellectual property. All content is subject to change without notice. All trademarks, logos, and brands cited in this document are property and/or copyright material of their respective owners. Use of these trademarks, logos, and brands does not imply endorsement. Copyright © 2025 Allied Vision Technologies GmbH. All rights reserved.