



CSI-2 CAMERAS BY FPD-LINK III & GMSL2

Alvium FP3/GM2

User Guide

For information common with Alvium 1500 C or 1800 C, please see the Alvium CSI-2 Cameras User Guide at www.alliedvision.com/en/support/technical-documentation/alvium-csi-2-documentation.

Note: Lenses are not part of this product.

V1.3.0

FW 00.13.00.e83c9689

**Quick links**

- [Alvium FP3/GM2 at a glance](#) on page 15
- [Contact us](#) on page 19
- [Contents](#) on page 20

Read before use

EN - English

Safety

Before using the camera, read these safety instructions. Observe the warnings at all times. Use the camera only as stated in the [Intended use](#) on page 32.

**WARNING**

This product can expose you to chemicals including Carbon Black and Lead Acetate, which is known to the State of California to cause cancer. For more information go to: www.P65Warnings.ca.gov

**CAUTION****Risk of burns**

A camera in operation can reach temperature levels which could cause burns.

**CAUTION****Injury by falling cameras or lenses**

A falling camera or lens can cause injury.

**CAUTION****Risk of cuts by sharp edges of lens mounts**

The threads of the lens mount can have sharp edges.

Intended use

Intended use of Allied Vision product is the integration into vision systems by professionals. All Allied Vision product is sold in a B2B setting.

DA - Dansk

Sikkerhed

Læs sikkerhedsanvisningerne, før kameraet bruges. Overhold alle advarsler. Brug kun kameraet som anført i [Intended use](#) på side 32.



FORSIGTIG

Forbrændingsfare

Når kameraet bruges, kan det blive meget varmt og forårsage forbrændinger.



FORSIGTIG

Kvæstelser, hvis kameraet eller linser falder ned

Falder kameraet eller linsen ned, kan dette forårsage kvæstelser.



FORSIGTIG

Fare for snitsår på linsemodulets skarpe kanter

Linsemodulets gevind kan have skarpe kanter.

Tilsigtet brug

Allied Vision produktets tilsigtede brug er en indbygning i et visionssystem, udført af fagfolk. Alle Allied Vision produkter sælges i B2B.

DE - Deutsch

Sicherheit

Bevor Sie die Kamera benutzen, lesen Sie diese Sicherheitshinweise. Beachten Sie diese Hinweise immer. Verwenden Sie die Kamera nur wie beschrieben in [Intended use](#) auf Seite 32.



VORSICHT

Gefahr von Verbrennungen

Im Betrieb kann die Kamera Temperaturen erreichen, die zu Verbrennungen führen.



VORSICHT

Verletzung durch fallende Kameras oder Objektive

Eine fallende Kamera oder ein fallendes Objektiv kann Verletzungen verursachen.



VORSICHT

Schnitte durch scharfkantige Objektivgewinde

Objektivgewinde können scharfe Kanten haben.

Bestimmungsgemäßer Gebrauch

Allied Vision Produkte sind bestimmt für die Integration in Bildverarbeitungssysteme durch Fachpersonal. Alle Allied Vision Produkte werden in einer B2B-Umgebung verkauft.

ES - Español

Seguridad

Antes de utilizar la cámara lea estas instrucciones de seguridad. Observe las advertencias en todo momento. Utilice la cámara solo tal y como se estipula en el [Intended use](#) en la página 32.



ADVERTENCIA

Este producto puede exponerle a sustancias químicas, como el carbono negro (Carbon Black) y acetato de plomo (Lead Acetate), que el Estado de California considera cancerígenas. Más información disponible en: www.P65Warnings.ca.gov



ATENCIÓN

Riesgo de quemaduras

Una cámara en funcionamiento puede alcanzar temperaturas que podrían provocar quemaduras.



ATENCIÓN

Lesiones en caso de que las cámaras o las lentes se caigan

Si una cámara o una lente se cae puede provocar lesiones.



ATENCIÓN

Riesgo de cortes debido a los bordes afilados del objetivo

Las roscas de los objetivos pueden tener bordes afilados.

Uso previsto

El uso previsto del producto Allied Vision es la integración en el sistema de visión por parte de profesionales. Todos los productos Allied Vision se venden dentro de una relación B2B.

FI - Suomi

Turvallisuus

Lue nämä turvallisuusohjeet ennen kameran käyttöä. Noudata varoituksia joka hetki. Käytä kameraa ainoastaan kohdassa [Intended use](#) sivulla 32 kuvatulla tavalla.



HUOMIO

Palovammojen vaara

Käytössä olevan kameran saavuttamat lämpötilatasot voivat aiheuttaa palovammoja.



HUOMIO

Putoavien kameroiden tai linssien aiheuttamat vammat

Putoava kamera tai linssi voi aiheuttaa vammoja.



HUOMIO

Linssien kiinnikkeiden terävien reunojen aiheuttamien viiltovammojen vaara

Linssin kiinnikkeiden kierteiden reunat voivat olla teräviä.

Käyttötarkoitus

Allied Vision-tuotteen käyttötarkoitus on integrointi kuvajärjestelmiin ammattilaisten toimesta. Kaikki Allied Vision-tuotteet myydään B2B-ympäristössä.

FR - Français

Sécurité

Veillez lire ces consignes de sécurité avant d'utiliser la caméra. Respectez continuellement les avertissements. Utilisez la caméra uniquement comme indiqué sous [Intended use](#), page 32.



ATTENTION

Risque de brûlures

Une caméra en service peut atteindre des niveaux de température susceptibles d'entraîner des brûlures.



ATTENTION

Blessures en cas de chute de caméras ou d'objectifs

La chute d'une caméra ou d'un objectif peut entraîner des blessures.



ATTENTION

Risque de coupures sur les bords tranchants des montures d'objectif

Les filetages des montures d'objectif peuvent présenter des bords tranchants.

Utilisation prévue

L'utilisation prévue du produit Allied Vision est son intégration dans des systèmes de vision par le soin de professionnels. Tout produit Allied Vision est vendu dans un cadre B2B.

עברית - HE

בטיחות

לפני השימוש במצלמה, עליך לקרוא את הוראות הביטחון האלו. עליך לממש הוראות ביטחון אלו תמיד. השימוש במצלמה הוא רק לפי מה שכתוב ב"כוונת השימוש" (Intended use) בעמוד 32.

זהירות

סכנת כווייה

בזמן הפערת המצלמה עלולות טמפרטורות גבוהות לעלות, שיכולות לגרום לכוויות.



זהירות

פגיעה מנפילת מצלמות או עדשות

מצלמה או עדשה שנופלות עלולות לגרום לפגיעה.



זהירות

סכנה להחתך מתברג חד של העדשה

תברג תושבת העדשה עלול להיות חד עד כדי פגיעה.



שימוש מיועד

מוצרי AlliedVision מיועדים לשילוב במערכות ממוחשבת לעיבוד צילומים ע"י אנשי מקצוע. כל מוצרי AlliedVision נמכרים לשימוש בסביבת B2B.

IT - Italiano

Sicurezza

Leggere queste istruzioni per la sicurezza prima di utilizzare la telecamera. Osservare sempre tutte le avvertenze. Utilizzare la telecamera come descritto alla sezione [Intended use](#) a pagina 32.



ATTENZIONE

Pericolo di ustioni

Durante il funzionamento una telecamera può raggiungere temperature elevate che possono essere causa di ustioni.



ATTENZIONE

Lesioni dovute alla caduta di telecamere o lenti

La caduta di una telecamera o di una lente può causare delle lesioni.



ATTENZIONE

Pericolo di tagliarsi sui bordi affilati degli attacchi della lente

I bordi della filettatura dell'attacco della lente possono essere affilati.

Uso previsto

Il prodotto Allied Vision è concepito per essere integrato in sistemi di monitoraggio in campo professionale. Tutti i prodotti Allied Vision sono venduti in uno scenario B2B.

JA - 日本語

安全性

本カメラを使用する前に、この安全の手引きをお読みください。常に、警告事項を守ってください。必ず、[Intended use](#) 32 ページの通りに、本カメラを使用してください。



注意

やけどの危険性

作動中のカメラは、やけどを引き起こす温度まで熱くなる恐れがあります。



注意

カメラまたはレンズの落下によるけが

カメラまたはレンズが落下すると、けがをする恐れがあります。



注意

レンズマウントの鋭利な端部で切り傷の危険性

レンズマウントのギザギザの部分が鋭利である可能性があります。

用途

Allied Vision製品は、専門家が視覚装置に統合することを意図したものです。すべてのAllied Vision製品は、企業間取り引き用に販売されています。

NL - Nederlands

Veiligheid

Lees deze veiligheidsinstructies voordat u de camera gaat gebruiken. Neem deze waarschuwingen altijd in acht. Gebruik de camera uitsluitend, zoals aangegeven in het [Intended use](#) op pagina 32.



VOORZICHTIG

Risico van verbranding

Een camera die gebruikt wordt, kan temperatuurwaarden bereiken die brandwonden kunnen veroorzaken.



VOORZICHTIG

Letsel door vallende camera's of lenzen

Een vallende camera of lens kan letsel veroorzaken.



VOORZICHTIG

Risico van snijwonden door scherpe randen van lensbevestigingen

Het schroefdraad van de lensbevestiging kan scherpe randen hebben.

Beoogd gebruik

Het beoogde gebruik van het Allied Vision-product is de integratie in optische systemen door professionals. Alle Allied Vision-producten worden verkocht in de B2B-markt.

NO - Norsk

Sikkerhet

Les disse sikkerhetsinstruksene før du bruker kameraet. Følg advarslene til en hver tid. Bruk kun kameraet i samsvar med [Intended use](#) på side 32.



FORSIKTIG

Risiko for brannskader

Et kamera i bruk kan nå temperaturnivåer som kan forårsake brannskader.



FORSIKTIG

Skade ved fallende kameraer eller linser

Et fallende kamera eller en fallende linse kan forårsake skade.



FORSIKTIG

Risiko for kutt fra skarpe kanter på linsefester

Sporene på linsefestet kan ha skarpe kanter.

Tiltenkt bruk

Den tiltenkte bruken av Allied Vision-produktet er integrering i visjonssystemer av profesjonelle. Alle Allied Vision-produkter selges i en forretning til forretning-situasjon.

SV - Svenska

Säkerhet

Läs igenom säkerhetsinstruktionerna innan du använder kameran. Var hela tiden särskilt uppmärksam på varningarna. Använd enbart kameran på det sätt som anges i [Intended use](#) på sida 32.



VARNING

Risk för brännskada

En kamera i drift kan komma upp i temperaturer som kan orsaka brännskador.



VARNING

Risk för skador från fallande kameror eller objektiv

Fallande kameror eller objektiv kan förorsaka skador.



VARNING

Risk för skärsår från vassa kanter på objektivfattningar

Objektivets gängor kan ha vassa kanter.

Avsedd användning

Den avsedda användningen av Allied Vision-produkter är integrering i visionssystem av fackmän. Samtliga Allied Vision-produkter säljs i en B2B-miljö.

ZH - 简体中文版

安全需知

使用本相机前，请阅读本安全说明书。请务必遵守相关警告 和 [Intended use](#) 于第 32 页。



注意事项

烫伤风险

相机操作过程中温度可能上升并导致烫伤风险。



注意事项

相机或者镜头跌落造成伤害

相机或者镜头可能会跌落并造成伤害。



注意事项

镜头接口的锐利边缘划伤风险

镜头接口螺纹边缘可能较为锐利。

预期用途

Allied Vision 产品的预期用途是由专业人士整合到视觉系统中。所有 Allied Vision 的产品均通过 B2B 渠道销售。

Alvium FP3/GM2 at a glance



Get an overview of Alvium FP3/GM2 camera documentation:

Notes	16
Consider for Alvium FP3/GM2 cameras	16
Contents in this user guide	17
Shipping contents.....	17
What else do you need?	17

Notes



Read this document carefully

Learn to avoid damage to your Alvium FP3/GM2 camera and use it in the most safe and efficient way.

For information common with Alvium 1500 C / 1800 C, please see the Alvium CSI-2 Cameras User Guide at www.alliedvision.com/en/support/technical-documentation/alvium-csi-2-documentation.



NOTICE

Damage to the camera and connected hardware by improper handling

Setup and operation for Alvium FP3/GM2 cameras in embedded systems is different than for cameras in PC-based systems. Components can easily be damaged.

- If you are unfamiliar with embedded systems, be extremely careful.
- Observe the safety notes and warnings.
- Follow the instructions in [Installing the hardware](#) on page 56.

Consider for Alvium FP3/GM2 cameras

Alvium FP3/GM2 can be used where maximum 420 mm FPC interface cables for standard Alvium CSI-2 are too short. For applications with static cables, Alvium FP3/GM2 cameras are available as **Coax** models, supporting 15 m with FAKRA coaxial cables. For applications with moving cables, we recommend using Alvium FP3/GM2 **STP** models with HSD STP cables, up to 10 m for FP3 and up to 8 m for GM2 models. Improving signal integrity enables greater cable lengths.



Changed hardware to support pixel mode

First series Alvium GM2 cameras and deserializer boards for GMSL2 used the Reference over Reverse (RoR) feature and the tunneling mode. Because typical available carrier boards do not support RoR and use pixel mode, camera and deserializer hardware have been changed. See [Coax models, bootstrapping for GM2](#) on page 73 and [STP models, bootstrapping for GM2](#) on page 74.



You are new on FPD-Link III or GMSL2?

Installing and operating Alvium FP3/GM2 cameras requires deep previous knowledge of the technologies for FPD-Link III and for GMSL2. If you are new on the topic, we recommend you to contact the Allied Vision Support team at www.alliedvision.com/en/about-us/contact-us/technical-support-repair/-rma.



Compatible Vimba version

For full feature range and proper operation, download **Vimba X** from www.alliedvision.com/en/products/software/vimba-x-sdk.

Contents in this user guide

Most data in this document is common for Alvium FP3/GM2 Coax and STP models. Differences between Coax and STP are noted separately.

This user guide contains only data that is different from data for Alvium 1500 C and 1800 C cameras. Read the Alvium CSI-2 Cameras User Guide for information that is common for Alvium FP3/GM2 and Alvium 1500 C / 1800 C cameras.

Shipping contents

- Alvium FP3/GM2 camera
- Download Instructions for First Camera Operation document

What else do you need?

This is a selection of helpful downloads:



	Download	Link
	Alvium CSI-2 Cameras User Guide	www.alliedvision.com/en/support/technical-documentation/alvium-csi-2-documentation
FPD-Link III	Application note SNLA301 on DESER-to-SER setup	www.ti.com
GMSL2	MAX96717 DPHY Evaluation Kit data sheet	www.analog.com/media/en/technical-documentation/data-sheets/max96717-aak-evk-max96717r-ack-evk.pdf
	Alvium CSI-2 Register Controls Reference	www.alliedvision.com/en/support/technical-documentation/alvium-csi-2-documentation
	Alvium Features Reference	www.alliedvision.com/en/support/technical-documentation/alvium-csi-2-documentation
	Application notes	www.alliedvision.com/en/support/technical-documentation/alvium-csi-2-documentation
	Driver for Alvium FP3/GM2 cameras, code examples, and more	www.alliedvision.com/en/products/software/embedded-software-and-drivers
	Vimba X SDK for Linux/ARM, including Vimba X Viewer , Driver Installer , and Firmware Updater	www.alliedvision.com/en/products/software/vimba-x-sdk

Table 1: Downloads for Alvium FP3/GM2 cameras (sheet 1 of 2)

Download	Link
Firmware downloads	www.alliedvision.com/en/support/firmware-downloads
Accessories , such as FAKRA coaxial cables, HSD STP cables, and deserializer boards, power and I/O cables, lenses, and tripod adapters	www.alliedvision.com/en/products/accessories
STEP files	Find downloads for Alvium FP3/GM2 models at www.alliedvision.com/en/support/alvium-step-file-downloads .

Table 1: Downloads for Alvium FP3/GM2 cameras (sheet 2 of 2)

Contact us

Website, email

General

www.alliedvision.com/en/contact
info@alliedvision.com

Distribution partners

www.alliedvision.com/en/avt-locations/avt-distributors

Support

www.alliedvision.com/en/support
www.alliedvision.com/en/about-us/contact-us/technical-support-repair-/-rma

Offices

Europe, Middle East, and Africa (Headquarters)

Allied Vision Technologies GmbH
Taschenweg 2a
07646 Stadtroda, Germany
T// +49 36428 677-0 (Reception)
T// +49 36428 677-230 (Sales)
F// +49 36428 677-28

Asia-Pacific

China

Allied Vision Technologies
(Shanghai) Co., Ltd.
2-2109 Hongwell Int. Plaza
1602# ZhongShanXi Road
Shanghai 200235, China
T// +86 21 64861133

Singapore

Allied Vision Technologies Asia Pte. Ltd
82 Playfair Rd, #07-01 D'Lithium
Singapore 368001
T// +65 6634 9027

North, Central, and South America

Canada

Allied Vision Technologies Canada Inc.
300 – 4621 Canada Way
Burnaby, BC V5G 4X8, Canada
T// +1 604 875 8855

USA

Allied Vision Technologies, Inc.
102 Pickering Way- Suite 502
Exton, PA 19341, USA
Toll-free// +1-877-USA-1394
T// +1 978 225 2030

Contents

Read before use	2
EN - English	2
DA - Dansk	3
DE - Deutsch	4
ES - Español	5
FI - Suomi	6
FR - Français	7
HE - עברית	8
IT - Italiano	9
JA - 日本語	10
NL - Nederlands	11
NO - Norsk	12
SV - Svenska	13
ZH - 简体中文版	14
Alvium FP3/GM2 at a glance	15
Notes	16
Consider for Alvium FP3/GM2 cameras	16
Contents in this user guide	17
Shipping contents	17
What else do you need?	17
Contact us	19
Document history and conventions	24
Document history	25
Conventions used in this user guide	26
Typographic styles	26
Symbols and notes	26
GenICam for CSI-2 Access	27
Terms and acronyms	27
Compliance, safety, and intended use	29
Camera identification	30
Compliance notifications	30
For customers in the US	30
Supplier Declaration of Conformity	31
Party issuing Supplier's Declaration of Conformity	31
Responsible party - US contact information	31
For customers in Canada	31
Pour utilisateurs au Canada	31

Avoid electromagnetic interferences	32
Intended use	32
Copyright and trademarks	32
Your safety	33
Handling lens mounts	33
Camera mounting	34
Heavy lenses	34
Product safety	34
ESD	34
Electrical connections	35
Supported deserializers and embedded boards	35
Strain relief for all cable connections	35
Handling connectors and cables	36
Camera power	37
Ground loops	37
Optical components	37
Sensor	38
Lenses	39
Specifications	40
Applied standards	41
FPD-Link III and GMSL2	41
GenICam	41
MIPI CSI-2	41
V4L2	42
IP class	42
Color codes for interface cable connectors	42
Shock and vibration	42
IEC 60068-2-6: Sinusoidal vibration	43
IEC 60068-2-27: Shock	43
IEC 60068-2-64: Random vibration	43
Available camera models	44
Specs for FP3/GM2 vs. 1500 C / 1800 C	45
Bandwidth and frame rates	46
Conditions for storage and operation	46
Power consumption	46
Dimensions and mass	47
Coax models: Technical drawings	47
Coax models: C-Mount	47
Coax models: CS-Mount	48
Coax models: S-Mount	49
STP models: Technical drawings	50

STP models: C-Mount	50
STP models: CS-Mount	51
STP models: S-Mount	52
Lens mounts and maximum protrusion	53
Lenses: Focal length vs. field of view	54
Access modes	55
Installing the hardware	56
Touching hot cameras.	57
Scope of instructions.	57
Software installation.	57
Hardware installation	57
Mounting the camera	58
Bottom or top mounting	58
Front mounting.	59
Adapting maximum torque values	59
Mounting the lens	60
Mounting and focusing S-Mount lenses.	61
Connecting FAKRA coaxial cables.	64
FAKRA coaxial cable-side connectors	64
Instructions for connecting	65
Instructions for disconnecting.	65
Connecting HSD STP cables	66
HSD STP cable-side connectors	66
Instructions for connecting	67
Instructions for disconnecting.	67
Configuring DESER and SER	68
Power supply	68
Camera interfaces	69
Precautions	70
Back panels for Coax and STP models	71
Coax models: Back panel	71
STP models: Back panel	71
STP connector pin assignment	72
DESER to SER connection overview	72
GM2: Basic information	73
Coax models: Bootstrapping for GM2	73
STP models: Bootstrapping for GM2	74
FP3: DESER setup.	74
General requirements	75
Power supply.	75

Coaxial connections	75
Coaxial cables and connectors – general specifications	75
Coaxial cables and connectors – recommendations	75
Coax: GPIO latency	76
STP connections	77
STP cables and connectors – general specifications	77
STP cables and connectors – recommendations	77
STP: GPIO latency	77
Serializer configuration	79
Coax models: Bootstrapping	79
STP models: Bootstrapping	79
Example register configuration	80
GPIO Configuration Examples	81
Data flow DESER to SER	81
Data flow SER to DESER	81
I/O description	82
I/O connector pin assignment	82
Pin assignment on Alvium FP3/GM2 cameras	83
I/Os and GPIOs	84
Isolated input description	84
Isolated output description	85
Non-isolated GPIOs description	87
Input levels	87
Output levels	88
Status LED	89
Normal operation	89
Error conditions	89
Triggering	90
Firmware update	91
Image data flow	92
Performance	93
Validated systems	94
FP3: Hardware setups	94
GM2: Hardware setups	95
FP3/GM2 Coax: Software setup	95
Bandwidth	95
Index	96

Document history and conventions



This chapter includes:

Document history	25
Conventions used in this user guide.....	26
Terms and acronyms	27

Document history

Version	Date	Remarks
V1.3.0	2024-Mar-05	<p>Release: Firmware version: 00.13.00.e83c9689</p> <ul style="list-style-type: none"> Updated supporting firmware version. For hardware changes to support pixel mode: <ul style="list-style-type: none"> Added note in Consider for Alvium FP3/GM2 cameras on page 16. Updated electronic schematics for Coax models, bootstrapping for GM2 on page 73 and STP models, bootstrapping for GM2 on page 74. In Available camera models on page 44, added support for models coming soon: FP3/GM2-320 VSWIR, -507 Pol, -508 Pol, and -530 VSWIR. Applied editorial changes.
V1.2.0	2023-Sep-27	<p>Firmware version: 00.12.00.00611a22</p> <p>In Available camera models on page 44, added support for:</p> <ul style="list-style-type: none"> FP3/GM2-203 models. FP3/GM2-131, and-192 models (coming soon).
V1.1.1	2023-Aug-10	<p>Firmware version: 00.12.00.00611a22</p> <p>Increased mass by 5 g in Dimensions and mass on page 47 to include thermal compound.</p>
V1.1.0	2023-Aug-09	<p>Firmware version: 00.12.00.00611a22</p> <ul style="list-style-type: none"> Renamed this document from Alvium FP3/GM2 Coax User Guide to Alvium FP3/GM2 User Guide to include Alvium FP3/GM2 STP cameras. Added support for Alvium FP3/GM2 STP cameras. Updated list for Available camera models on page 44. Applied editorial changes.
V1.0.2	2023-Jul-12	<p>Release: Firmware version: 00.12.00.00611a22</p> <ul style="list-style-type: none"> Added safety notes for Proposition 65 by the State of California in Read before use on page 2. Increased maximum housing temperature for operation to 65 °C in Conditions for storage and operation on page 46. Adjusted contents in Firmware update on page 91. Applied editorial changes.

Table 2: Document history (sheet 1 of 2)

Version	Date	Remarks
V1.0.1	2023-Apr-24	<ul style="list-style-type: none"> Completed naming for deserializer Texas Instruments DS90UB953-Q1. Added manufacturer link for Alvium CSI-2 Adapter for Auvideo JNX30 Carrier Board.
V1.0.0	2023-Apr-18	Release: Firmware version: 00.11.00.9cf0c21e Release version

Table 2: Document history (sheet 2 of 2)

Conventions used in this user guide

To give this document an easily understood layout and to emphasize important information, the following typographical styles and symbols are used:

Typographic styles

Style	Function
Emphasis	Programs or important things
Features and registers	Names for GenICam features or for camera control registers
<i>Feature and register options</i>	Options for GenICam features or for camera control registers
<i>Input commands</i>	Text or command to type in by the user, selectable options
UIElements	Text displayed or output by the system: GUI, dialog boxes, buttons, menus, important information, or windows titles
Web addresses and references	Links to webpages and internal cross references

Table 3: Typographic styles

Symbols and notes



CAUTION

Risk of burns

Precautions are described



CAUTION

Injury by falling cameras or lenses

Precautions are described

CAUTION
Risk of cuts by sharp edges of lens mounts

Precautions are described

NOTICE
Material damage

Precautions are described.

Practical tip

Additional information helps to understand or ease handling the camera.

Avoiding malfunctions

Precautions are described.

Additional information

Web address or reference to an external source with more information is shown.

GenICam for CSI-2 Access

Selected Alvium FP3/GM2 models support **GenICam for CSI-2 Access**. Data applying to **GenICam for CSI-2 Access** is marked as follows:



Paragraphs and graphics

A gray box with this icon signals that contents apply to **GenICam for CSI-2 Access** only.

Terms and acronyms

Term or acronym	Description	Reference
DESER	Deserializer	DESER to SER connection overview on page 72
ESD	Electrostatic discharge	ESD on page 34
GND	Ground (power)	I/O connector pin assignment on page 82
SER	Serializer	DESER to SER connection overview on page 72
SerDes	Serializer-deserializer technology	FPD-Link III and GMSL2 on page 41

Table 4: Terms and acronyms (sheet 1 of 2)

Term or acronym	Description	Reference
SFNC	Standard Features Naming Convention (GenICam)	www.emva.org
S-Mount	M12-Mount	Mounting and focusing S-Mount lenses on page 61

Table 4: Terms and acronyms (sheet 2 of 2)

Compliance, safety, and intended use



This chapter includes:

Camera identification.....	30
Compliance notifications	30
Intended use	32
Copyright and trademarks	32
Your safety.....	33
Product safety	34

Camera identification

You can identify your Alvium FP3/GM2 camera like this:



Hardware option	Model ID
Closed housing Alvium FP3 Coax	A 1 J
Closed housing Alvium FP3 STP	A 1 K
Closed housing Alvium GM2 Coax	A 1 O
Closed housing Alvium GM2 STP	A 1 P

Table 5: Hardware options and model IDs

Compliance notifications



National regulations on disposal must be followed.

For customers in the US



Class B digital device

This equipment has been tested and found to comply with the limits for a Class B digital device, pursuant to part 15 of the FCC Rules. These limits are designed to provide reasonable protection against harmful interference in a residential installation. This equipment generates, uses and can radiate radio frequency energy and, if not installed and used in accordance with the instructions, may cause harmful interference to radio communications. However, there is no guarantee that interference will not occur in a particular installation. If this equipment does cause harmful interference to radio or television reception, which can be determined by turning the equipment off and on, the user is encouraged to try to correct the interference by one or more of the following measures:

- Reorient or relocate the receiving antenna.
- Increase the separation between the equipment and receiver.
- Connect the equipment into an outlet on a circuit different from that to which the receiver is connected.
- Consult the dealer or an experienced radio/TV technician for help.

Supplier Declaration of Conformity

Alvium FP3/GM2 cameras comply with Part 15 of the FCC Rules. Operation is subject to the following two conditions:

1. This device may not cause harmful interference, and
2. This device must accept any interference received, including interference that may cause undesired operation.

Party issuing Supplier's Declaration of Conformity

Allied Vision Technologies GmbH
Taschenweg 2a
07646 Stadtroda, Germany
T// +49 (36428) 677-106
quality@alliedvision.com

Responsible party - US contact information

Allied Vision Technologies, Inc.
102 Pickering Way – Suite 502
Exton, PA 19341, USA
T// +1 978 225 2030

Note: changes or modifications not expressly approved by the party responsible for compliance could void the user's authority to operate the equipment.

For customers in Canada

This apparatus complies with the Class B limits for radio noise emissions set out in the Radio Interference Regulations.

CAN ICES-3 (B) / NMB-3 (B)

Pour utilisateurs au Canada

Cet appareil est conforme aux normes classe B pour bruits radioélectriques, spécifiées dans le Règlement sur le brouillage radioélectrique.

CAN ICES-3 (B) / NMB-3 (B)

Avoid electromagnetic interferences

Interface cables, power cables, and I/O cables are sensitive to electromagnetic interference.

- Use shielded cables only.
- We recommend using cables offered by Allied Vision.
- Avoid coiling.
- We recommend using GPIOs only in environments with low electromagnetic interference.

Moreover, avoid unnecessary bending to prevent damage to the cables.

Intended use

Allied Vision's objective is the development, design, production, maintenance, servicing and distribution of digital cameras and components for image processing. We are offering standard products as well as customized solutions.

Intended use of Allied Vision product is the integration into Vision systems by professionals. All Allied Vision product is sold in a B2B setting.

Allied Vision isn't a legal manufacturer of medical product. Instead, Allied Vision cameras and accessories may be used as components for medical product after design-in by the medical device manufacturer and based on a quality assurance agreement (QAA) between Allied Vision (supplier) and medical device manufacturer (customer). Allied Vision's duties in that respect are defined by ISO 13485, clause 7.2 (customer-related processes, equivalent to ISO 9001, clause 8.2).

Copyright and trademarks

All text, pictures, and graphics are protected by copyright and other laws protecting intellectual property. All content is subject to change without notice.

All trademarks, logos, and brands cited in this document are property and/or copyright material of their respective owners. Use of these trademarks, logos, and brands does not imply endorsement.

Copyright © 2024 Allied Vision GmbH. All rights reserved.

Your safety

This section informs about issues related to your personal safety. Descriptions explain how to avoid hazards and operate Alvium FP3/GM2 cameras safely.

Handling lens mounts

The lens mount thread has sharp edges. Be careful these edges do not cut your skin when mounting or unmounting lenses.

Handling hot cameras

Depending on the individual setup, Alvium FP3/GM2 cameras can exceed the specified maximum operating temperature. In many cases, mounting the camera on a metal surface or using a lens will be sufficient to cool the camera effectively. However, especially when operated in higher ambient temperatures, additional measures for heat dissipation, such as using a heat sink, should be considered.

If you have doubts or questions, please feel free to contact your Allied Vision Sales representative for support!

If the mainboard temperature exceeds the specified maximum for more than two seconds, the camera is powered off automatically. The current value for mainboard temperature is output by `DeviceTemperature`. You can use this value to control cooling by software, for example, to control a fan.

However, if you hold the camera in your hands during operation, your skin may get hurt. If you touch the camera when it is heated up, we recommend wearing protective gloves.

Providing optimum heat dissipation

Keep the operating temperature in the specified range to enable best image quality and to protect the camera from damage.

For your safety and to improve image quality, we recommend operating the camera:

- Mounted to a base with a high thermal conductivity
- With lens or other optical components mounted
- With a heat sink mounted that has large surface areas
- Using conductive media for camera and heat sink mounting
- With active cooling of camera, mounting base, and heat sink, such as by ventilation.
- Reduce high ambient temperature. For example, in outdoor applications with direct sunlight, provide shading by an enclosure.

Camera mounting

Cameras must be mounted using the mounting threads. If vibration is higher than specified, cameras can disconnect from the mounting base. Falling cameras can hurt you. To avoid personal injury:

- Mount the camera according to the instructions in [Mounting the camera](#) on page 58.
- Ensure, shock and vibration do not exceed the specified range, see [Shock and vibration](#) on page 42.
- Use a lens support if you want to use [Heavy lenses](#).

Heavy lenses

For non-static applications, use lenses with a mass less than 70 grams and a length less than 38 mm, where the center of gravity is 20 mm, measured from the lens mount front flange. For heavier or longer lenses, use a lens support and apply additional tests. For more information, please contact support at www.alliedvision.com/en/about-us/contact-us/technical-support-repair/-/rma.

Product safety

To prevent material damage, read the following and understand how to safely handle and operate the camera.

ESD

ESD is dangerous for electronic devices, especially when tools or hands get in contact with connectors and electronic components. We recommend measures to avoid damage by ESD:

- **Unpacking:** Remove the camera from its anti-static packaging only when your body is grounded.
- **Workplace:** Use a static-safe workplace with static-dissipative mat and air ionization.
- **Wrist strap:** Wear a static-dissipative wrist strap to ground your body.
- **Clothing:** Wear ESD clothing. Keep components away from your body and clothing. Even if you are wearing a wrist strap, your body is grounded but your clothes are not.

Electrical connections

FPD-Link III and GMSL2 do not specify electrical connections as extensively as the USB or GigE standard. Plug and play is not supported. Read specifications carefully.

Components can easily be damaged. If you are unfamiliar with FPD-Link III, with GMSL2 connections, or with embedded systems, be extremely careful. Follow the instructions in [Installing the hardware](#) on page 56 and see the descriptions in [Camera interfaces](#) on page 69.

Alvium FP3/GM2 cameras are not protected against damage caused by reverse polarity. For specifications, see [I/O connector pin assignment](#) on page 82.

Allied Vision accessories help to avoid damage to the camera and connected components.



Compatible accessories

We recommend using accessories by Allied Vision, see www.alliedvision.com/en/products/accessories.

Supported deserializers and embedded boards

We have tested that Alvium FP3/GM2 cameras can be operated properly with the referenced deserializers and embedded boards. See [Validated systems](#) on page 94. For information on using these components safely, please see the documentation provided by the manufacturers of the corresponding components.

Strain relief for all cable connections

If FAKRA coaxial connectors or HSD STP connectors are exposed to excessive stress, they can break off from devices. Hirose FH55 FPC connectors can be damaged easily.

Provide sufficient strain relief for all cable connections to avoid malfunctions and damage to electronics by wrong polarity and short circuits. To protect cameras and connected components, secure cables as shown in [Figure 1](#).

Alvium FP3/GM2 Coax cameras are designed for **applications with static cables**. For **applications with moving cables**, we recommend using Alvium FP3/GM2 STP cameras.

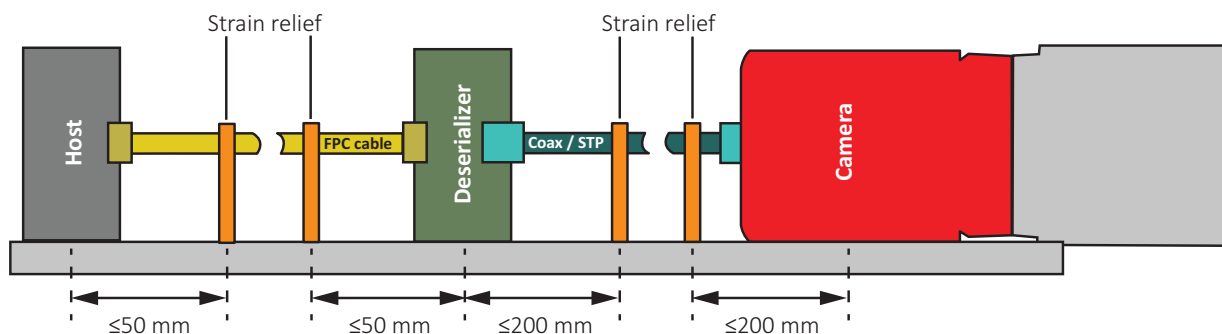

Figure 1: Strain relief for all cable connections

Handling connectors and cables

FAKRA coaxial connectors as well as HDS STP connectors enable a robust connection. However, if the cable is overstressed, these connectors can break off from the camera.

- Unlock the cable connector while you are disconnecting the camera.
- Avoid stress to these connectors and cables.
- Observe the minimum bending radius for these cables.
- Observe instructions for [Strain relief for all cable connections](#) on page 35.
- **Coax:** Follow the instructions in [Connecting FAKRA coaxial cables](#) on page 64.
- **STP:** Follow the instructions in [Connecting HSD STP cables](#) on page 66.



Figure 2: Connectors on cameras (left) and on cables (middle, right)

Pin assignment on STP cables

If Alvium FP3/GM2 STP cameras are operated with incompatible cables, cameras and connected peripherals may be damaged.

- We recommend you to use only STP cables by Allied Vision.
- If you want to use third party STP cables, observe [HSD STP connector pin assignment](#) on page 72 for Alvium FP3/GM2 STP cameras.

No hot-plugging for FPD-Link III or GMSL2

Alvium FP3/GM2 cameras do not support hot-plugging. Hot-plugging can destroy the camera and connected hardware by high inrush current.

Disconnect power supplies before connecting interface cables.

Signal quality

Noise and electromagnetic interference can disable camera functions.

- Avoid squeezing the cable and bending it over edges.
- Avoid contact to metal surfaces, causing electromagnetic interference.
- Please use cables recommended by Allied Vision.



Additional information

For technical data and more instructions on FAKRA coaxial and HSD STP connectors, both Code Z (water blue), see the manufacturer data sheet at www.rosenberger.com.

Camera power

Operating cameras beyond the specified range damages cameras. Cameras are powered using the FAKRA coaxial or the HSD STP connector, using a limited power source (LPS), according to IEC 62368-1. For maximum power input, see [Power consumption](#) on page 46. The camera is not intended to be connected to a DC distribution network.

Only use power supplies that meet the insulation requirement according to PELV or SELV. For details, please refer to IEC 61140.

Use only power supplied by the interface cable

Alvium FP3/GM2 cameras use the same 10-pin TFM connector as Alvium G1 and G5/G5X cameras. But the connector on Alvium FP3/GM2 cameras must not be used as power input.

- Power Alvium FP3/GM2 coax models using the FAKRA coaxial connector, power STP models using the HSD STP connector.
- Use the 10-pin TFM connector only as power output and for I/O control.
- Use the 13870 power supply only for Alvium G1 and G5/G5X cameras.

Ground loops

Unsuitable connections can lead to different potentials between the camera system GND and the environmental shield/chassis GND caused by ground loops. This can damage the camera and the connected devices or cause malfunctions.

- Avoid potential differences between the camera housing and GND.
- All wiring must be done by authorized personnel, according to the corresponding technical standards.
- You may mount the camera electrically isolated.
- Read the Avoiding Ground Loops in Vision Systems application note.



More information

See the Avoiding Ground Loops in Vision Systems application note at www.alliedvision.com/en/support/technical-documentation/alvium-csi-2-documentation.

Optical components

Provide the following conditions to keep dirt and droplets out of the optical system of camera and lens:

- Dust-free environment
- Low relative humidity
- No condensation.

When camera or lens are stored:

- Cover the lens mount with a protection foil or cap.
- Cover front and back lens with caps.

Sensor

Sensors are sensitive to excessive radiation: focused sunlight, UV light, lasers, and X-rays can damage the sensor. Dirt and scratches can damage the sensor as well.

Alvium FP3/GM2 cameras do not need additional cleaning. Cameras are cleaned before shipping. Incorrect cleaning can damage the sensor or the filter. Therefore, never clean the sensor or the filter.

Protect the camera filter and the sensor from dirt, because dirt becomes more visible the closer it gets to the sensor. In addition, keep the back lens clean. Hold the camera with the lens mount facing the ground to keep dirt out of the lens mount. When no lens is mounted, protect the sensor and filter by a dust cap.

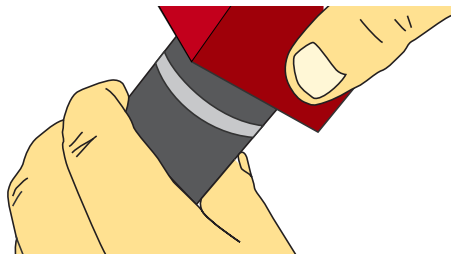

Figure 3: Holding the camera with the lens mount facing the ground

Sensor cleanliness

Alvium cameras are manufactured to match the requirements of typical machine vision applications using f-stops between $f1/4.0$ and $f1/8.0$, equivalent to an opening angle of the incident beam of 14° ($f1/4.0$) to 7° ($f1/8.0$). Of course, f-stop numbers $<f1/4.0$ or angles $>14^\circ$ are included.

Note: The incident beam is not related to the angle of view of the lens.

This enables a clean image for typical monitor view. Particles may become visible when the image is viewed critically, such as with contrast enhancement or edge detection.

This applies to standard Alvium cameras with C-Mount, CS-Mount or S-Mount (also known as M12). Sensors in additional hardware options, such as RCG (Removed Cover Glass) come with a tape attached by the sensor manufacturer.

Lenses

Maximum protrusion

The sensor, filter, lens, or camera electronics can be damaged if a lens exceeding maximum protrusion is mounted to the camera. Use lenses with a maximum protrusion within camera specifications. [Figure 4](#) shows maximum protrusion. For details, see [Lens mounts and maximum protrusion](#) on page 53.

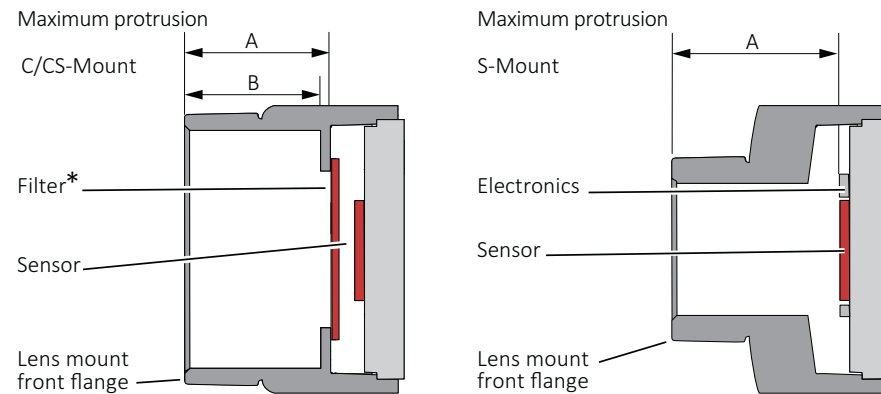

*Only color models are equipped with an IR cut filter

Figure 4: Maximum protrusion C-Mount and CS-Mount (left); S-Mount (right)

For S-Mount lenses, read [Mounting and focusing S-Mount lenses](#) on page 61 to avoid damage to the sensor, electronics, and lens.

Specifications



This chapter includes:

Applied standards	41
Available camera models	44
Specs for FP3/GM2 vs. 1500 C / 1800 C	45
Bandwidth and frame rates	46
Conditions for storage and operation.....	46
Power consumption	46
Dimensions and mass	47
Coax models: Technical drawings	47
STP models: Technical drawings	47
Lens mounts and maximum protrusion	53

For information on

- Alvium 1500 C / 1800 C model specifications
- White balance default
- IR cut filter
- Sensor position accuracy
- User sets
- Camera feature availability

Please see the Alvium CSI-2 Cameras User Guide at

www.alliedvision.com/en/support/technical-documentation/alvium-csi-2-documentation.

Applied standards

FPD-Link III and GMSL2

For both standards, common cables are used to transfer streaming and control data, including power supply by PoC (Power over Coax) or Power over STP.

FPD-Link III is the third version of the Flat Panel Display Link standard. **GMSL2** by **Analog Devices** is the second version of the Multimedia Serial Link standard.

Alvium FP3 and Alvium GM2 cameras use MIPI CSI-2 and I2C as control protocol, encoded and decoded by **SerDes**. Therefore, descriptions for CSI-2 in this document apply to Alvium FP3/GM2 cameras as well.

Coax models support extended cable lengths up to 15 m, **STP** models up to 10 m for FP3 and up to 8 m for GM2 models.



GenICam

GenICam provides a generic access for cameras and devices that is independent of the interface. This enables operating cameras with USB3 Vision, GigE Vision, or CoaXPress interfaces with a common software. With the CSI-2 transport layer for Alvium, MIPI CSI-2 is added.

GenICam consists of multiple modules for different tasks. Allied Vision cameras and software use these modules, like the SFNC that standardizes feature names and types via an XML file or the transport layer interface (GenTL) used to grab images.

Selected Alvium FP3/GM2 cameras comply to:

- GenICam Standard Document Version 2.1.1
- GenAPI Schema Version 1.1
- GenAPI Version 3.1
- GenICam Standard Features Naming Convention (SFNC) Version 2.7
- GenICam Pixel Format Naming Convention (PFNC) Version 2.2

MIPI CSI-2

The MIPI (Mobile Industry Processor Interface) CSI (Camera Serial Interface)-2 standard describes a class of MIPI CSI-2 cameras for still image photography and video streaming. As a benefit, the workload on the host and latencies are reduced significantly compared to USB or GigE.

Generically, Alvium FP3/GM2 cameras are operated by **Direct Register Access**. Alvium FP3/GM2 cameras are based on the MIPI CSI-2 interface. They comply with MIPI CSI-2 V1.1.

V4L2

The current V4L2 framework is described at linuxtv.org. Allied Vision provides V4L2 drivers. You can download Allied Vision V4L2 drivers from www.alliedvision.com/en/products/software/embedded-software-and-drivers.

IP class

Equipped with a lens as intended, Alvium FP3/GM2 cameras comply with IP30 class according to IEC 60529.

Color codes for interface cable connectors

Alvium FP3/GM2 Coax cameras are equipped with FAKRA coaxial connectors, STP models with HSD STP connectors, both Code Z (water blue). Connectors for the automotive industries provide 21 shapes that are color coded, assigned to different applications. Code Z (water blue) has a neutral shape to match all 21.

Shock and vibration

Alvium FP3/GM2 cameras were tested successfully according to the following standards:

- IEC 60068-2-6, sinusoidal vibration testing
- IEC 60068-2-27, shock testing
- IEC 60068-2-64, random vibration testing.

Cameras were inspected before and after the tests. All tests were passed successfully:

Condition	Passed
Mechanics	<ul style="list-style-type: none"> • The camera housings showed no deformations. • The connections between camera components had not come loose. • The sensor position was within the specified tolerances of a new camera.
Camera behavior	Camera functionalities were not affected, no deviations occurred.
Image streaming	Images were streamed without errors.

Table 6: Conditions for passed tests

The conditions for cameras and lenses were the same for all tests. Solid aluminum tubes were used to represent real lenses:

Parameter	Value
Lens dummy length	22 mm
Lens dummy mass	70 g
Center of gravity (CoG) ¹	17 mm

¹For camera and lens dummy assemblies, measured from the lens mount front flange

Table 7: Conditions for lenses

IEC 60068-2-6: Sinusoidal vibration

Frequency	Acceleration	Displacement
10 Hz to 58.1 Hz	Not applicable	1.5 mm
58.1 Hz to 500 Hz	20 g	Not applicable

Table 8: Frequency, acceleration, and displacement for IEC 60068-2-6 tests

Parameter	Value
Axis ¹	x, y, z
Sweep rate	1 oct/min
Sweep duration per axis [hh:mm:ss]	03:45:40
Number of sweeps	10

¹For technical reasons, all three axes are tested with the shaker in the upright position without a sliding table.

Table 9: Other parameters for IEC 60068-2-6 tests

IEC 60068-2-27: Shock

Parameter	Value
Axis	x, y, z
Acceleration	20 g
Number of shocks per axis	10
Duration per axis	11 ms
Waveform	Half sine

Table 10: Parameters for IEC 60068-2-27 tests

IEC 60068-2-64: Random vibration

Frequency	Acceleration
15 Hz to 500 Hz	0.05 g ² /Hz

Table 11: Frequency and acceleration for IEC 60068-2-64 tests

Parameter	Value
Axis	x, y, z
Acceleration RMS (Sigma)	4.9 g
Acceleration peak (Sigma)	14.8 g
Duration per axis [hh:mm:ss]	00:30:00

Table 12: Other parameters for IEC 60068-2-64 tests

Available camera models

Currently, the following Alvium FP3/GM2 models with FAKRA coaxial and HSD STP connectors are available:

Alvium FP3/GM2	Alvium CSI-2	Sensor
FP3/GM2-030 VSWIR	1800 C-030 VSWIR	Sony IMX991
FP3/GM2-040	1800 C-040	Sony IMX287
On request ²	1500 C-050	OnSemi PYTHON 480
FP3/GM2-052	1800 C-052	Sony IMX426
On request	1500 C-120	OnSemi AR135
FP3/GM2-130 VSWIR	1800 C-130 VSWIR	Sony IMX990
FP3/GM2-158	1800 C-158	Sony IMX273
FP3/GM2-203	1800 C-203	Sony IMX422
FP3/GM2-210	1500 C-210	OnSemi AR0521
FP3/GM2-234	1800 C-234	Sony IMX249
FP3/GM2-235	1800 C-235	Sony IMX174
FP3/GM2-240	1800 C-240	Sony IMX392
FP3/GM2-291	1800 C-291	Sony IMX421
FP3/GM2-319	1800 C-319	Sony IMX265
FP3/GM2-320 VSWIR ¹	1800 C-320 VSWIR ¹	Sony IMX993
FP3/GM2-500	1800 C-500	OnSemi AR0521
FP3/GM2-501 NIR	1500 C-501 NIR	OnSemi AR0522
FP3/GM2-507	1800 C-507	Sony IMX264
FP3/GM2-507 Pol ¹	1800 C-507 ¹	Mono: Sony IMX264MZR Color: Sony IMX264MYR
FP3/GM2-508	1800 C-508	Sony IMX250
FP3/GM2-508 Pol ¹	1800 C-508 ¹	Mono: Sony IMX250MZR Color: Sony IMX250MYR
FP3/GM2-510	1800 C-510	Sony IMX548
FP3/GM2-511	1800 C-511	Sony IMX547
FP3/GM2-530 VSWIR ¹	1800 C-530 VSWIR ¹	Sony IMX992
FP3/GM2-811	1800 C-811	Sony IMX546
FP3/GM2-812 UV	1800 C-812 UV	Sony IMX487
FP3/GM2-895	1800 C-895	Sony IMX267
FP3/GM2-1236	1800 C-1236	Sony IMX304
FP3/GM2-1240	1800 C-1240	Sony IMX226
FP3/GM2-1242	1800 C-1242	Sony IMX545
¹ Coming soon		
² With frozen firmware V00.11.00.9cf0c21e		

Table 13: Available camera models (sheet 1 of 2)

FP3/GM2-1620	1800 C-1620	Sony IMX542
FP3/GM2-2040	1800 C-2040	Sony IMX541
FP3/GM2-2050	1800 C-2050	Sony IMX183
FP3/GM2-2460	1800 C-2460	Sony IMX540

Table 13: Available camera models (sheet 2 of 2)

Specs for FP3/GM2 vs. 1500 C / 1800 C

Because Alvium FP3/GM2 cameras share most specifications with Alvium 1500 C and Alvium 1800 C cameras, this user guide contains only differences. [Table 14](#) gives an overview where to find Alvium FP3/GM2 specifications:

Chapter section	Alvium CSI-2 Cameras User Guide	Alvium FP3/GM2 User Guide
Model specification tables	(✓) All values, except for...	<ul style="list-style-type: none"> Bandwidth Maximum frame rates Power consumption
White balance default	✓	—
Dimensions and mass	—	✓
Technical drawings	—	✓
Lens Mounts and maximum protrusion ¹	✓	✓
IR cut filter	✓	—
Sensor position accuracy	✓	—
User sets	✓	—
Camera feature availability	✓	—

¹Contents are shown in this user guide to avoid damage to the sensor.

Table 14: Availability for camera specifications in Alvium user guides



Specifications shared with Alvium 1500 C / 1800 C

See the Alvium CSI-2 Cameras User Guide at www.alliedvision.com/en/support/technical-documentation/alvium-csi-2-documentation for specifications shared with Alvium FP3/GM2 cameras.

Bandwidth and frame rates

Because of the additional data for packing information, Alvium FP3/GM2 cameras have a reduced bandwidth for image transfer compared to 1500 C and 1800 C. Therefore, Alvium FP3/GM2 models with a high resolution do not reach the maximum frame rates available with Alvium 1500 C or 1800 C models.

On optimized systems, similar frame rates can be reached as with 1500 C and 1800 C models when you are using 2 lanes. When 4 lanes are used, these values typically increase slightly for cameras that reach maximum frame rates with 4 lanes on 1500 C and 1800 C cameras. We cannot predict the available bandwidth for your individual imaging system, because it depends on the setup, including such as hardware components and register settings.

Conditions for storage and operation

Feature	Specification
Storage temperature	-20 °C to +85 °C (ambient)
Operating temperature	-20 °C to +65 °C (housing), +5 °C to +85 °C ¹ (mainboard ²)
Relative humidity	0% to 80% (non-condensing)
¹ +5 °C to +88 °C for 1236, 1240, and 2050 models, +5 °C to +85 °C for other models ² Output by DeviceTemperature	

Table 15: Conditions for storage and operation

Power consumption

Alvium FP3/GM2 cameras use the same power as the corresponding 1500C or 1800 C models, but **adding the power consumption for the serializer** on board the camera. Values for power consumption mainly depend on the sensor model, image resolution, and frame rate.

Feature	Serializer power consumption ¹	Total power consumption ¹
Alvium FP3	0.3 W to 0.6 W	2.0 W to 4.4 W
Alvium GM2	0.8 W to 0.9 W	2.5 W to 4.7 W
¹ Sensor model dependent		

Table 16: Power consumption

Dimensions and mass

Values are common for Alvium FP3 and Alvium GM2 cameras.

Feature	C-Mount	CS-Mount	S-Mount
Flange focal distance, optical [mm]	17.526	12.526	12.63
Thread	1"-32tpi UNS-2B	1"-32tpi UNS-2B	M12 × 0.5
Maximum protrusion ¹ [mm]	13.6	8.6	11.0
Body dimensions (L × W × H [mm])	41 × 29 × 29	36 × 29 × 29	36 × 29 × 29
Mass	70 g	70 g	70 g

¹For details, see [Lens mounts and maximum protrusion](#).

Table 17: Housing dimensions and mass

Coax models: Technical drawings

Technical drawings are common for Alvium FP3/GM2 Coax cameras.

Coax models: C-Mount

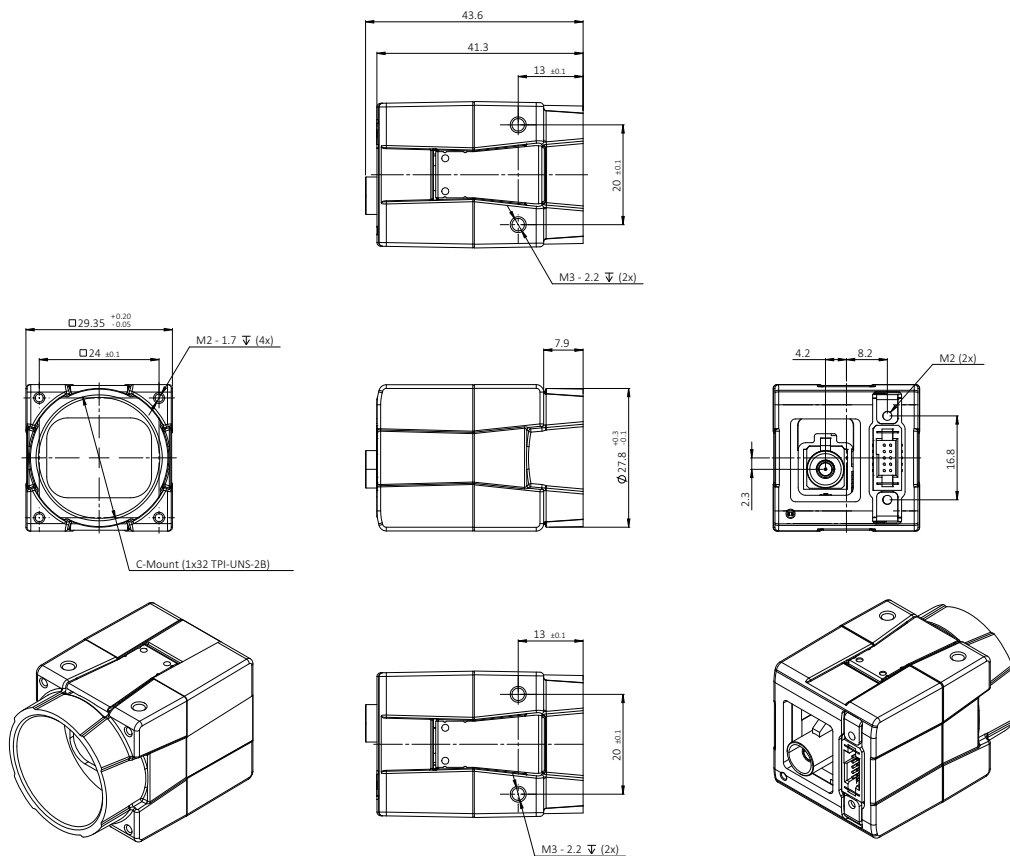

Figure 5: Coax models, C-Mount dimensions

Coax models: CS-Mount

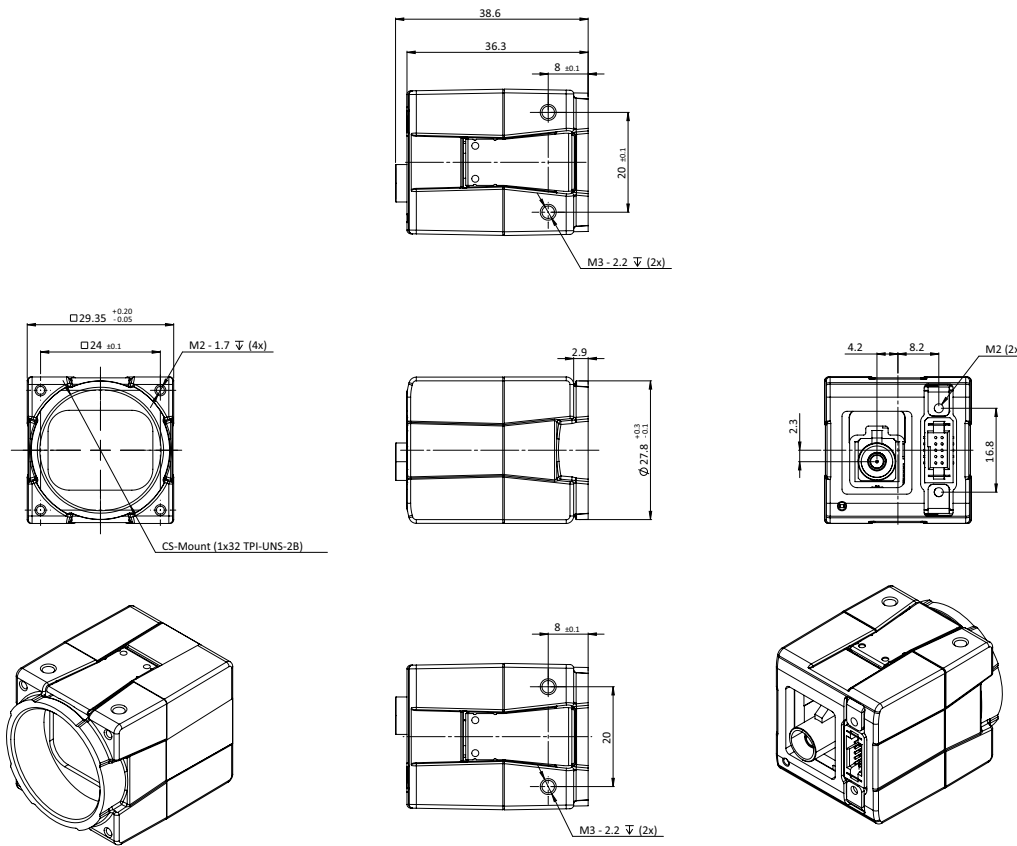

Figure 6: Coax models, CS-Mount dimensions

Coax models: S-Mount

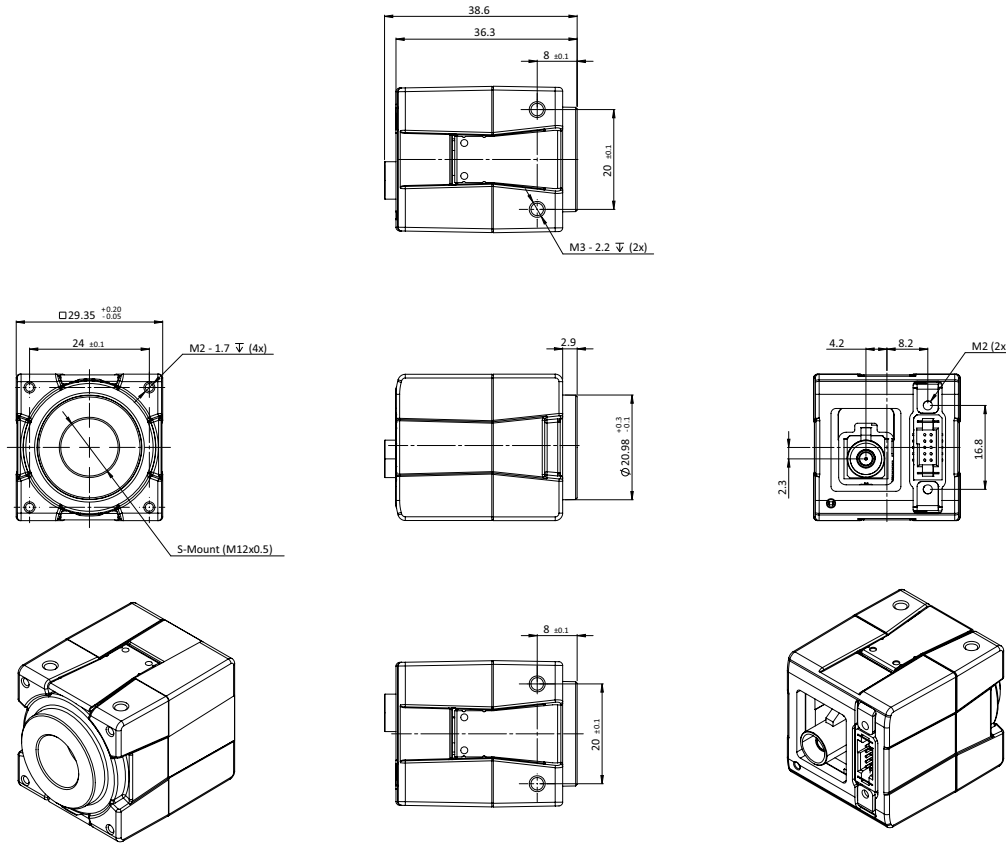

Figure 7: Coax models, S-Mount dimensions

STP models: Technical drawings

Technical drawings are common for Alvium FP3/GM2 STP cameras.

STP models: C-Mount

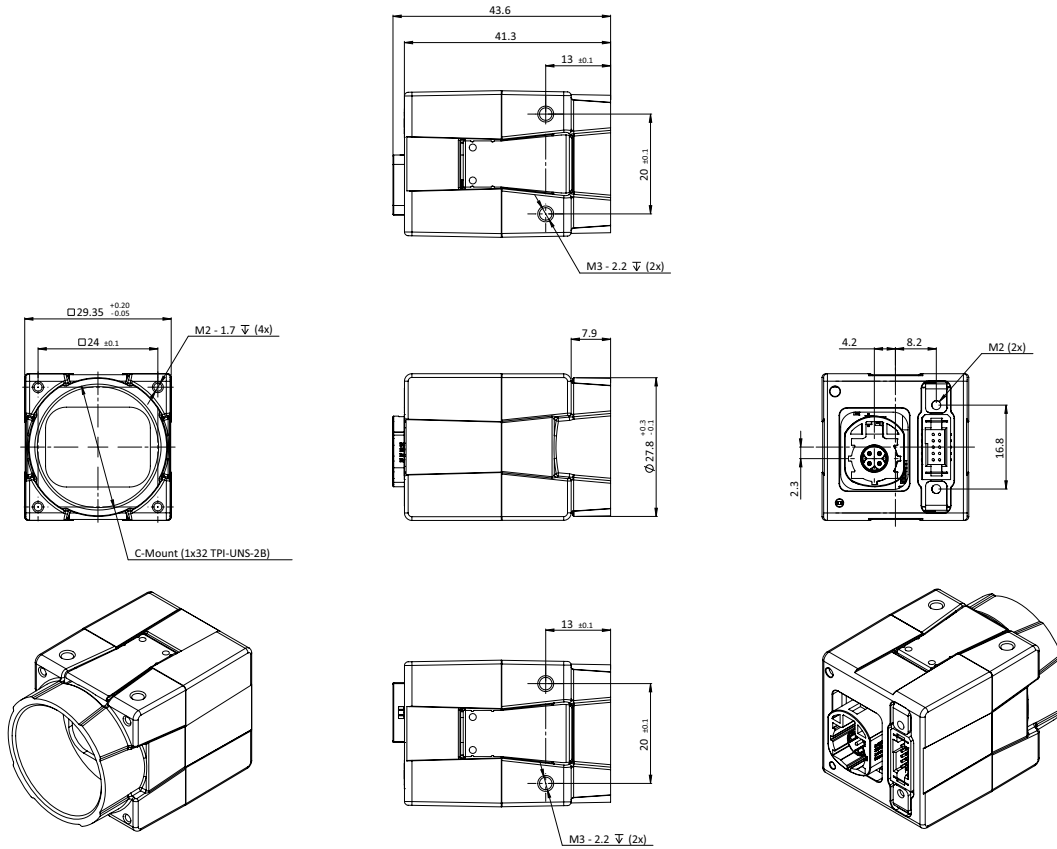

Figure 8: STP models, C-Mount dimensions

STP models: CS-Mount

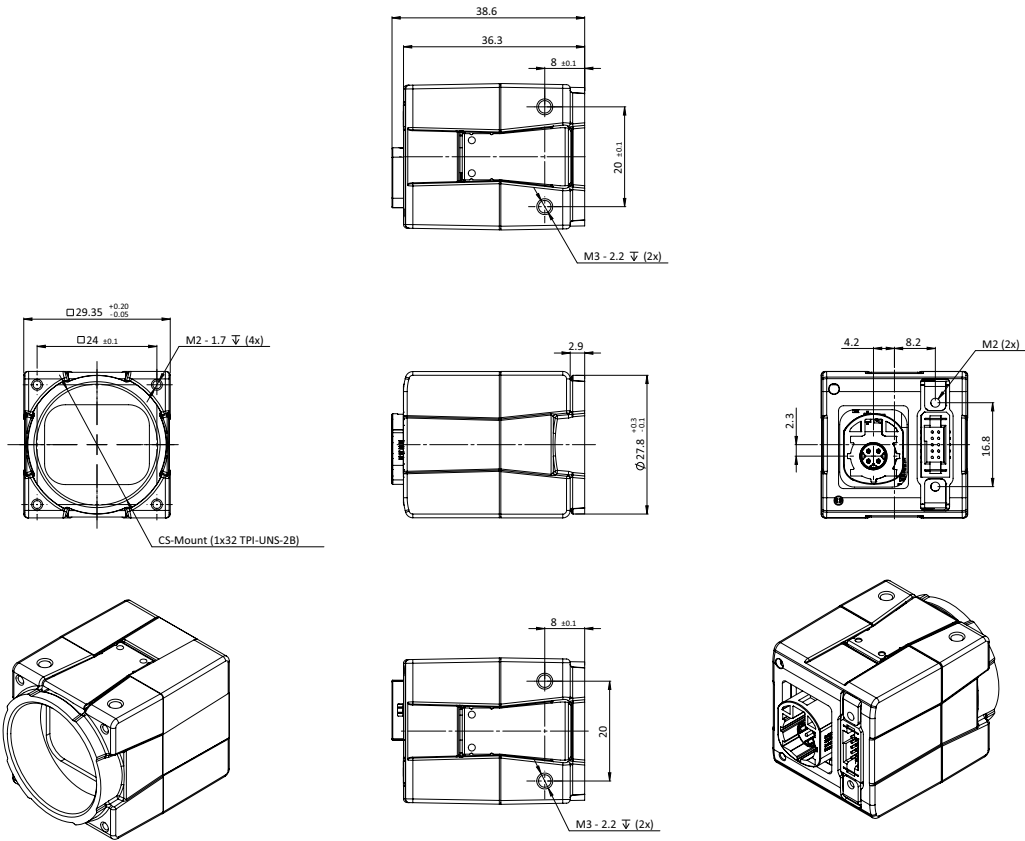

Figure 9: STP models, CS-Mount dimensions

STP models: S-Mount

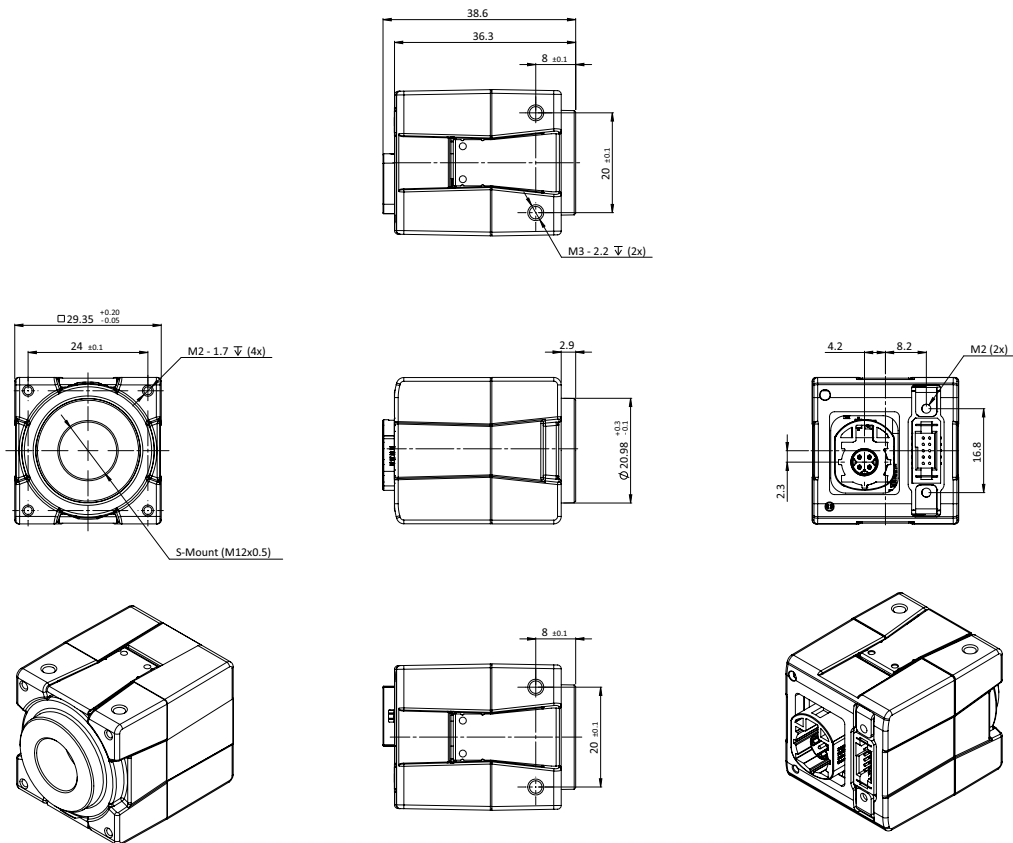

Figure 10: STP models, S-Mount dimensions

Lens mounts and maximum protrusion



No need to readjust lens mounts

Alvium FP3/GM2 camera mounts are adjusted with high precision during manufacturing. Construction ensures permanent accuracy without need to readjust.

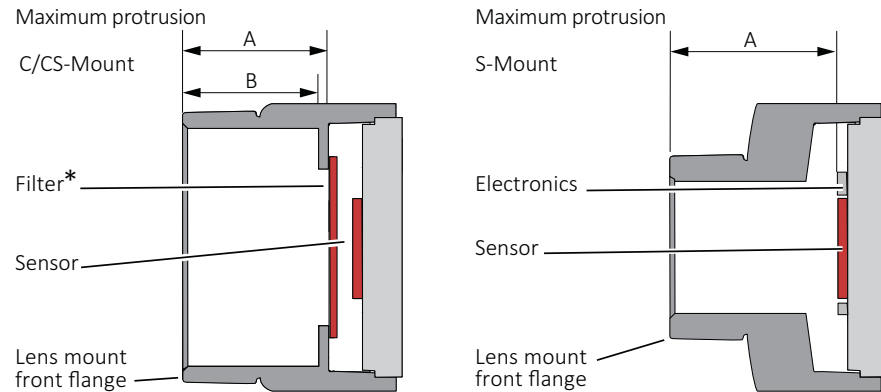

*Only color models are equipped with an IR cut filter

Figure 11: Maximum protrusion C-Mount and CS-Mount (left); S-Mount (right)

Figure 11 shows schematics for maximum protrusion of lenses, Table 18 shows values for maximum protrusion.



NOTICE

Damage to sensor, optics, or electronics by unsuitable lenses

The sensor, filter, lens, or electronics can be damaged if a lens exceeding maximum protrusion is mounted to the camera.

- Use lenses with less than the allowed maximum protrusion, see Table 18.
- See [Mounting the lens](#) on page 60.
- For S-Mount lenses, see [Mounting and focusing S-Mount lenses](#) on page 61.

Mount	Maximum protrusion
C-Mount	13.6 mm
CS-Mount	8.6 mm
S-Mount	11.0 mm

Table 18: Alvium FP3/GM2 cameras maximum protrusion

Lenses: Focal length vs. field of view



For information on

- Optical vignetting
- S-Mount lenses
- Tables for focal length vs. field of view

Please see the Alvium CSI-2 Cameras User Guide at

www.alliedvision.com/en/support/technical-documentation/alvium-csi-2-documentation.

Access modes



For information on

- Direct Register Access
- Video4Linux Access
- GenICam for CSI-2 Access

Please see the Alvium CSI-2 Cameras User Guide at

www.alliedvision.com/en/support/technical-documentation/alvium-csi-2-documentation.

Installing the hardware



This chapter includes:

Touching hot cameras	57
Scope of instructions	57
Mounting the camera	58
Mounting the lens.....	60
Connecting FAKRA coaxial cables.....	64
Connecting HSD STP cables	66
Configuring DESER and SER	68
Power supply	68

Touching hot cameras



CAUTION

Risk of burns

A camera in operation can reach temperature levels which could cause burns.

- Wear protective gloves when you touch a camera that is heated up.
- Ensure proper cooling of the camera.

Scope of instructions



Software installation

Software downloads and documentation

This chapter describes hardware installation only. For information on supported Linux distributions and embedded boards, drivers, libraries, and programming examples, see www.alliedvision.com/en/products/software/embedded-software-and-drivers.

Hardware installation

This chapter instructs on using Alvim FP3/GM2 cameras safely and effectively. However, we cannot provide complete information. The MIPI CSI-2 standard does not specify electrical connections as extensively as USB or GigE standard. Therefore, instructions on camera connections can be general only.

Mounting the camera



CAUTION

Injury by falling cameras or lenses

A falling camera or lens can cause injury.

- Ensure proper mounting of cameras and lenses, especially for dynamic applications.
- Mount cameras as described in the instructions.
- Always make sure the mounting threads are intact.
- Fasten screws with maximum torque, using the entire thread engagement. For less thread engagement, see [Adapting maximum torque values](#) on page 59.
- We recommend you to apply thread locking.
- Use a lens support for heavy lenses.

Bottom or top mounting

Especially for dynamic applications with high acceleration, mount the camera using the bottom mounting threads in addition.

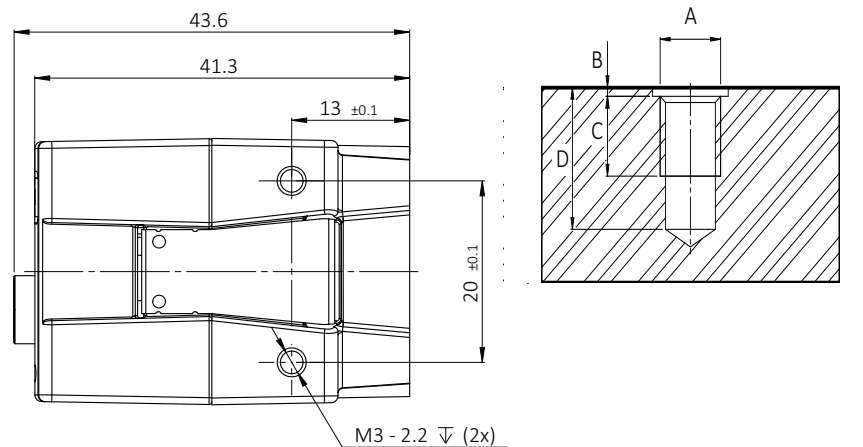

Figure 12: Mounting threads bottom and top (a)

The maximum torque value applies only if the entire thread engagement is used. For other values, see [Adapting maximum torque values](#) on page 59. For technical drawings, see [G1 Closed Housing: Dimensions and mass](#) on page 153.

1. As shown in [Figure 12](#), mount the camera to the base using suitable M3 screws for mounting thread a: At 0.51 Nm maximum torque for a thread engagement (C) of 2.2 mm between screws and mounting threads.
2. Continue with [Mounting the lens](#) on page 60.

Front mounting

Especially for dynamic applications with high acceleration, mount the camera using the bottom mounting threads in addition.

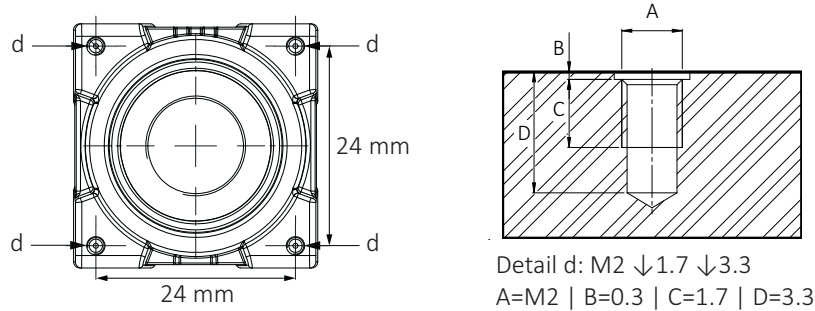

Figure 13: Camera front with mounting threads (c)

The maximum torque value applies only if the entire thread engagement is used. For other values, see [Adapting maximum torque values](#) on page 59.

1. Mount the camera to the base using suitable M2 screws at 0.17 Nm maximum torque for a thread engagement (C) of 1.7 mm between screws and mounting threads, see [Figure 13](#). For technical drawings, see [G1 Closed Housing: Dimensions and mass](#) on page 153.
We recommend you to additionally use bottom and top mounting threads for a more solid connection.
2. Continue with [Mounting the lens](#) on page 60.

Adapting maximum torque values

The total bolt length composes of the mounting holes length and the height of your mounting base.

For using less than the stated length of thread engagement, calculate maximum torque as follows:

$$\frac{\text{Current length of thread engagement}}{\text{Length of thread engagement in table}} \times \text{Torque in table} = \text{Current torque}$$

Example for a length of thread engagement of **1.4 mm** instead of 1.7 mm:

$$\mathbf{1.4\ mm} / 1.7\ \text{mm} \times 0.17\ \text{Nm} = \mathbf{0.14\ Nm}$$

Thread group	Thread position	Thread type	Total protrusion	Length of thread engagement	Maximum torque
b	Front mounting	M2	2 mm	1.7 mm	0.17 Nm
b	Front mounting	M2	2 mm	1.4 mm	0.14 Nm

Table 19: Adjusting maximum torque values

To ensure that the bolts do not become loose over time, we recommend you to use means for securing bolts, such as screw locking varnish

**Tripod adapter**

See www.alliedvision.com/en/products/accessories.

Mounting the lens

Observe the following notes before you mount lenses to Alvium FP3/GM2 cameras.

**CAUTION****Injury by falling cameras or lenses**

A falling camera or lens can cause injury.

- Ensure proper mounting of cameras and lenses, especially for dynamic applications.
- Mount cameras as described in the instructions.
- Use a lens support for heavy lenses.

**CAUTION****Risk of cuts by sharp edges of lens mounts**

The threads of the lens mount can have sharp edges.

Be careful when mounting or unmounting lenses.

**NOTICE****Damage to sensor, optics, or electronics by unsuitable lenses**

The sensor, filter, lens, or electronics can be damaged if a lens exceeding maximum protrusion is mounted to the camera.

- Use lenses only up to the specified maximum protrusion, see [Lens mounts and maximum protrusion](#) on page 53.
- S-Mount lenses must be screwed into the camera at less than maximum protrusion (11.0 mm), see [Mounting and focusing S-Mount lenses](#) on page 61.
- Avoid short S-Mount lenses falling into the camera.

Mounting and focusing S-Mount lenses



Allied Vision S-Mount lenses

For technical data of Allied Vision S-Mount lenses with dedicated operating instructions, see the S-Mount Lenses User Guide at www.alliedvision.com/fileadmin/content/documents/products/accessories/lenses/Allied_Vision/User_Guide/S-Mount-Lenses_User-Guide.pdf.

This section instructs how to use S-Mount lenses with your camera safely.

S-Mount lenses are screwed into the mount to adjust focus. Vibration moves lenses out of position. Several techniques can be used to fasten S-Mount lenses in focus. We recommend using fixing nuts. See instructions in this section.



Drawings and fixing nuts

Drawings in the instructions are schematic.

Several manufacturers offer various types of S-Mount fixing nuts. The type shown in the instructions drawings is an example.

We recommend using pinch nose pliers to tighten fixing nuts.

Figure 14 shows how fixing nuts lock S-Mount lenses. Follow the instructions to lock the lens in focus position.

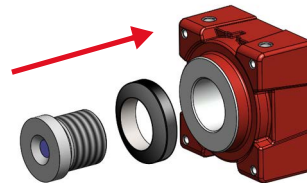

Figure 14: Fixing nut locking an S-Mount lens

NOTICE
Damage to sensor, optics, or electronics by improper handling

If an S-Mount lens is screwed against the sensor or electronics, sensor, lens, or electronics can be damaged.

- Screw in the lens at less than 11.0 mm maximum protrusion.
- Follow the instructions carefully.

Determining the allowed range for the position of the lens

1. Measure the length of the lens.
2. Calculate: $a = c - b$
 a: length of the mounted lens, measured from lens mount front flange
 b: maximum protrusion (11.0mm)
 c: length of the lens

See [Lens mounts and maximum protrusion](#) on page 53.

3. Set a gauge to the length of (a).

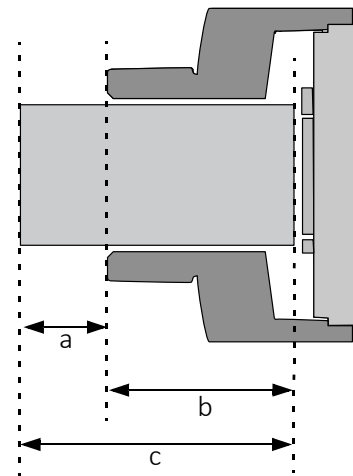

Figure 15: S-Mount lens and protrusion

Mounting the fixing nut to the lens

4. Screw the fixing nut clockwise onto the lens until you can hold the front part (d) of the lens with your finger tips.



Figure 16: Lens and fixing nut

Focusing the lens

5. **Checking (a) with a gauge**, slowly screw the lens clockwise into the lens mount until the image is roughly in focus.
6. Slowly screw in and unscrew the lens until you have found the most accurate focus.

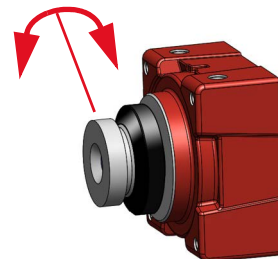

Figure 17: Adjusting focus

NOTICE
Damage to lens threads and fixing nut by excessive force

If the fixing nut is screwed with too much force, threads are worn out and the lens cannot be locked anymore.

Screw fixing nuts hand tight to keep the lens in a fixed position.

Locking focus

Pinch nose pliers are used to screw the fixing nut:

7. Holding the lens in position with one hand, screw the fixing nut clockwise against the lens mount until you feel the lens is locked.

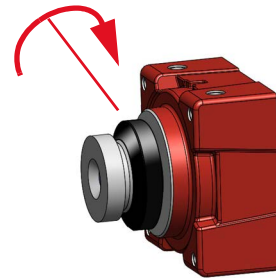

Figure 18: Tightening the fixing nut

Checking focus is set and locked properly

8. Check No.1: Try to rotate the lens with little force in both directions to ensure the lens is safely locked in position.

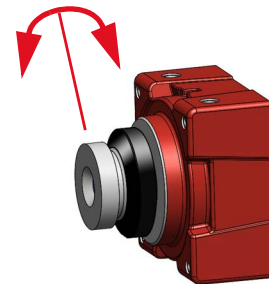

Figure 19: Checking lens is safely locked

9. Check No. 2: S-Mount thread allows a slightly tilted lens position. In this case, focus for a common object plane varies over the image plane.

If focus is constant over the image plane, you are done.

If focus varies over the image plane, the lens is tilted. Continue with [10](#).

10. Loosen the fixing nut.

11. Continue with [6](#).

The lens is locked in focus and ready for operation.

Connecting FAKRA coaxial cables

The robust FAKRA coaxial connectors are optimized for one-time plugging in the automotive industry. Unplugging cable connectors is uncomfortable, which may lead to camera damage. Please follow the instructions in this section.



NOTICE

Damage to the camera

If the FAKRA coaxial connector on the camera is exposed to excessive stress, it can break off from the camera.

- Secure cables as shown in [Strain relief for all cable connections](#) on page 35.
- Follow the instructions below for FAKRA coaxial cables.

FAKRA coaxial cable-side connectors

Figure 20 shows the latch of the locking mechanism of the FAKRA coaxial cable-side connectors in unlocked position (schematics):

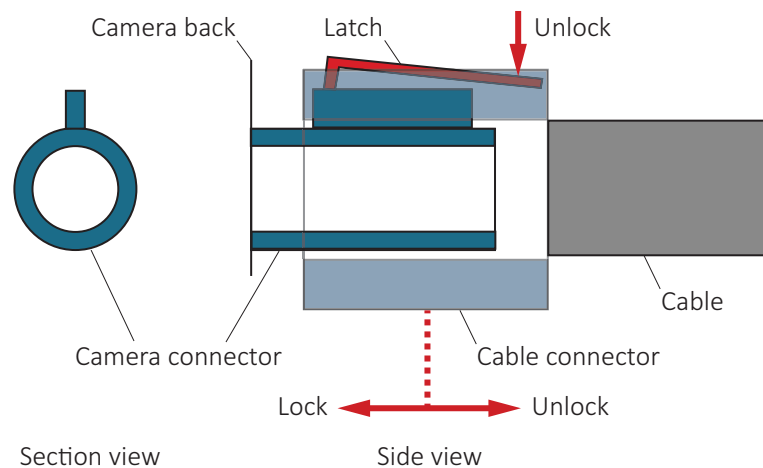

Figure 20: FAKRA coaxial cable-side connector: Locking mechanism

The cable-side connector has a locking mechanism that must be engaged for safe connection. To unplug the cable-side connector, the lever must be **pressed all the time while** the cable is pulled of the camera connector. Otherwise, the camera-side connector can be torn off the camera.

Instructions for connecting

1. Grab the camera with one hand and the cable-side connector with the other hand.
2. Align the groove (b) of the cable-side connector with the notch (a) of the camera-side connector.

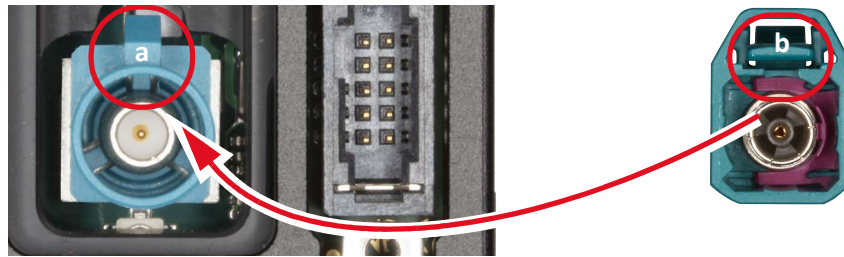

Figure 21: FAKRA coaxial connectors on cameras (left) and on cables (right)

3. Push the cable-side connector over the camera-side connector until it clicks. The camera is connected properly.

Instructions for disconnecting

1. Grab the camera with one hand and the cable-side connector with the other hand.
2. With your fingernail, press down the latch (c) of the cable-side connector.



NOTICE

Damage to the camera

If the camera's FAKRA coaxial connector is exposed to excessive stress, it can break off from the camera.

Keep the latch (c) pressed down until the cable has been completely disconnected from the camera.

3. **Keeping the latch (c) pressed down**, pull the cable-side connector off the camera. You may slightly rotate and tilt the cable-side connector against the camera housing to reduce friction.

The camera is disconnected.



Figure 22: Pressing down the latch (c) of the FAKRA coaxial connector

Connecting HSD STP cables

The robust HSD STP connectors are optimized for one-time plugging in the automotive industry. Unplugging cable connectors is uncomfortable, which may lead to camera damage. Please follow the instructions in this section.



NOTICE

Damage to the camera and connected peripherals

If Alvium FP3/GM2 STP cameras are operated with incompatible cables, cameras and connected peripherals can be damaged.

- We recommend you to use only STP cables by Allied Vision.
- If you want to use third party STP cables, observe [Table 26: HSD STP connector pin assignment](#) on page 72 for Alvium FP3/GM2 STP cameras.



NOTICE

Damage to the camera

If the HSD STP connector on the camera is exposed to excessive stress, it can break off from the camera.

- Secure cables as shown in [Strain relief for all cable connections](#) on page 35.
- Follow the instructions below for HSD STP cables.

HSD STP cable-side connectors

[Figure 20](#) shows the latch of the locking mechanism of the HSD STP cable-side connectors in unlocked position (schematics):

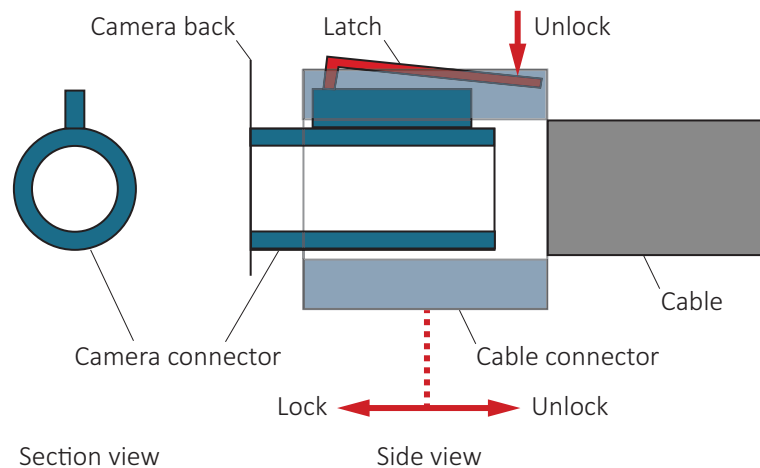

Figure 23: HSD STP cable-side connector: Locking mechanism

The cable-side connector has a locking mechanism that must be engaged for safe connection. To unplug the cable-side connector, the lever must be **pressed all the time while** the cable is pulled of the camera connector. Otherwise, the camera-side connector can be torn off the camera.

Instructions for connecting

1. Grab the camera with one hand and the cable-side connector with the other hand.
2. Align the groove (b) of the cable-side connector with the notch (a) of the camera-side connector.

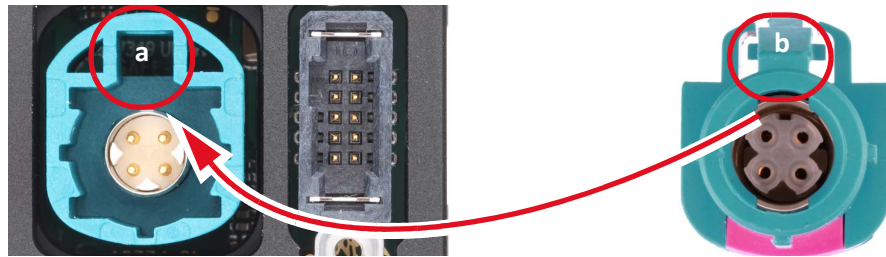

Figure 24: HSD STP connectors on cameras (left) and on cables (right)

3. Push the cable-side connector over the camera-side connector until it clicks. The camera is connected properly.

Instructions for disconnecting

1. Grab the camera with one hand and the cable-side connector with the other hand.
2. With your fingernail, press down the latch (c) of the cable-side connector.



NOTICE

Damage to the camera

If the camera's HSD STP connector is exposed to excessive stress, it can break off from the camera.

Keep the latch (c) pressed down until the cable has been completely disconnected from the camera.

3. **Keeping the latch (c) pressed down**, pull the cable-side connector off the camera. You may slightly rotate and tilt the cable-side connector against the camera housing to reduce friction.

The camera is disconnected.



Figure 25: Pressing down the latch (c) of the HSD STP connector

Configuring DESER and SER

We cannot give you a step-by-step instruction how to configure DESER (deserializer) and SER (serializer) for your vision application. We recommend you to use the **SerDes Configurator** to set up your vision system.



SerDes Configurator

For the for the SerDes Configurator, please contact the Allied Vision Support team at www.alliedvision.com/en/about-us/contact-us/technical-support-repair-/rma.

For **Alvium FP3** cameras, see [FP3: DESER setup](#) on page 74 for example settings.

Alvium GM2 cameras are based on **Analog Devices GMSL**. Information on this interface is confidential. See [GM2: Basic information](#) on page 73 for basic information.

Power supply

Alvium FP3/GM2 cameras are powered via the interface cable. They must not be powered externally, using the I/O connector:



NOTICE

Damage to camera electronics

Alvium FP3/GM2 cameras use the same 10-pin TFM connector as Alvium G1 and G5/G5X cameras. But the connector on Alvium FP3/GM2 cameras must not be used as power input.

- Power Alvium FP3/GM2 coax models using the FAKRA coaxial connector, power STP models using the HSD STP connector.
- Use the 10-pin TFM connector only as power output and for I/O control.
- Use the 13870 power supply only for Alvium G1 and G5/G5X cameras.

Camera interfaces

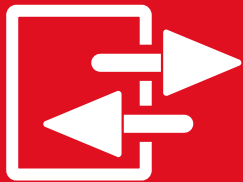

This chapter includes:

Precautions.....	70
Back panels for Coax and STP models	71
STP connector pin assignment.....	72
DESER to SER connection overview	72
GM2: Basic information	73
FP3: DESER setup	74
I/O description	82
Status LED.....	89

Precautions



NOTICE

Damage to camera electronics

Alvium FP3/GM2 cameras use the same 10-pin TFM connector as Alvium G1 and G5/G5X cameras. But the connector on Alvium FP3/GM2 cameras must not be used as power input.

- Power Alvium FP3/GM2 coax models using the FAKRA coaxial connector, power STP models using the HSD STP connector.
- Use the 10-pin TFM connector only as power output and for I/O control.
- Use the 13870 power supply only for Alvium G1 and G5/G5X cameras.



Malfunction by exceeding the maximum length for I/O cables

The maximum I/O cable length allowed for signal integrity on the I2C bus is 15 m. If the length for I/O cables exceeds 15 m, the camera is not recognized anymore.

Keep the length of I/O cables below 15 m.



Signal level

Consider this when you connect external devices to your camera, for example, to trigger lighting:

- The default signal level for isolated GPO2 is low at camera startup.
- The default signal level for non-isolated GPIO0 and GPIO1 is high at camera startup.

Use the **LineInverter** feature to configure I/Os and GPIOs for your needs.

Back panels for Coax and STP models



Interface connectors on cameras

FAKRA coaxial and HSD STP camera connectors can appear slightly rotated towards the housing edges. This is caused by sensor alignment. For the same reason, the gaps around the FAKRA coaxial and HSD STP connectors unit catch the eye.

Coax models: Back panel

		Description
	A	FAKRA coaxial connector
	B	I/O connector
	C	LED

Table 20: Coax models, back panel of the camera

STP models: Back panel

		Description
	A	Rosenberger D4S12H-40MA5-Z HSD STP connector
	B	I/O connector
	C	LED

Table 21: STP models, back panel of the camera

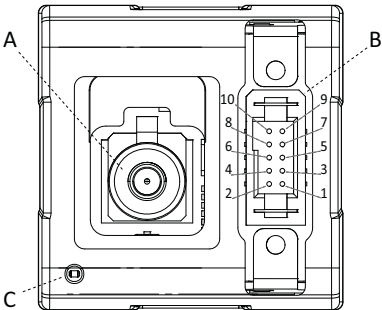
STP connector pin assignment

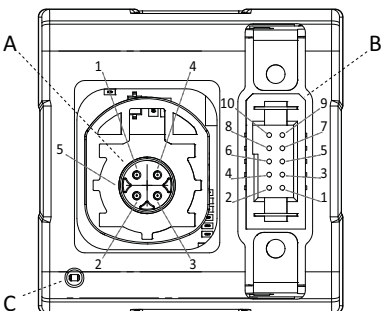

NOTICE

Damage to the camera and connected peripherals

If Alvium FP3/GM2 STP cameras are operated with incompatible cables, cameras and connected peripherals can be damaged.

- We recommend you to use only STP cables by Allied Vision.
- If you want to use third party STP cables, observe [HSD STP connector pin assignment](#) shown below for Alvium FP3/GM2 STP cameras.

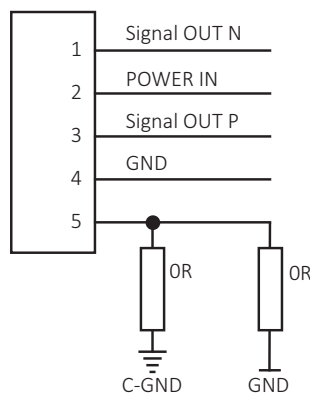

Figure 26: HSD STP connector pin assignment

DESER to SER connection overview



Terms: SER and DESER

DESER represents the deserializer, SER the serializer.

Figure 27 shows the signal flow for Alvium FP3/GM2 cameras in vision systems.

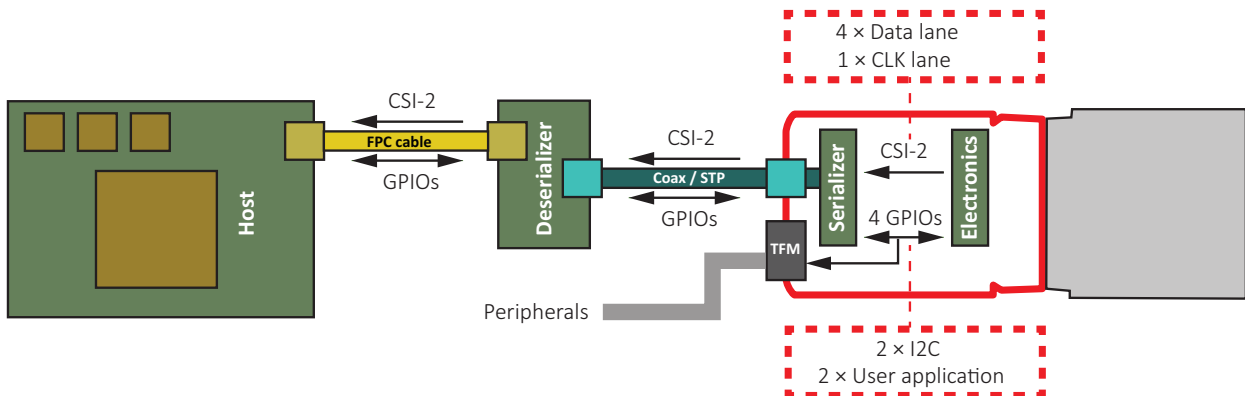

Figure 27: Signal flow for Alvium FP3/GM2 cameras in vision systems

GM2: Basic information

Alvium GM2 cameras are based on **Analog Devices GMSL2**.

Information on this interface is confidential. Alvium GM2 cameras use the Analog Devices MAX96717GTJ/VY+ serializer.



SerDes Configurator

We recommend you to use the **SerDes Configurator** to set up your GMSL2 vision system. Please contact the Allied Vision Support team at www.alliedvision.com/en/about-us/contact-us/technical-support-repair/-rma.



Example setup for GMSL2

The data sheet for the MAX96717 DPHY Evaluation Kit is a good example how to set up a GMSL2 system. See www.analog.com/media/en/technical-documentation/data-sheets/max96717-aak-evk-max96717r-ack-evk.pdf.



Deserializer board for Alvium GM2

For technical data and instructions, see the user guides for GMSL2 deserializer boards with Coax or STP at www.alliedvision.com/en/support/technical-documentation/alvium-csi-2-documentation.

Coax models: Bootstrapping for GM2

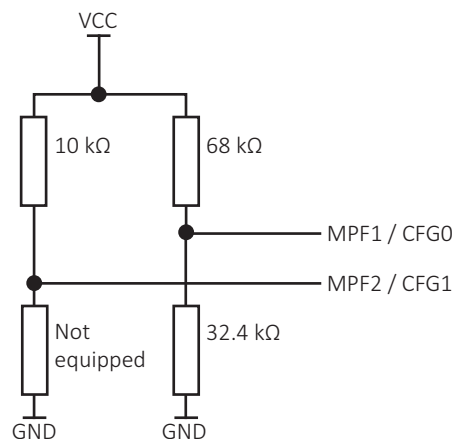

Figure 28: Coax models, bootstrapping for GM2

STP models: Bootstrapping for GM2

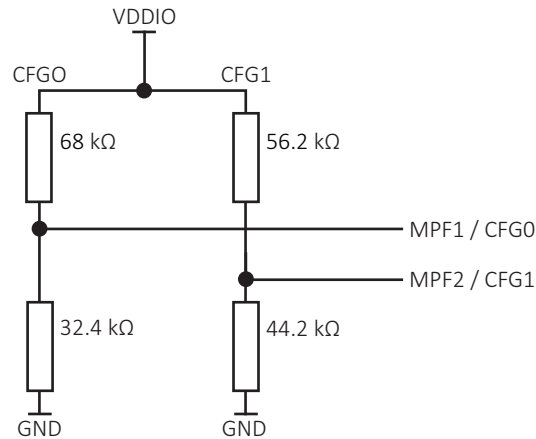

Figure 29: STP models, bootstrapping for GM2

FP3: DESER setup



SerDes Configurator

We recommend you to use the **SerDes Configurator** to set up your FPD-Link III vision system. Please contact the Allied Vision Support team at www.alliedvision.com/en/about-us/contact-us/technical-support-repair/-/rma.

Alvium FP3 cameras use the **Texas Instruments DS90UB953-Q1** serializer.



Better understanding of DESER and SER configuration

We recommend you to read the SNLA301 application note by **Texas Instruments**. The document explains a DESER-to-SER setup comprehensively, including requirements for cable length. You can download it from www.ti.com.



Serializer in Alvium FP3 cameras

For technical data and more instructions on the **Texas Instruments DS90UB953-Q1** serializer, see the manufacturer data sheet at www.ti.com.



Deserializer boards for Alvium FP3

For technical data and instructions, see the user guides for FPD-Link III deserializer boards with Coax or STP at www.alliedvision.com/en/support/technical-documentation/alvium-csi-2-documentation.

General requirements



Signal integrity

The complete power circuit on the deserializer has a huge impact on the signal integrity. This applies to PoC (Power over Coax) and Power over STP.

Use only cable lengths of maximum 15 m for Coax models and of maximum 10 m for FP3 STP and 8 m for GM2 STP models.

Power supply

Feature	Value
Power supply voltage	10,8 VDC to 26.4 VDC
Power consumption	Model specific See Power consumption on page 46.

Table 22: Power supply

Coaxial connections

Coaxial cables and connectors – general specifications

Feature	Value
Impedance	50 Ω
Frequency	≥ 5 GHz
Attenuation	≤ 75 dB / 100 m at 2.1 GHz
DC resistance	≤ 50 Ω / km

Table 23: Coaxial cables and connectors – general specifications

Coaxial cables and connectors – recommendations

Values for [Coax: GPIO latency](#) on page 76 have been tested successfully with **LEONI Dacar 302-3** cables.

Coax: GPIO latency

Data flow DESER to SER

Event	Value
Transition from signal low to high	Max. 1 μ s
Transition from signal high to low	Max. 1 μ s

Table 24: Coax, latency – Data flow DESER to SER

Data flow SER to DESER

Event	Value
Transition from signal low to high	Max. 0.2 μ s
Transition from signal high to low	Max. 0.2 μ s

Table 25: Coax, latency – Data flow SER to DESER



LEONI Dacar 302-3 cables

You can find technical data and cables offered by Allied Vision at www.alliedvision.com/en/products/accessories.



Reference systems

See [Validated systems](#) on page 94 for information.

Feature	Value
Reference cable used for tests	LEONI Dacar 302-3
Maximum cable length	~15 m
Connection points	Max. 2 connection points (4 connectors)
Standard connector coding	FAKRA Z-Coding (Water blue)

Table 26: Coaxial cables and connectors – recommendations

STP connections

STP cables and connectors – general specifications

Feature	Value
Conductor resistance (0,14 mm ² at 20 °C)	≤125 Ω/km
Testing voltage	1 kV AC
Operating voltage	30 VDC
Shielding effectiveness	≥55 dB (to 20 MHz) ≥40 dB (to 20 MHz to 1 GHz)
Capacitance (core-to-core)	≤50 pF/m
Characteristic impedance	100 ±6 Ω
Attenuation	≤124 dB / 100 m at 2.1 GHz

Table 27: STP cables and connectors – general specifications

STP cables and connectors – recommendations

Values for [STP: GPIO latency](#) on page 77 have been tested successfully with **LEONI Dacar 535** cables.

STP: GPIO latency

Data flow DESER to SER

Event	Value
Transition from signal low to high	Max. 1 μs
Transition from signal high to low	Max. 1 μs

Table 28: STP, latency – Data flow DESER to SER

Data flow SER to DESER

Event	Value
Transition from signal low to high	Max. 0.2 μs
Transition from signal high to low	Max. 0.2 μs

Table 29: STP, latency – Data flow SER to DESER

LEONI Dacar 535 cables

You can find technical data and cables offered by Allied Vision at www.alliedvision.com/en/products/accessories.

Reference systems

See [Validated systems](#) on page 94 for information.

Feature	Value
Reference cable used for tests	LEONI Dacar 535
Maximum cable length	~ 10 m (FP3 STP) ~ 8 m (GM2 STP)
Connection points	Max. 3 connection points (6 connectors)
Standard connector coding	HSD STP Z-Coding (Water blue)

Table 30: STP cables and connectors – recommendations

Serializer configuration

Coax models: Bootstrapping

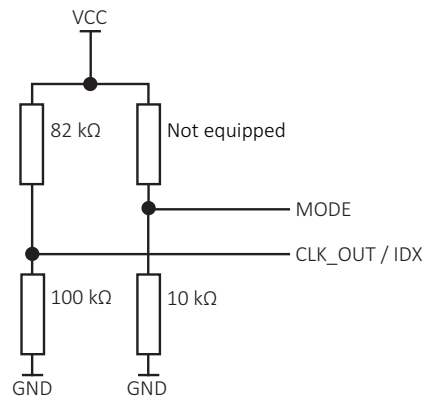

Figure 30: Bootstrapping

Mode

CSI-2 synchronous mode –
 FPD-Link III clock reference derived
 from the deserializer.

IDX

I2C 8-bit address: 0x30
 I2C 7bit address: 0x18

STP models: Bootstrapping

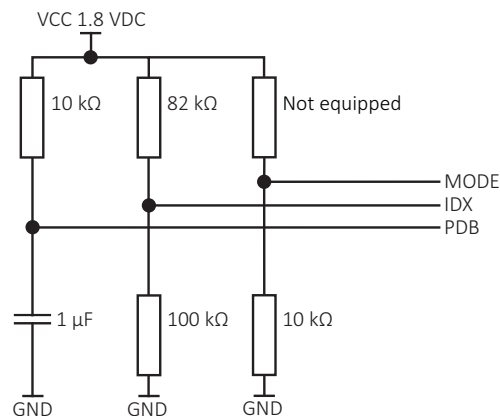

Figure 31: Bootstrapping

Mode

CSI-2 synchronous mode –
 FPD-Link III clock reference derived
 from the deserializer.

IDX

I2C 8-bit address: 0x30
 I2C 7bit address: 0x18

PDB

TurnON delay: 10 μs

Example register configuration

Table 31 shows a working example with DESER DS90UB954 by Allied Vision:

Register name	Register value	Description
DESER configuration		
FPD3_PORT_SEL	0x01	Enables register write for RX Port0.
SER_ALIAS	0x30	Sets the 7-bit remote serializer alias ID.
SLAVE_ID_INDEX0	0x78	Sets the SlaveID[0] add camera address: 0x78 7bit / 0x3C 8bit.
SLAVE_ID_MATCH0	0x78	Sets the SlaveAlias[0] add camera address: 0x78 7bit / 0x3C 8bit.
BCC_CONFIG	0x5E	Enables the I2C pass-through to the serializer: Ensure the decode matches!
FWD_CTL1	0x20	Enables forwarding for EN RX Port0.
FPD3_CAP	0x10	Enables CRC error flag from FPD-Link III encoder.
FPD3_ENC_CTL	0x03	Enables FPD-Link III encoder CRC.
CSI_PLL_CTL	0x00	Selects the CSI Transmitter speed (frequency) 00 : 1.6 Gbit/s serial rate
CSI_CTL	0x43	Enables initial skew calibration CSI_CONST_CLOCK = 1 Enables CSI-2 output
CSI_CTL2	0x41	Enables periodic CSI Skew-Calibration sequence
SFILTER_CFG	0xc9	Adjusts S filter values for the corresponding cable type and length. See the SNLA301 application note at www.ti.com .
AEQ_CTL2	0x9c	Configures the AEQ.
PORT_PASS_CTL	0x03	PORT_PASS_CTL = PASS_TRESHOLD = 3 = 3 Frames needed for pass
DESER configuration		
GENERAL_CFG	0x72	GENERAL_CFG = CONST_CLK=1 CSI_LANE_SEL = 0x3 CRC_TX_GEN_ENABLE = 1

Table 31: Example register configuration for DS90UB954



Deserializer

- **Deserializer chip** DS90UB954: For specifications, see <https://www.ti.com>.
- **Deserializer board** for Alvium FP3: For specifications and instructions, see the user guides for FPD-Link III deserializer boards with Coax or STP at www.alliedvision.com/en/support/technical-documentation/alvium-csi-2-documentation.

GPIO Configuration Examples

Data flow DESER to SER

Register address	Register value	Description (device)
DESER configuration		
0x4C [0]	0x1	Activates writing access for Port 0 (DESER)
0x6F [3:0]	0x0	Assigns GPIO0 (DESER) to GPIO2 (SER)
0x10 [0]	0x1	Disables pull down for GPIO0 (DESER)
SER configuration		
0x0E [2]	0x0	Disables GPIO2 input (SER)
0x6E[6]	0x1	Activates GPIO2 output (SER)

Table 32: GPIO Configuration – Data flow DESER to SER

Data flow SER to DESER

Register address	Register value	Description (device)
DESER configuration		
0x4C [0]	0x1	Activates writing access for Port 0 (DESER)
0x0F [0]	0x0	Disables input (DESER)
0x10 [0]	0x1	Activates output (DESER)
0x10 [4:2]	0x0	Selects RX Port 0 as output (DESER)
0x10 [7:5]	0x2	Selects SER GPO2 as output (DESER)
SER configuration		
0x33 [1:0]	0x3	Disables Forward channel GPIO (SER)

Table 33: GPIO Configuration – Data flow SER to DESER

I/O description



I/O connector

The I/O connector is 10-pin TFM connector type is an TFM-105-02-L-D-WT-K-TR.

We recommend using cables by Allied Vision. If you are going to manufacture your own cables, see SFSD, ISDF, or SFM series at www.samtec.com.



I/O cables

For I/O cables at different lengths with 10 Pin TFM to open ends, see www.alliedvision.com/en/support/accessory-documentation.

I/O connector pin assignment

The general purpose I/O port uses a 10-pin TFM connector on the camera side.

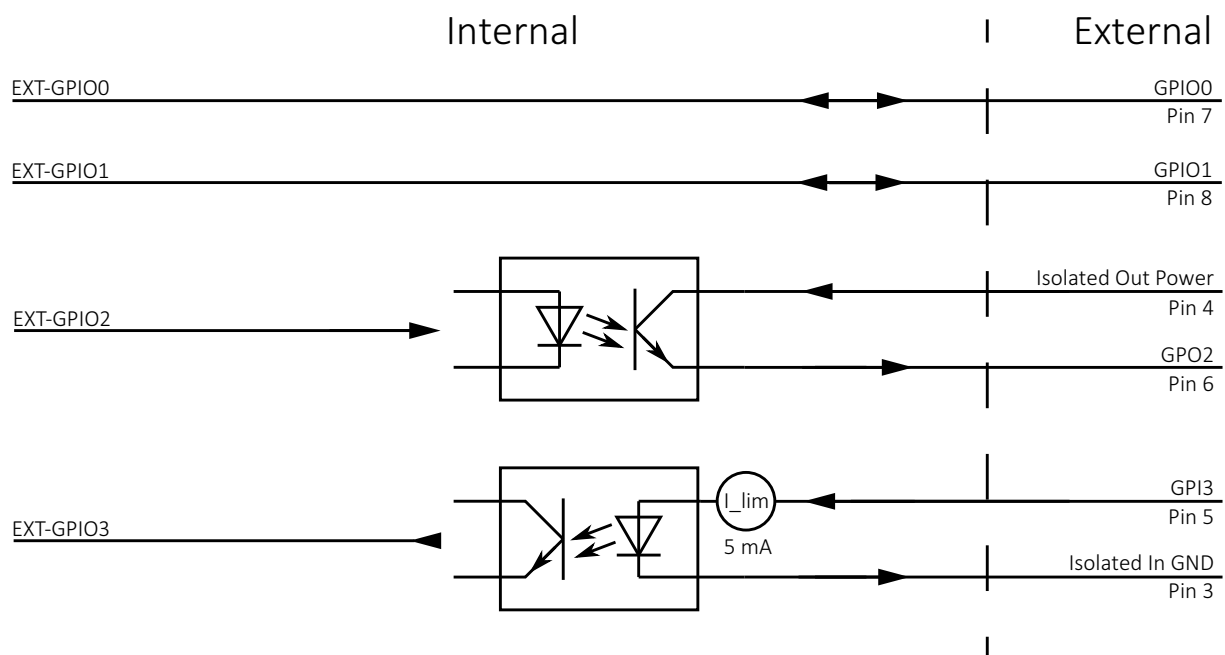

Figure 32: TFM I/O connector pin assignment

Pin assignment on Alvium FP3/GM2 cameras

Pin TFM	Signal	FP3: Pin Serializer ¹	GM2: Pin Serializer ²	Direction	Level	Description
1	PWR-GND	N.a. ²	N.a. ²	In	0 VDC	Supply Ground
2	PWR-OUT	N.a. ²	N.a. ²	Out	4.8 to 5.2 VDC at: max. 80 mA (12 VDC PoC voltage) max. 400 mA (24 VDC PoC voltage)	Power output
3	OPTO-IN-GND	N.a. ²	N.a. ²	In	0 VDC	Isolated input ground
4	OPTO-OUT-PWR	N.a. ²	N.a. ²	In	max. 30 VDC	Power for isolated output
5	GPI3	28	MFP3 (17)	In	$U_{in}(high) = 3.0$ to 24.0 V up to 36 VDC with $3.3\text{ k}\Omega$ ext. resistor in series $U_{in}(low) = 0$ to 1.0 V	Isolated Input User application Input only GPI3
6	GPO2	27	MFP0 (2)	Out	Open emitter, max. 20 mA	Isolated Output User application Output only GPIO2
7	GPIO0	24	MFP10 (6)	In/Out	$U_{in}(low) = -0.3$ to 0.8 VDC $U_{in}(high) = 2.0$ to 5.5 VDC $U_{out}(low) = 0$ to 0.4 VDC $U_{out}(high) = 2.4$ to 3.3 VDC at max. 20 mA	Non-isolated I/O (LVTTTL) I2C_SCL Commonly used by the camera, SER, and DESER. Can be accessed by the host.
8	GPIO1	23	MFP9 (5)	In/Out	See Pin 7, GPIO0	Non-isolated I/O (LVTTTL) I2C_SDA Commonly used by the camera, SER, and DESER. Can be accessed by the host.
9		N.a. ³	N.a. ³	Reserved		
10	C-GND	N.a. ³	N.a. ³	PWR	0 VDC	Chassis ground and shielding

¹ Texas Instruments DS90UB953-Q1 for FPD-Link III
¹ Analog Devices MAX96717GTJ/VY+ for GMSL2
³ Not applicable

Table 34: Pin assignment - TFM I/O connector and FP3 and GM2 serializers

I/Os and GPIOs

Isolated input description

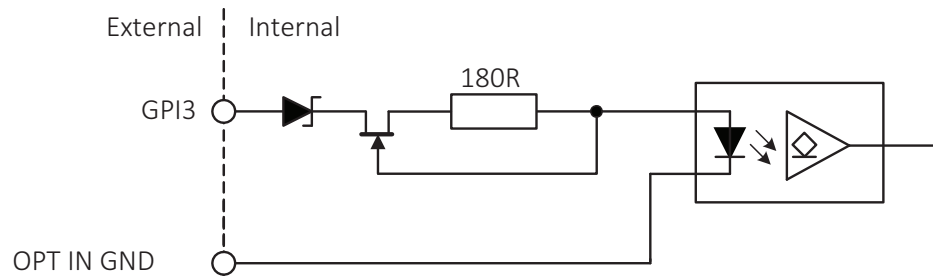

Figure 33: Input block diagram

The input can be connected directly to the system for voltages up to 24 VDC. An external resistor is not necessary.

Levels

Parameter	Value
U_{in} (low)	0 to 1.0 V
U_{in} (high)	3 to 24 V
Current (constant-current source)	3 to 4 mA

Table 35: Input parameters

Minimum pulse width

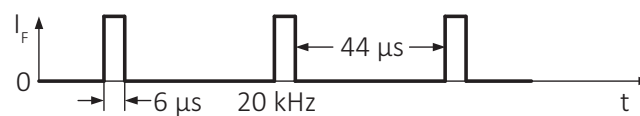

Figure 34: Minimum pulse width

Test conditions

The input signal was driven with 3.3 V and no external additional series resistor.

Isolated output description

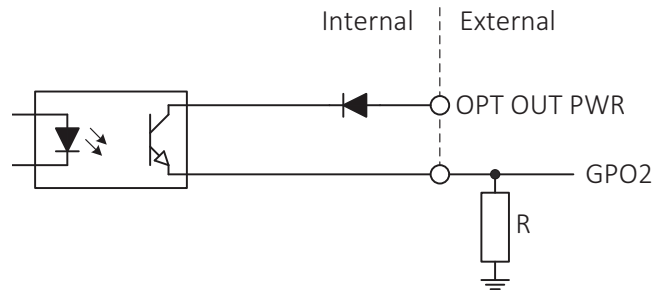

Figure 35: Output block diagram

Levels



NOTICE

Damage to the camera by high output current or voltage

Exceeding the maximum output voltage or current can damage the camera. Keep maximum output voltage below 24 VDC and output current below 20 mA.

Isolated out power	Resistor value ¹	
5 V	1.0 kΩ	at ~ 5 mA minimum required current draw
12 V	2.4 kΩ	
24 V	4.7 kΩ	

¹ A resistor is required when GPO2 is connected to a device with a high impedance < 5 mA draw.

Table 36: Isolated out power and external resistor

Switching times

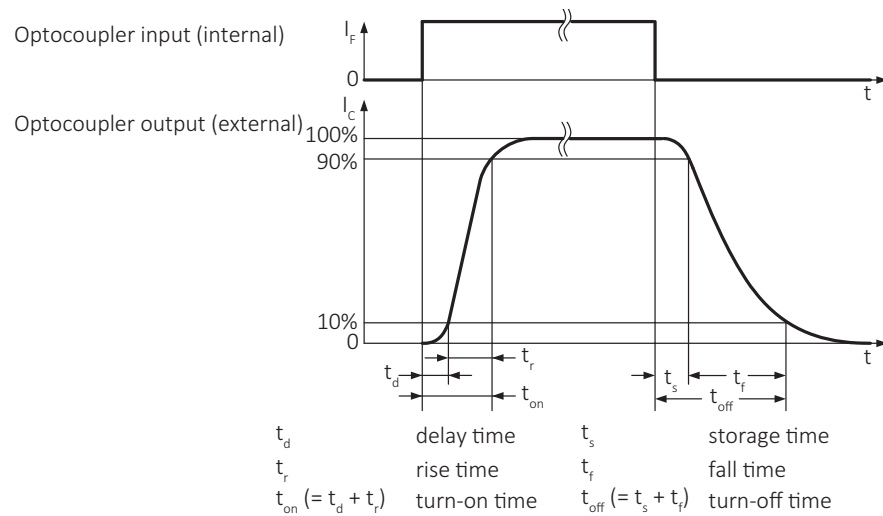

Figure 36: Output switching times

Parameter and value	
$t_d \approx 1 \mu\text{s}$	$t_s \approx 26 \mu\text{s}$
$t_r \approx 1 \mu\text{s}$	$t_f \approx 21 \mu\text{s}$
$t_{on} = t_d + t_r \approx 2 \mu\text{s}$	$t_{off} = t_s + t_f \approx 47 \mu\text{s}$ (t_{off} can deviate by $\pm 5 \mu\text{s}$)

Table 37: Output parameters

Test conditions

Output: external 2.4 k Ω resistor to GND, isolated out power set to 12 V.



Higher external values increase the times in the previous table.

Non-isolated GPIOs description

The camera has two non-isolated GPIOs that are used for I2C communication. The internal pull-up resistor has $430\ \Omega$.

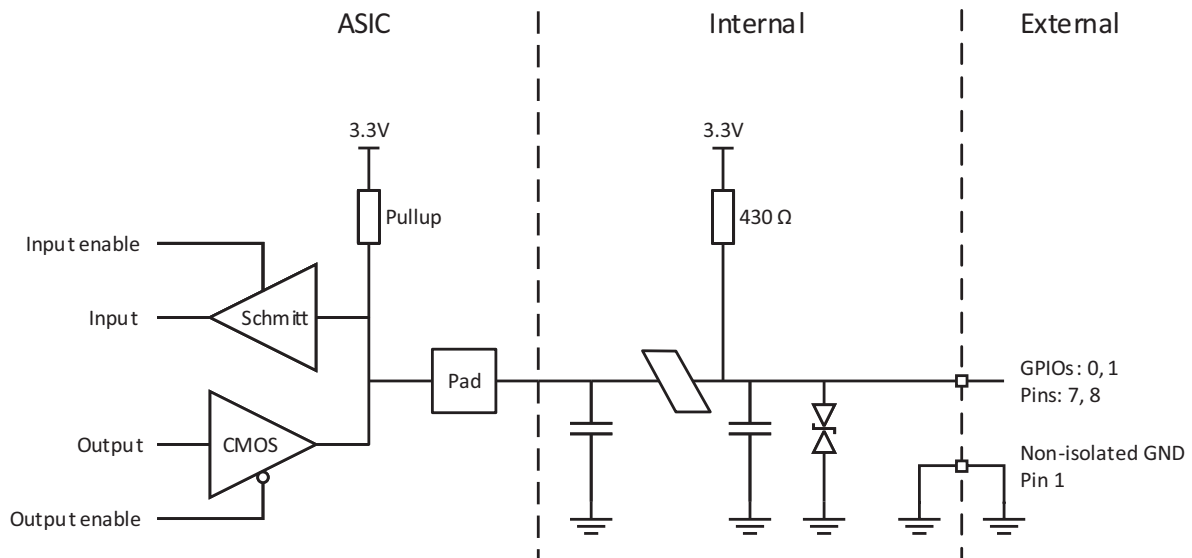

Figure 37: GPIOs block diagram

Input levels

The GPIOs can be connected directly to the system controlling the camera for voltages up to 5.5 VDC. An external resistor is not necessary.



NOTICE

Damage to the camera by high input voltage

Exceeding the maximum input voltage can damage the camera.

Keep maximum input voltage below 5.5 VDC.

Parameter	Value
U_{in} (low)	-0.3 to 0.8 VDC
U_{in} (high)	2.0 to 5.5 VDC
Undefined levels	0.8 to 2.0 VDC

Table 38: GPIOs as input, voltage levels

Output levels



NOTICE

Damage to the camera by high output current

The camera can be damaged when connected to a device that exceeds the specified maximum current or voltage. Keep the maximum current below 12 mA per output.

Parameter	Value
External output voltage U_{out} (low, Off state)	0 to 0.4 VDC
External output voltage U_{out} (high, On state)	2.4 to 3.3 VDC
Undefined levels	0.4 to 2.4 VDC
Maximum external output voltage	3.3 VDC
Maximum output current	12 mA

Table 39: GPIOs as output, current and voltage levels



Output voltage for U_{out} (high) = On state

The voltage level in the On state depends on the load current. Higher currents yield lower voltage.

Status LED

Alvium FP3/GM2 cameras have a green status LED. The following table describes the flashing pattern indicating different events. Inverse flashing: If the LED is already on, it is switched off for a short time.

Normal operation.



LED codes	Behavior	Status
	Continuously active	Power on or idle state
	Irregular flashing	Command or image traffic, such as for camera startup
	Four short flashes and code sequence	Error state

Table 40: LED codes



LED codes on first series models

On first series Coax and STP models, the LED (a) does not behave fully as described in Table 40. Until this will be fixed by a future firmware, please look at the internal LED (b) that can be seen through the gap of the housing.



Figure 38: External LED (a) and internal LED (b) on a Coax model

Error conditions

If the camera signals an error, try the following to get the camera back to normal operation:

- Restart the camera.
- Should this fail, please contact support at www.alliedvision.com/en/about-us/contact-us/technical-support-repair/-rma.

Triggering



For information on

- Availability of triggering controls for CSI-2
- Trigger signal flow
- Trigger latency
- Triggering with rolling shutter cameras

Please see the Alvium CSI-2 Cameras User Guide at

www.alliedvision.com/en/support/technical-documentation/alvium-csi-2-documentation.

Firmware update



Alvium FP3/GM2 are compatible with firmware version V00.11.00.9cf0c21e or higher. Previous versions do not support these cameras.

Image data flow



Please see the Alvium CSI-2 Cameras User Guide at

www.alliedvision.com/en/support/technical-documentation/alvium-csi-2-documentation.

Performance



This chapter includes:

Validated systems..... 94

For information on

- Image transfer with rolling shutter cameras
- Frame rate jitter
- Value changes by control interdependencies
- Dark current compensation
- Shutter types affecting image readout

Please see the Alvium CSI-2 Cameras User Guide at

www.alliedvision.com/en/support/technical-documentation/alvium-csi-2-documentation.

Validated systems



Deserializer boards for Alvium FP3/GM2

- Alvium FP3 Coax: 19559 Deserializer Board FPD-Link III Coax to CSI-2
- Alvium FP3 STP: 19502 Deserializer Board FPD-Link III STP to CSI-2
- Alvium GM2 Coax: 19503 Deserializer Board GMSL2 Coax to CSI-2
- Alvium GM2 STP: 19558 Deserializer Board GMSL2 STP to CSI-2

You can find these products at www.alliedvision.com/en/products/accessories.

FP3: Hardware setups

- Setup 1
 - Auvideo JNX30 carrier board
 - NVIDIA Jetson Xavier NX SoM
 - Alvium CSI-2 Adapter for Auvideo JNX30 Carrier Board (see note below)
 - **Coax:** 19559 Deserializer Board FPD-Link III Coax to CSI-2 (with Texas Instruments DS90UB954 deserializer)
 - **STP:** 19502 Deserializer Board FPD-Link III STP to CSI-2 (with Texas Instruments DS90UB954 deserializer)
 - Alvium FP3 Coax camera



Alvium CSI-2 Adapter for Auvideo JNX30 Carrier Board

The 38373 Alvium CSI-2 Adapter for Auvideo JNX30 Carrier Board is manufactured and offered by Auvideo. For information, see <https://auvideo.eu>.

- Setup 2
 - NVIDIA Jetson AGX Orin DevKit
 - 19616 Adapter Board for NVIDIA Jetson AGX Orin DevKit (under development)
 - **Coax:** 19559 Deserializer Board FPD-Link III Coax to CSI-2 (with Texas Instruments DS90UB954 deserializer)
 - **STP:** 19502 Deserializer Board FPD-Link III STP to CSI-2 (with Texas Instruments DS90UB954 deserializer)
 - Alvium FP3 Coax camera

GM2: Hardware setups

- Setup 1
 - NVIDIA Jetson AGX Orin DevKit
 - 19616 Adapter Board for NVIDIA Jetson AGX Orin DevKit (under development)
 - **Coax:** 19503 Deserializer Board GMSL2 Coax to CSI-2 (with Analog Devices MAX96716AGTM/VY+T deserializer)
 - **STP:** 19558 Deserializer Board GMSL2 STP to CSI-2 (with Analog Devices MAX96716AGTM/VY+T deserializer)
 - Alvium GM2 Coax camera
- Setup 2
 - NVIDIA Jetson Xavier NX DevKit
 - 14948 Adapter Board for NVIDIA Jetson Nano and Jetson Xavier NX DevKit
 - **Coax:** 19503 Deserializer Board GMSL2 Coax to CSI-2 (with Analog Devices MAX96716AGTM/VY+T deserializer)
 - **STP:** 19558 Deserializer Board GMSL2 STP to CSI-2 (with Analog Devices MAX96716AGTM/VY+T deserializer)
 - Alvium GM2 Coax camera

FP3/GM2 Coax: Software setup

This software setup was used with FP3 Coax and GM2 Coax:

- NVIDIA Jetpack 5.1.0
- Allied Vision (MIPI) CSI-2 driver for NVIDIA Jetson 5.1.0
- Allied Vision V4L2 Viewer 2.1
- Vimba X 2023-1

Bandwidth

The available bandwidth depends on your individual imaging system, including such as hardware components and register settings.

Deserializers have a decisive impact on performance and bandwidth. Please contact the Allied Vision Support team to benefit from our experience.



Contact Allied Vision Support

For more information, you can contact the Allied Vision Support team at www.alliedvision.com/en/about-us/contact-us/technical-support-repair-/-rma.

Index

A	
Allied Vision contact	19
B	
back panel	
Coax models	71
STP models	71
bandwidth	46
C	
camera connectors	
Coax models	71
STP models	71
camera identification	30
Code Z (water blue)	42
compliance	30
connecting FAKRA coaxial cables	64
connecting HSD STP cables	66
connectors	69
copyright	32
D	
DESER	
configuring	68
connections to SER	72
setup for FP3 cameras	74
dimensions	47
document	
conventions	26
history	25
overview	15
terms and acronyms	27
E	
ESD	34
F	
FAKRA	
connecting cables	64
FCC	30
firmware update	91
FPD-Link III standard	41
frame rates	46
G	
general safety notes	32
GenICam	41
GMSL2 definition	41
ground loops	37
H	
hardware assembly	
camera mounting	58
connecting FAKRA coaxial cables	64
connecting HSD STP cables	66
lens mounting	60
heat dissipation	33
I	
I/Os, GPIOs	
Coax latencies	76
connector pin assignment	82
description	84
FP3/GM2 serializer pin assignment	83
STP latencies	77
interfaces	69
IP class	42
IR cut filter	53
L	
LED codes	89
lens mounts	53
lenses	54
maximum protrusion	39
mounting	60
M	
mass	47
MIPI CSI-2	41
model ID	30
O	
operating temperature	46
P	
power consumption	46
R	
reference systems	94
relative humidity	46
S	
safety	2, 33
camera power	37
connectors and cables	36
electrical connections	35
ground loops	37
heat dissipation	33
lens mounts	33
maximum protrusion	39
no hot-plugging	36

optical components	37	mounting	61
sensor	38	specifications	40
STP cables	36	status LEDs	89
strain relief	35	storage temperature	46
sensor cleanliness (definition)	38	STP	
sensor handling	38	connecting cables	66
SER		connector pin assignment	72
configuring	68	safety	36
connections to DESER	72	support	19
SerDes		T	
configuring	68	technical drawings	47, 50
connection overview	72	triggering	90
SerDes technology	41	troubleshooting	93
shipping contents	17	V	
shock and vibration	42	V4L2	42
signal quality	36		
S-Mount lenses			