

## ALVIUM MIPI CSI-2 CAMERAS

# Adapter Board for NVIDIA Jetson AGX Xavier and TX2 User Guide

V1.1.4

**Quick links**

- [This document at a glance](#) on page 15
- [Contact us](#) on page 17
- [Contents](#) on page 18

# Read before use

## EN - English

### Safety

Before using the product, read these safety instructions. Observe the warnings at all times. Use the product only as stated in the [Intended use](#) on page 25.

**CAUTION****Risk of burns**

The product in operation can reach temperature levels which could cause burns.

**CAUTION****Risk of cuts by sharp edges**

The product can have sharp edges.

### Intended use

Intended use of Allied Vision product is the integration into vision systems by professionals. All Allied Vision product is sold in a B2B setting.

## DA - Dansk

### Sikkerhed

Læs sikkerhedsanvisningerne, før produkt bruges. Overhold alle advarsler. Brug kun produkt som anført i [Intended use](#) på side 25.



#### FORSIGTIG

##### Forbrændingsfare

Når produkt bruges, kan det blive meget varmt og forårsage forbrændinger.



#### FORSIGTIG

##### Fare for skarpe kanter

Produktet kan have skarpe kanter.

### Tilsigtet brug

Allied Vision produktets tilsigtede brug er en indbygning i et visionssystem, udført af fagfolk. Alle Allied Vision produkter sælges i B2B.

## DE - Deutsch

### Sicherheit

Bevor Sie das Produkt benutzen, lesen Sie diese Sicherheitshinweise. Beachten Sie diese Hinweise immer. Verwenden Sie das Produkt nur wie beschrieben in [Intended use](#) auf Seite 25.



#### VORSICHT

##### **Gefahr von Verbrennungen**

Im Betrieb kann das Produkt Temperaturen erreichen, die zu Verbrennungen führen.



#### VORSICHT

##### **Schnitte durch scharfe Kanten**

Das Produkt kann scharfe Kanten haben.

### Bestimmungsgemäßer Gebrauch

Allied Vision Produkte sind bestimmt für die Integration in Bildverarbeitungssysteme durch Fachpersonal. Alle Allied Vision Produkte werden in einer B2B-Umgebung verkauft.

## ES - Español

### Seguridad

Antes de utilizar el producto lea estas instrucciones de seguridad. Observe las advertencias en todo momento. Utilice el producto solo tal y como se estipula en el [Intended use](#) en la página 25.



#### ATENCIÓN

##### Riesgo de quemaduras

El producto en funcionamiento puede alcanzar temperaturas que podrían provocar quemaduras.



#### ATENCIÓN

##### Riesgo de cortes por bordes afilados

El producto puede tener bordes afilados.

### Uso previsto

El uso previsto del producto Allied Vision es la integración en el sistema de visión por parte de profesionales. Todos los productos Allied Vision se venden dentro de una relación B2B.

## FI - Suomi

### Turvallisuus

Lue nämä turvallisuusohjeet ennen tuotteen käyttöä. Noudata tuotetta joka hetki. Käytä tuotteen ainoastaan kohdassa [Intended use](#) sivulla 25 kuvatulla tavalla.



#### HUOMIO

##### Palovammojen vaara

Käytössä olevan tuotteen saavuttamat lämpötilatasot voivat aiheuttaa palovammoja.



#### HUOMIO

##### Terävien reunojen aiheuttama viiltovaara

Tuotteessa voi olla teräviä reunoja.

### Käyttötarkoitus

Allied Vision-tuotteen käyttötarkoitus on integrointi kuvajärjestelmiin ammattilaisten toimesta. Kaikki Allied Vision-tuotteet myydään B2B-ympäristössä.

## FR - Français

### Sécurité

Veuillez lire ces consignes de sécurité avant d'utiliser le produit. Respectez continuellement les avertissements. Utilisez le produit uniquement comme indiqué sous [Intended use](#), page 25.



#### ATTENTION

##### Risque de brûlures

Le produit en service peut atteindre des niveaux de température susceptibles d'entraîner des brûlures.



#### ATTENTION

##### Risque de coupures sur des bords tranchants

Le produit peut présenter des bords tranchants.

### Utilisation prévue

L'utilisation prévue du produit Allied Vision est son intégration dans des systèmes de vision par le soin de professionnels. Tout produit Allied Vision est vendu dans un cadre B2B.

## עברית - HE

### בטיחות

לפני השימוש במוצר, עליך לקרוא את הוראות הביטחון האלו. עליך לממש הוראות ביטחון אלו תמיד. השימוש במצלמה הוא רק לפי מה שכתוב ב"כוונת השימוש" (Intended use בעמוד 25).

#### זהירות

##### סכנת כווייה

בזמן הפעלת המוצר עלולות לעלות טמפרטורות גבוהות, שיכולות לגרום לכוויות.



#### זהירות

##### סכנת חתכים על ידי קצוות חדים

למוצר יכולים להיות קצוות חדים.



### שימוש מיועד

מוצרי AlliedVision מיועדים לשילוב במערכות ממוחשבת לעיבוד צילומים ע"י אנשי מקצוע. כל מוצרי AlliedVision נמכרים לשימוש בסביבת B2B.



## IT - Italiano

### Sicurezza

Leggere queste istruzioni per la sicurezza prima di utilizzare il prodotto. Osservare sempre tutte le avvertenze. Utilizzare il prodotto come descritto alla sezione [Intended use](#) a pagina 25.



#### ATTENZIONE

##### **Pericolo di ustioni**

Durante il funzionamento, il prodotto può raggiungere temperature elevate che possono essere causa di ustioni.



#### ATTENZIONE

##### **Pericolo di tagliarsi sui bordi affilati**

I bordi del prodotto lente possono essere affilati.

### Uso previsto

Il prodotto Allied Vision è concepito per essere integrato in sistemi di monitoraggio in campo professionale. Tutti i prodotti Allied Vision sono venduti in uno scenario B2B.

## JA – 日本語

### 安全性

本製品を使用する前に、この安全ガイドをお読みください。警告を必ず守ってください。必ず21ページのIntended use 25 ページに従って使用してください。



#### 注意

##### やけどの危険性

作動中のカメラは、やけどを引き起こす温度まで熱くなる恐れがあります。



#### 注意

##### な端部で切り傷の危険性

本製品には鋭利な部分がある場合があります。

### 用途

Allied Vision製品は、専門家が視覚装置に統合することを意図したものです。すべてのAllied Vision製品は、企業間取り引き用に販売されています。

## NL - Nederlands

### Veiligheid

Lees deze veiligheidsinstructies voordat u het product gebruikt. Neem deze waarschuwingen altijd in acht. Gebruik het product uitsluitend, zoals aangegeven in het [Intended use](#) op pagina 25.



#### VOORZICHTIG

##### **Risico van verbranding**

Het gebruikte product, kan temperatuurwaarden bereiken die brandwonden kunnen veroorzaken.



#### VOORZICHTIG

##### **Risico van snijwonden door scherpe randen**

Het product kan scherpe randen hebben.

### Beoogd gebruik

Het beoogde gebruik van het Allied Vision-product is de integratie in optische systemen door professionals. Alle Allied Vision-producten worden verkocht in de B2B-markt.

## NO - Norsk

### Sikkerhet

Les disse sikkerhetsinstruksene før du bruker produkt. Følg advarslene til en hver tid. Bruk kun produkt i samsvar med [Intended use](#) på side 25.



#### FORSIKTIG

##### Risiko for brannskader

Produktet i bruk kan nå temperaturnivåer som kan forårsake brannskader.



#### FORSIKTIG

##### Risiko for kutt fra skarpe kanter

Produktet kan ha skarpe kanter.

### Tiltenkt bruk

Den tiltenkte bruken av Allied Vision-produktet er integrering i visjonssystemer av profesjonelle. Alle Allied Vision-produkter selges i en forretning til forretning-situasjon.

## SV - Svenska

### Säkerhet

Läs igenom säkerhetsinstruktionerna innan du använder produkten. Var hela tiden särskilt uppmärksam på varningarna. Använd enbart produkten på det sätt som anges i [Intended use](#) på sida 25.



#### VARNING

##### Risk för brännskada

Produkten i drift kan komma upp i temperaturer som kan orsaka brännskador.



#### VARNING

##### Risk för skärsår från vassa kanter

Produkten kan ha vassa kanter.

### Avsedd användning

Den avsedda användningen av Allied Vision-produkter är integrering i visionssystem av fackmän. Samtliga Allied Vision-produkter säljs i en B2B-miljö.

## ZH - 简体中文版

### 安全需知

在使用产品之前，请阅读这些安全说明。请务必遵守相关警告和 [Intended use](#) 于第 25 页。



#### 注意事项

##### 烫伤风险

在产品运行过程中，温度可能会上升，导致烧伤的危险。



#### 注意事项

##### 锋利边缘割伤的风险

产品可能有锋利的边缘。

### 预期用途

Allied Vision 产品的预期用途是由专业人士整合到视觉系统中。所有 Allied Vision 的产品均通过 B2B 渠道销售。

# This document at a glance



This chapter includes:

|                              |    |
|------------------------------|----|
| Shipping contents.....       | 16 |
| What else do you need? ..... | 16 |

**Read this document carefully**

Learn to use adapter boards in the most safe and efficient way and avoid damage to your embedded system.

## Shipping contents

The delivery consists of the adapter board for NVIDIA Jetson AGX Xavier and TX2 Developer Kits with no other components.

**Flexible printed circuit (FPC) cable is not included**

The FPC cable to connect the adapter board to the camera is not included.

## What else do you need?

**Technical information and ordering of Allied Vision products**

- For all information about Alvim CSI-2 cameras and accessories, see [www.alliedvision.com/en/support/technical-documentation/alvim-csi-2-documentation](http://www.alliedvision.com/en/support/technical-documentation/alvim-csi-2-documentation).
- Please contact your Allied Vision Sales representative for ordering and for additional information on hardware options for Alvim cameras.

**Technical information on NVIDIA Jetson embedded boards**

For information on NVIDIA Jetson embedded boards, see [www.nvidia.com/en-us/autonomous-machines/embedded-systems](http://www.nvidia.com/en-us/autonomous-machines/embedded-systems)



# Contact us

## Website, email

### General

[www.alliedvision.com/en/contact](http://www.alliedvision.com/en/contact)

[info@alliedvision.com](mailto:info@alliedvision.com)

### Distribution partners

[www.alliedvision.com/en/avt-locations/avt-distributors](http://www.alliedvision.com/en/avt-locations/avt-distributors)

### Support

[www.alliedvision.com/en/support](http://www.alliedvision.com/en/support)

[www.alliedvision.com/en/about-us/contact-us/technical-support-repair-/rma](http://www.alliedvision.com/en/about-us/contact-us/technical-support-repair-/rma)

## Offices

### Europe, Middle East, and Africa (Headquarters)

Allied Vision Technologies GmbH

Taschenweg 2a

07646 Stadtroda, Germany

T// +49 36428 677-0 (Reception)

T// +49 36428 677-230 (Sales)

F// +49 36428 677-28

### North, Central, and South America, Canada

Allied Vision Technologies Canada Inc.

300 – 4621 Canada Way

Burnaby, BC V5G 4X8, Canada

T// +1 604 875 8855

### USA

Allied Vision Technologies, Inc.

102 Pickering Way- Suite 502

Exton, PA 19341, USA

Toll-free// +1-877-USA-1394

T// +1 978 225 2030

### Asia-Pacific

#### China

Allied Vision Technologies Shanghai Co Ltd.

B-510, Venture International Business Park

2679 Hechuan Road

Minhang District, Shanghai 201103

People's Republic of China

T// +86 21 64861133

#### Japan

Allied Vision Technologies

Yokohama Portside Bldg. 10F

8-1 Sakae-cho, Kanagawa-ku

Yokohama-shi, Kanagawa, 221-0052

T// +81 (0) 45 577 9527

#### Singapore

Allied Vision Technologies Asia Pte. Ltd

82 Playfair Rd, #07-01 D'Lithium

Singapore 368001

T// +65 6634 9027

# Contents

|  |    |
|--|----|
| Read before use .....                                | 2  |
| This document at a glance .....                      | 15 |
| Shipping contents .....                              | 16 |
| What else do you need? .....                         | 16 |
| Contact us .....                                     | 17 |
| Document history and conventions .....               | 20 |
| Document history .....                               | 21 |
| Conventions used in this user guide .....            | 22 |
| Typographical styles .....                           | 22 |
| Symbols and notes .....                              | 22 |
| Component naming .....                               | 23 |
| Compliance, safety, and intended use .....           | 24 |
| Compliance notifications .....                       | 25 |
| Intended use .....                                   | 25 |
| Copyright and trademarks .....                       | 25 |
| Your safety .....                                    | 26 |
| Handling hot adapter boards .....                    | 26 |
| Sharp edges .....                                    | 26 |
| Product safety .....                                 | 26 |
| Embedded systems .....                               | 26 |
| Electrical connections .....                         | 26 |
| Electrostatic discharge (ESD) .....                  | 27 |
| Camera power .....                                   | 27 |
| FPC connectors .....                                 | 27 |
| MIPI CSI-2 FPC cables .....                          | 28 |
| Specifications .....                                 | 30 |
| General specifications .....                         | 31 |
| PCB and PCBA number .....                            | 31 |
| Dimensions and PCB layout .....                      | 32 |
| Electronic schematics .....                          | 33 |
| Camera power .....                                   | 35 |
| I/O connections .....                                | 35 |
| Using the adapter board .....                        | 36 |
| Embedded system accessories .....                    | 37 |
| Connecting FPC cables to Hirose FPC connectors ..... | 37 |

|                                     |    |
|-------------------------------------|----|
| Installing adapter boards .....     | 39 |
| Connecting the embedded board ..... | 39 |
| Connecting the camera .....         | 40 |
| Connecting USB power .....          | 40 |
| Connecting the I/Os .....           | 41 |

# Document history and conventions



This chapter includes:

|  |    |
|--|----|
| Document history .....                   | 21 |
| Conventions used in this user guide..... | 22 |
| Component naming .....                   | 23 |

## Document history

| Version | Date        | Remarks   |
|---------|-------------|---|
| V1.1.4  | 2024-Nov-21 | Updated temperature vales in <a href="#">General specifications</a> on page 31.   |
| V1.1.3  | 2024-Jul-15 | Updated addresses in <a href="#">Contact us</a> on page 17.   |
| V1.1.2  | 2024-Mar-15 | Added UKCA symbol in <a href="#">Compliance notifications</a> on page 25.   |
| V1.1.1  | 2023-Aug-24 | <ul style="list-style-type: none"> <li>Updated notes for requirements with USB power supplies.</li> <li>Applied editorial changes.</li> </ul>   |
| V1.1.0  | 2023-Jun-06 | <ul style="list-style-type: none"> <li>Updated product images.</li> <li>Added <a href="#">Read before use</a> on page 2.</li> <li>Added 18947 MIPI CSI-2 cable to <a href="#">General specifications</a> on page 31.</li> <li>Removed safety note for desoldering resistors in <a href="#">Product safety</a> on page 26 and instructions from <a href="#">Connecting the I/Os</a> on page 41.</li> <li>Corrected connector IDs in the introduction text for <a href="#">Table 5</a> on page 43.</li> <li>Applied editorial changes.</li> </ul> |
| V1.0.3  | 2021-Dec-01 | <ul style="list-style-type: none"> <li>Added notes about housings to avoid injuries by heat.</li> <li>Added contents about <a href="#">PCB and PCBA number</a> on page 31.</li> <li>Applied editorial changes.</li> </ul>   |
| V1.0.2  | 2020-Sep-02 | Added information on I/O specifications in <a href="#">I/O connections</a> on page 35 and on connecting I/Os in <a href="#">Connecting the I/Os</a> on page 41.   |
| V1.0.1  | 2020-Jun-02 | <ul style="list-style-type: none"> <li>Added the diameter for the mounting holes of the adapter board.</li> <li>Applied editorial changes.</li> </ul>   |
| V1.0.0  | 2019-Nov-21 | Release version   |

Table 1: Document history

# Conventions used in this user guide

To give this user guide an easily understood layout and to emphasize important information, the following typographical styles and symbols are used:

## Typographical styles

| Style                                    | Function  |
|--|---|
| <b>Emphasis</b>                          | Highlighting important things                   |
| <a href="#">Web links and references</a> | Links to webpages and internal cross references |

Table 2: Typographical styles

## Symbols and notes



### CAUTION

#### Risk of burns

Precautions are described.



### CAUTION

#### Risk of cuts by sharp edges

Precautions are described.



### NOTICE

#### Material damage

Precautions are described.



#### Practical tip

Additional information helps to understand or ease handling the camera and components.



#### Additional information

Web link or reference to an external source with more information is shown.

## Component naming

Components described in this user guide are not defined by common standards. Therefore, naming must be accurate to avoid misconceptions. Because naming is lengthy, reading is difficult. Simplified terms are used in this document.

| Long version   | Short version used in this document   |
|--|---------------------------------------|
| Adapter Board for NVIDIA Jetson AGX Xavier Developer Kit and for NVIDIA Jetson TX2 Developer Kit | Adapter for Jetson AGX Xavier and TX2 |
| MIPI CSI-2 <sup>1</sup> adapter board  | Adapter board                         |
| MIPI CSI-2 FPC (flexible printed circuit) cable  | FPC cable                             |
| <sup>1</sup> MIPI CSI-2 Mobile Industry Processor Interface Camera Serial Interface 2            |                                       |

*Table 3: MIPI CSI-2 adapter board naming*

# Compliance, safety, and intended use



This chapter includes:

|                                |    |
|--------------------------------|----|
| Compliance notifications ..... | 25 |
| Intended use .....             | 25 |
| Copyright and trademarks ..... | 25 |
| Your safety.....               | 26 |
| Product safety .....           | 26 |



## Compliance notifications



National regulations on disposal must be followed.

## Intended use

Allied Vision's objective is the development, design, production, maintenance, servicing and distribution of digital cameras and components for image processing. We are offering standard products as well as customized solutions.

Intended use of Allied Vision product is the integration into Vision systems by professionals. All Allied Vision product is sold in a B2B setting.

Allied Vision isn't a legal manufacturer of medical product. Instead, Allied Vision cameras and accessories may be used as components for medical product after design-in by the medical device manufacturer and based on a quality assurance agreement (QAA) between Allied Vision (supplier) and medical device manufacturer (customer). Allied Vision's duties in that respect are defined by ISO 13485, clause 7.2 (customer-related processes, equivalent to ISO 9001, clause 8.2).

## Copyright and trademarks

All text, pictures, and graphics are protected by copyright and other laws protecting intellectual property. All content is subject to change without notice.

All trademarks, logos, and brands cited in this document are property and/or copyright material of their respective owners. Use of these trademarks, logos, and brands does not imply endorsement.

Copyright © 2024 Allied Vision Technologies GmbH. All rights reserved.

## Your safety

This section informs about issues related to your personal safety. Descriptions explain how to avoid hazards and use adapter boards safely.

### Handling hot adapter boards

Electrical components of adapter boards get hot during operation.

Before operation, include adapter boards in housings that disable any contact to hot components.

### Sharp edges

The edges of PCBs (printed circuit boards) and the assembled components can be sharp. Be careful these edges do not cut your skin when handling adapter boards.

## Product safety

To prevent material damage, read the following to understand risks in using adapter boards.

### Embedded systems

Setup and operation of Alvim CSI-2 cameras in embedded systems is different than for cameras in PC-based systems. Components can easily be damaged. If you are unfamiliar with embedded systems, be extremely careful. Follow the instructions in the Alvim CSI-2 Cameras User Guide.

### Electrical connections

The MIPI CSI-2 standard does not specify electrical connections as extensively as the USB or GigE standard. Read specifications carefully.

Alvim CSI-2 cameras are not protected against damage caused by reverse polarity.

## Electrostatic discharge (ESD)

Electrostatic discharge (ESD) is dangerous for electronic devices, especially when tools or hands get in contact with connectors. We recommend measures to avoid damage by ESD:

- **Unpacking:** Remove the adapter board from its anti-static packaging only when your body is grounded.
- **Workplace:** Use a static-safe workplace with static-dissipative mat and air ionization.
- **Wrist strap:** Wear a static-dissipative wrist strap to ground your body.
- **Clothing:** Wear ESD-protective clothing. Keep components away from your body and clothing. Even if you are wearing a wrist strap, your body is grounded but your clothes are not.
- **Housing:** use an ESD protective housing, including the camera, embedded board, adapter board, and FPC cable.

## Camera power

Operating cameras beyond the specified range damages cameras. Cameras are powered using the FPC connector at a maximum input of 5.5 VDC, using a limited power source (LPS), according to IEC62368-1: 2014 (Second Edition) with minimum 1.5 A per camera. Cameras are not intended to be connected to DC distribution networks.

We recommend you to power cameras with USB 2.0 Micro B power supplies providing 4.5 to 5.5 VDC at 1.5 A for 1 camera and 3.0 A for 2 cameras. Depending on the camera model and the intensity of use of the camera by your application, the power consumption may be lower.

If you want to power the camera via the embedded board, note:  
Only Jetson TX2 boards enable to power cameras, Jetson Xavier boards do not.

## FPC connectors

Hirose FH55-22S-0.5SH FPC connectors enable compact camera design. The small-sized connectors are sensitive to mechanical stress and are specified for maximum 20 mating and unmating cycles. Especially if you are inexperienced with this connector, be very cautious. If the FPC connector is broken, the complete device must be replaced. Follow the instructions in [Using the adapter board](#) on page 36 carefully.

- Avoid stress to FPC connectors.
- Allow only the FPC cable to touch conductors.

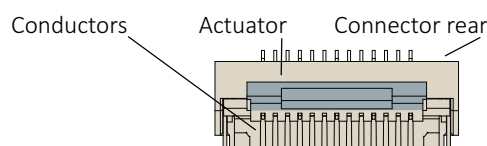

Figure 1: Hirose FH55-22S-0.5SH FPC connector



### Additional information

For technical data and more instructions on the Hirose FH55-22S-0.5SH connector, see the manufacturer data sheet at [www.hirose.com](http://www.hirose.com).

### Handling the actuator

- Move the actuator only between 0° (locked position) to 105° (open position).
- Carefully flip the actuator at the middle with your finger nail, see [Connecting FPC cables to Hirose FPC connectors](#) on page 37.

## MIPI CSI-2 FPC cables



### Manufacturing FPC cables or embedded boards

If you want to design your own components to connect Alvium CSI-2 cameras to embedded boards, contact your Allied Vision Sales representative or visit [www.alliedvision.com/en/about-us/contact-us/technical-support-repair/-rma](http://www.alliedvision.com/en/about-us/contact-us/technical-support-repair/-rma).

### FPC cable position

Short circuits of the FPC cable can damage the camera or connected hardware.

- Insert the FPC cable into the connector with cable guiding tabs matching the connector's side guides. See [Connecting FPC cables to Hirose FPC connectors](#) on page 37.
- Connect the camera and the embedded board (adapter) only as shown by the arrow printed on the FPC cable, see [Connecting FPC cables to Hirose FPC connectors](#) on page 37.

### FPC cables and stress

Over-stressed FPC cables can damage the camera and connected hardware. When camera and embedded board are twisted against each other or pulled apart from each other with too much force, the FPC cable is over-stressed. Spring contacts of FPC connectors are worn out, causing short circuits and unreliable electrical connections.

- Insert the FPC cable into the FPC connector at 12° to the PCB board surface. See [Connecting FPC cables to Hirose FPC connectors](#) on page 37.
- Allow only slight bending of the FPC cable (minimum bending radius: 10 mm).
- For strain relief, we recommend you to mount the embedded board, adapter board, and camera to a common base.

**No hot-plugging for MIPI CSI-2**

Alvium CSI-2 cameras do not support hot-plugging. Hot-plugging can destroy the camera and connected hardware by high inrush current.

- Disconnect power supplies before connecting FPC cables.

**FPC cable signal quality**

Noise and electromagnetic interference can disable camera functions.

- Avoid contact to metal surfaces, causing electromagnetic interference.
- Please use cables recommended by Allied Vision.

# Specifications



This chapter includes:

|                                 |    |
|---------------------------------|----|
| General specifications .....    | 31 |
| Dimensions and PCB layout ..... | 32 |
| Electronic schematics .....     | 33 |
| Camera power .....              | 35 |
| I/O connections .....           | 35 |

## General specifications

| Feature                                     | Specification   |
|---|---|
| Product code                                | 14909   |
| PCB number                                  | 14375 (see <a href="#">PCB and PCBA number</a> below)   |
| PCBA number                                 | 14376 (see <a href="#">PCB and PCBA number</a> below)   |
| Dimensions (Length × width × height [mm])   | 75.6 × 25 × 15.3  |
| Mass (adapter board only)                   | 10 g  |
| Storage temperature                         | -20 °C to +85 °C (ambient)  |
| Operating temperature                       | -20 °C to +65 °C (ambient)  |
| Relative humidity                           | 0% to 80% (non-condensing)  |
| Supported embedded boards                   | <ul style="list-style-type: none"> <li>NVIDIA Jetson AGX Xavier Developer Kit</li> <li>NVIDIA Jetson TX2 Developer Kit</li> </ul> |
| Supported cameras                           | Alvium CSI-2 cameras  |
| Supported FPC cables for camera connections | Allied Vision 12316, 12317, 12318, 18947  |

Table 4: Adapter for Jetson AGX Xavier and TX2 specifications

## PCB and PCBA number

The PCB number is printed to the FPC connector side, the PCBA number is placed anywhere on the circuit board, for example, like this:

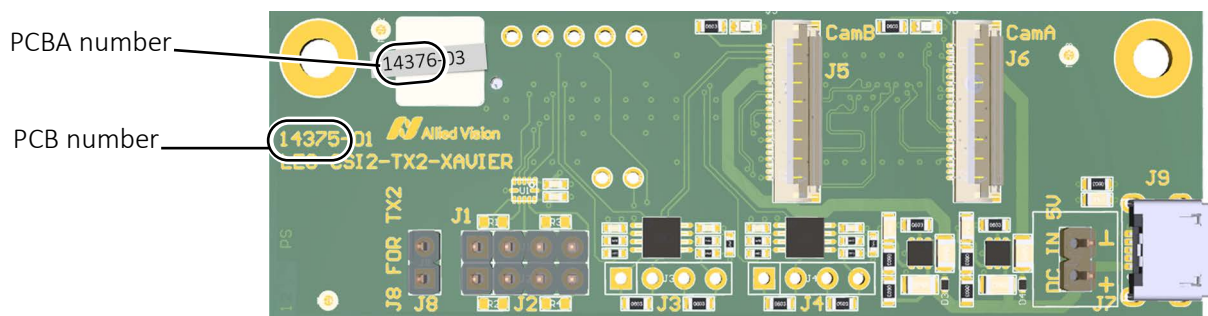

Figure 2: PCB and PCBA number on the adapter board

# Dimensions and PCB layout

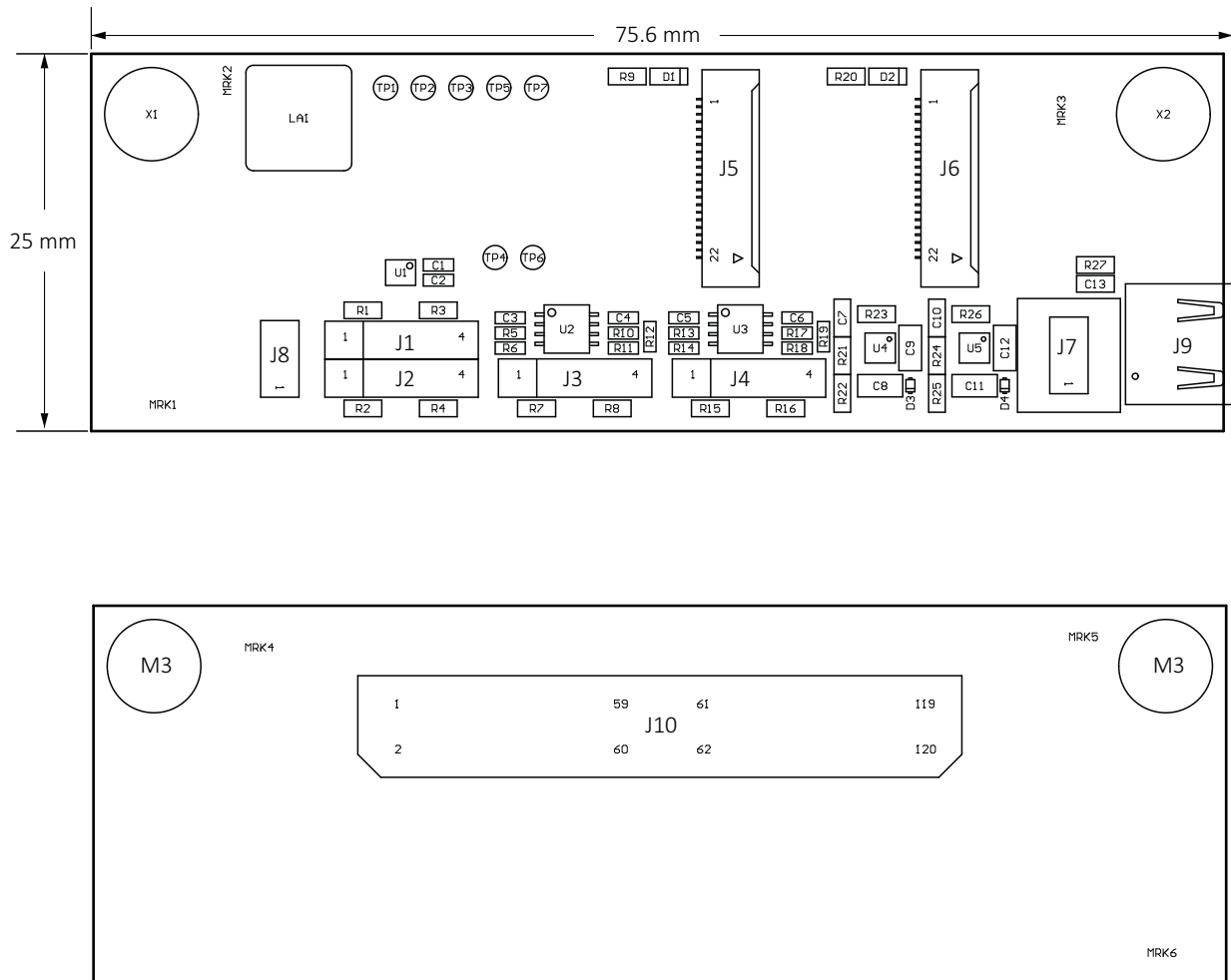
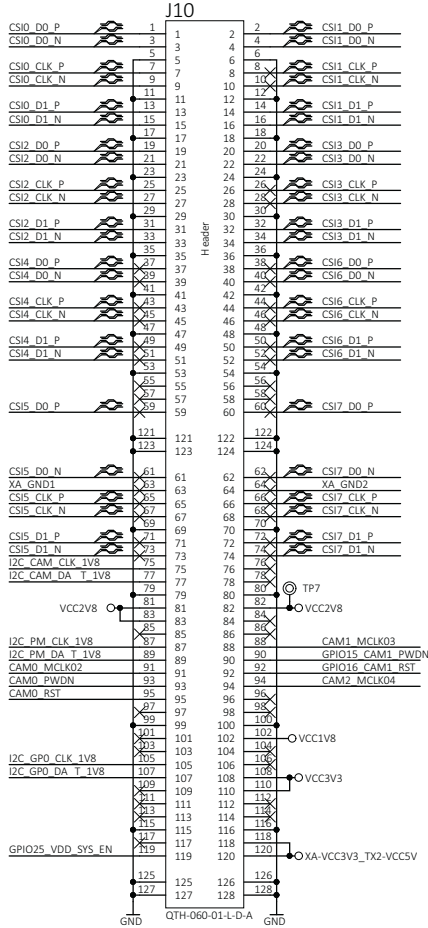
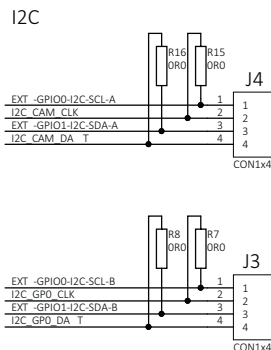

Figure 3: Adapter for Jetson AGX Xavier and TX2 dimensions and PCB layout



# Electronic schematics

To Jetson TX2 and Xavier

**Note:** J3 to J4 are not equipped.

To Alvim cameras



**Note:** R1 to R4 are not equipped.

Figure 4: Adapter for Jetson AGX Xavier and TX2 electronic schematics, part 1

VCC-EXT-IN: DCIN 4V5..5V5, max. 2 x 1.5 A

**Note:**  
J7 is not equipped.

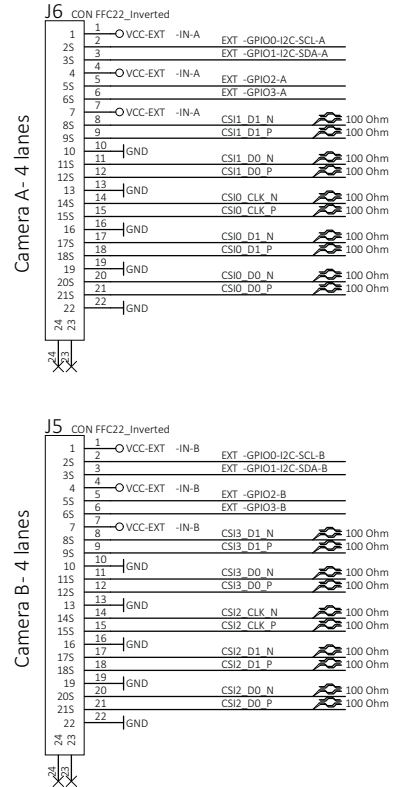
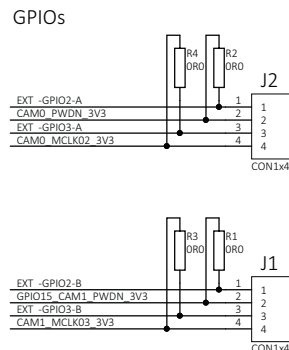
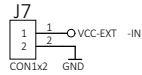
External power



**Note:**  
Recommended to be used

External USB power

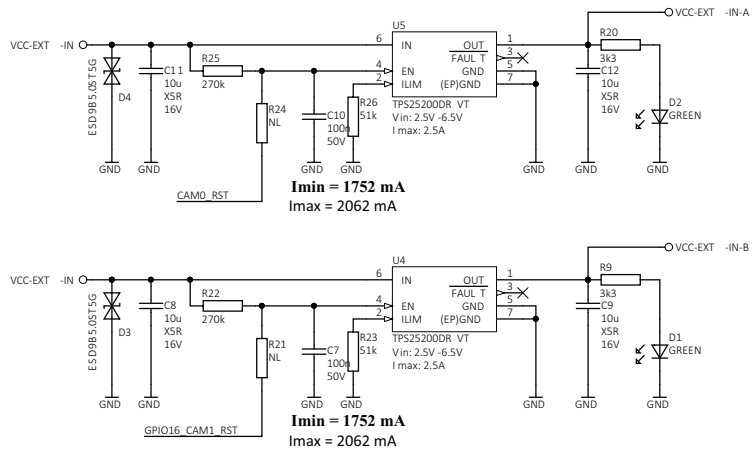
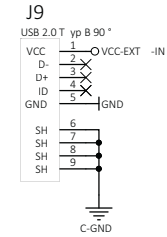

## NOTICE

### Damage to the embedded board

- We recommend you to power Alvim cameras using the USB connector J9.
- If you want to use J8 to power Alvim cameras via Jetson TX2, ensure the embedded board's power supply provides sufficient current for the Jetson TX2 board **and** the connected camera(s).
- **Do not use J8 for camera power with other embedded boards.**

Place a jumper on J8 to power Alvim cameras via Jetson TX2 boards.

TX2 power

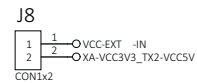

### GPIO Levelshifter 1V8 <-> 3V3

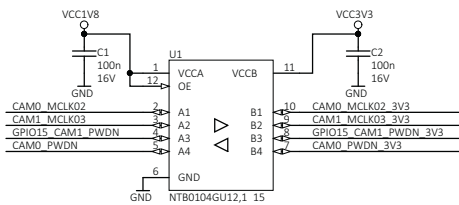

### I2C Levelshifter CAM

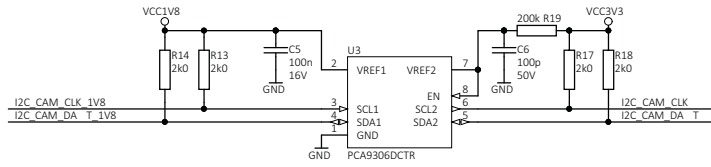

### I2C Levelshifter GPO

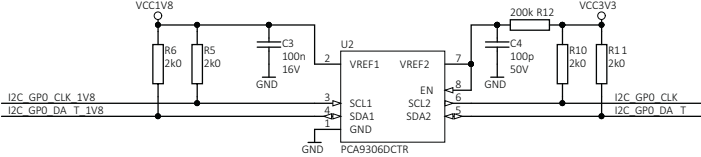

### GND <-> Chassis-GND

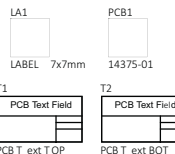
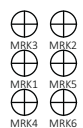
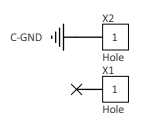
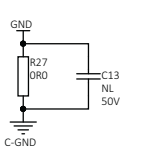

### Unused GPIO 1V8

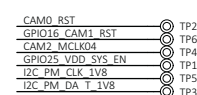

Holes on NVIDIA carrier boards are connected to GND.

Figure 5: Adapter for Jetson AGX Xavier and TX2 electronic schematics, part 2

## Camera power



### NOTICE

#### Damage to power supplies

If power supplies do not provide sufficient current, they may be damaged.

Ensure USB power supplies provide 1.5 A for 1 camera and 3.0 A for 2 cameras. Depending on the camera model and the intensity of use of the camera by your application, the power consumption may be lower.

Power Alvium cameras using the USB 2.0 Micro B receptacle (J9). See the description in [Figure 5, Adapter for Jetson AGX Xavier and TX2 electronic schematics, part 2](#) on page 34.

## I/O connections

You can use the I/O lines to trigger the camera or to output a signal from the camera to trigger a device, such as a strobe light to control illumination. Camera I/Os can be connected to the embedded board I/Os through the adapter board's pin headers. See [Table 5](#) on page 43 for details.

If you want to reduce signal latencies, such as for triggering the camera by a light barrier, you can connect I/O cables directly to the adapter board. Please see the instructions in [Connecting the I/Os](#) on page 41.

# Using the adapter board



This chapter includes:

|  |    |
|--|----|
| Embedded system accessories .....                    | 37 |
| Connecting FPC cables to Hirose FPC connectors ..... | 37 |
| Installing adapter boards .....                      | 39 |

## Embedded system accessories



### FPC cables

For more information, see the Alvium Cameras Accessory Guide at [www.alliedvision.com/en/support/technical-documentation/alvium-csi-2-documentation](http://www.alliedvision.com/en/support/technical-documentation/alvium-csi-2-documentation).



### Designing your own embedded components

If you want to design your own components to connect Alvium CSI-2 cameras to embedded boards, contact your Allied Vision Sales representative or visit [www.alliedvision.com/en/about-us/contact-us/technical-support-repair/-rma](http://www.alliedvision.com/en/about-us/contact-us/technical-support-repair/-rma).

Proper usage of the Hirose FH55-22S-0.5SH FPC connector is vital for connecting Alvium CSI-2 cameras to embedded boards. Therefore, instructions start with usage of the FPC connector. Afterwards, setting up the adapter boards is described.

## Connecting FPC cables to Hirose FPC connectors

Figure 6 shows how the FPC cable connects to the FPC connector.

Follow the instructions to connect the FPC cable to the camera and to the embedded board.

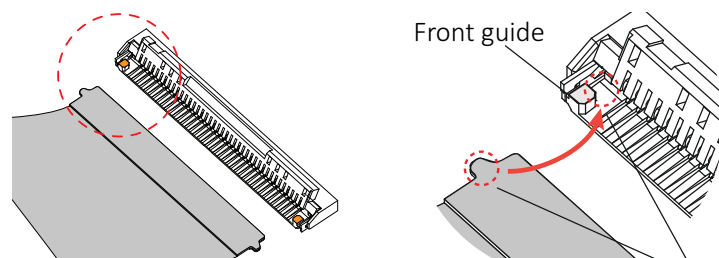

Figure 6: FPC cable and FPC connector (open position)

1. Opening the FPC connector:  
With your fingernail\*, flip the actuator to open position at 105° to the PCB surface, see Figure 7.

\*Or use a plastic tool, as metal tools can damage the actuator.

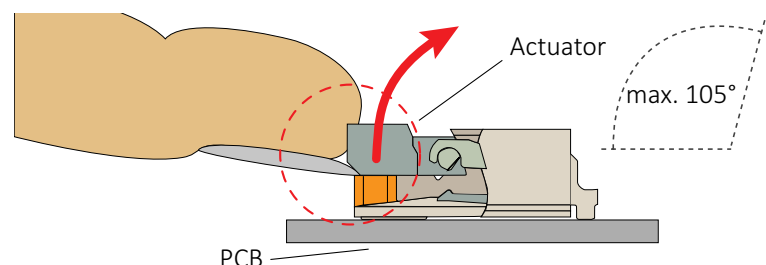

Figure 7: Opening the FPC connector

**NOTICE**
**Damage to the camera by reverse polarity**

If Alvium CSI-2 cameras are powered with reverse polarity, camera electronics is damaged.

- Before connecting camera power and I/O power, carefully read the Alvium Cameras User Guide for the FPC connector pin assignment.
- Connect the cable as shown in this section.

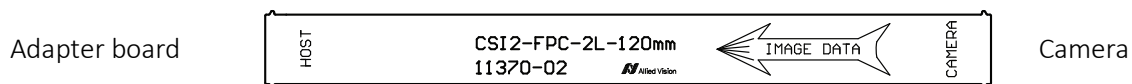

Figure 8: FPC cable image data direction

2. **Ensuring proper cable direction between host and camera**, take the FPC cable with conductors facing the FPC connector conductors (see Figure 9).

3. Inserting the FPC cable:  
At a horizontal angle of  $90^\circ$  to the connector's rear (see Figure 9) and at a vertical angle of  $12^\circ$  to the PCB (see Figure 10), slowly insert the FPC cable into the actuator...

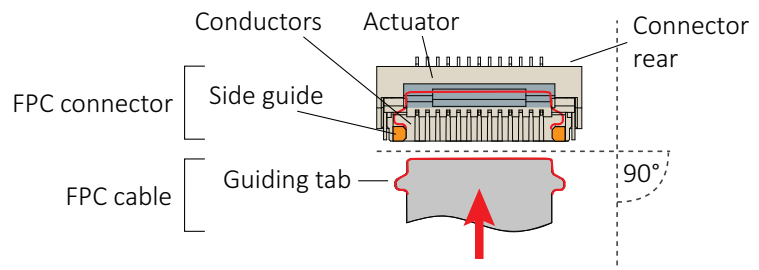

Figure 9: FPC cable and FPC connector

4. ...until cable guiding tabs are caught between connector rear and side guides (see Figure 9). Pull the cable slightly to ensure guiding tabs are properly engaged.
5. Holding the FPC cable in position, flap down the actuator to closed position (see Figure 10).

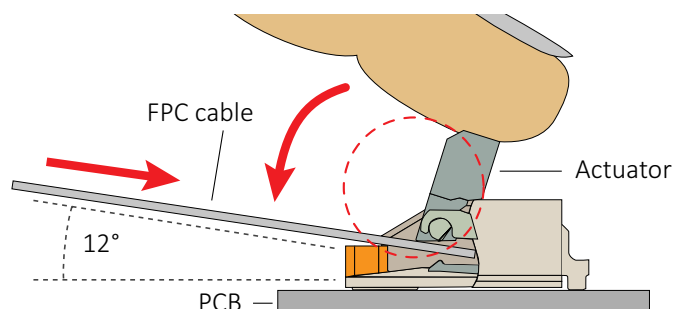

Figure 10: Engaging the FPC cable in the FPC connector

# Installing adapter boards



## CAUTION

### Burns to the skin

Electrical components get hot during operation.

- Before operation, include adapter boards in housings that disable any contact to hot components.



## NOTICE

### Damage to electronics

- Disconnect all power supplies before installing the adapter board to your embedded board.
- Reconnect power only after installation is complete.
- Mount the embedded board, adapter board, and camera on a common base for strain relief.



### NVIDIA Jetson Manuals

For details on NVIDIA Jetson Nano boards, including FFC connectors, see the manufacturer's manual at

[www.nvidia.com/en-us/autonomous-machines/embedded-systems](http://www.nvidia.com/en-us/autonomous-machines/embedded-systems).

## Connecting the embedded board

1. Connect the embedded board connector (a) of the adapter board to the camera connector of the embedded board.

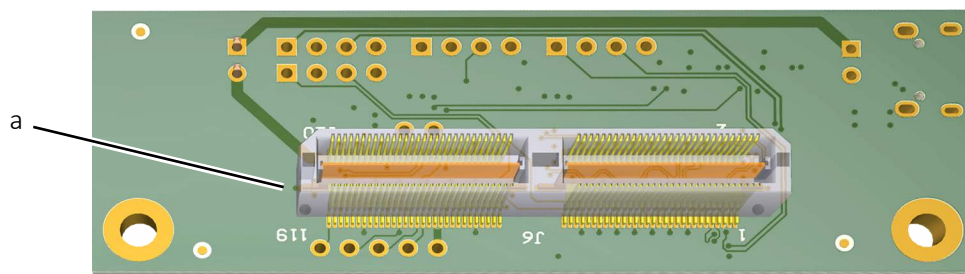

Figure 11: Embedded board connector of the adapter board (bottom view)

## Connecting the camera



### FPC camera connector priority

The FPC camera connectors J5 and J6 have the same priority.

1. Following the instructions in [Connecting FPC cables to Hirose FPC connectors](#) on page 37, connect the FPC cable to one of the FPC camera connectors (b).
2. Connect the other end of the FPC cable to the camera.

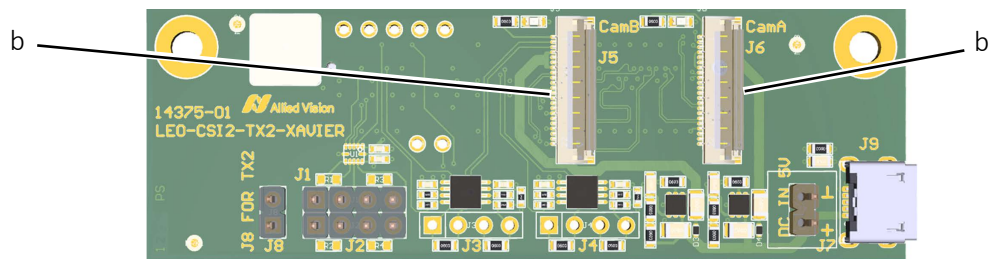

Figure 12: FPC camera connectors of the adapter board (top view)

Your Alvim CSI-2 camera is connected to the embedded board.

## Connecting USB power

We recommend you to power the camera(s) using USB power.



### NOTICE

#### Damage to power supplies

If power supplies do not provide sufficient current, they may be damaged.

Ensure USB power supplies provide 1.5 A for 1 camera and 3.0 A for 2 cameras. Depending on the camera model and the intensity of use of the camera by your application, the power consumption may be lower.

1. Ensure the USB power supply is disconnected from the mains power.
2. Connect the power supply's output connector to the USB 2.0 Micro B receptacle (c).

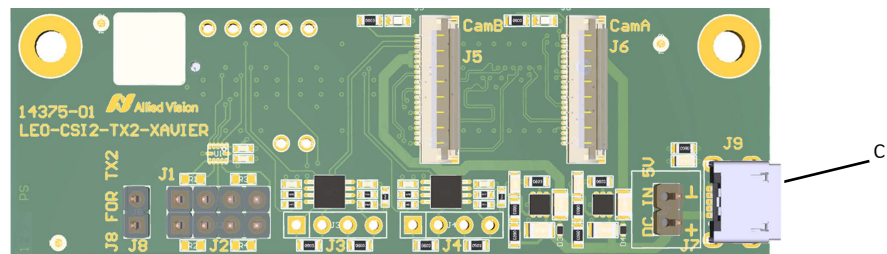

Figure 13: FPC camera connectors of the adapter board

3. Connect the power supply to the mains power.
4. Power and boot the embedded board.

Your Alvim CSI-2 cameras can be operated via the embedded board.



## Connecting the I/Os

If you want to use the I/O lines of the **adapter board**, see the following instruction. This way, you reduce signal latencies, such as for triggering the camera by a light barrier



### About this instruction

This is a best-practice solution. Please visit [www.alliedvision.com/en/about-us/contact-us/technical-support-repair-/rma](http://www.alliedvision.com/en/about-us/contact-us/technical-support-repair-/rma) if you have any questions.

### Camera A

Camera A is connected to the embedded board by FPC connector J6 (d).

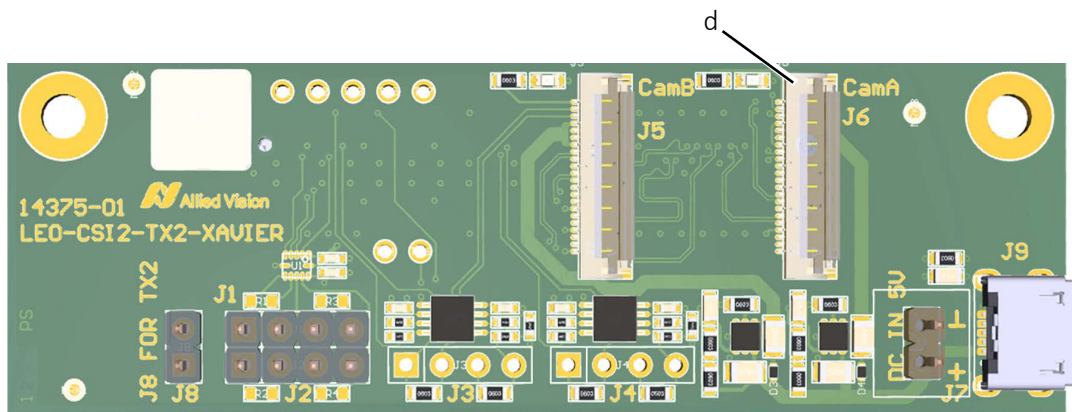

Figure 14: Camera A connection

1. On the pin header (e) on connector J2, use the I/O pins defined in [I/O signal levels and description](#) on page 43.

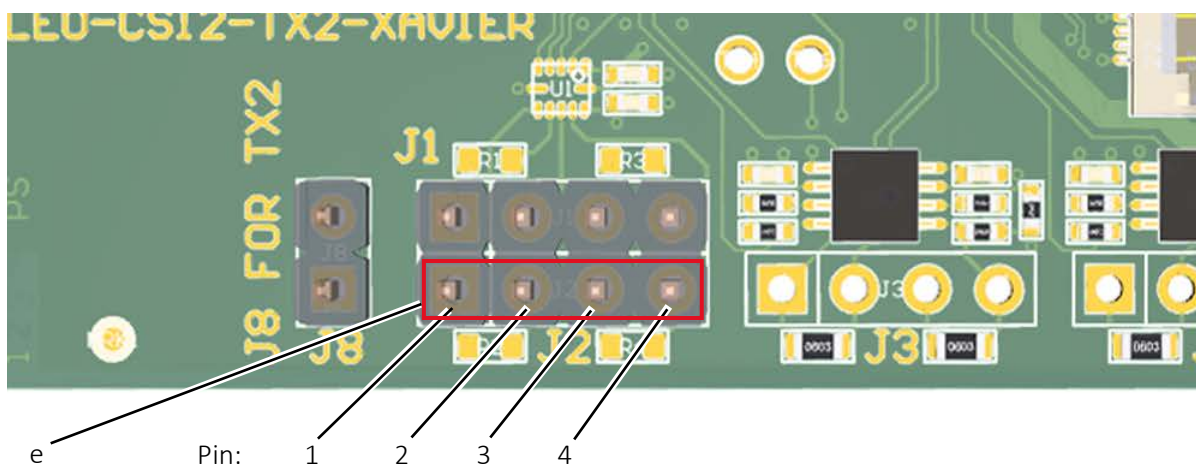

Figure 15: Connecting the I/Os for Camera A

2. For connecting ground, continue with [Connecting ground](#) on page 42.

## Camera B

Camera B is connected to the embedded board by FPC connector J5 (f).

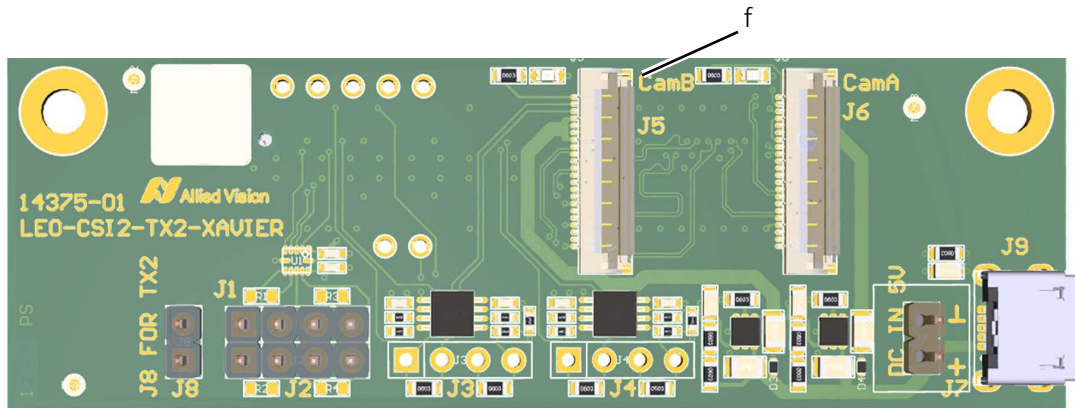

Figure 16: Camera B connection

3. On the pin header (g) on connector J1, use the I/O pins defined in [I/O signal levels and description](#) on page 43.

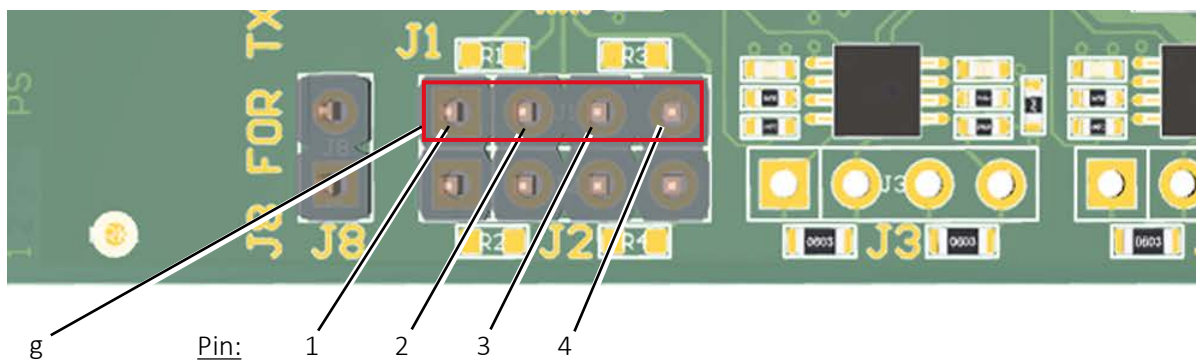

Figure 17: Connecting the I/Os for Camera B

## Connecting ground

4. Connect GND to pin 2 (h) of connector J7.

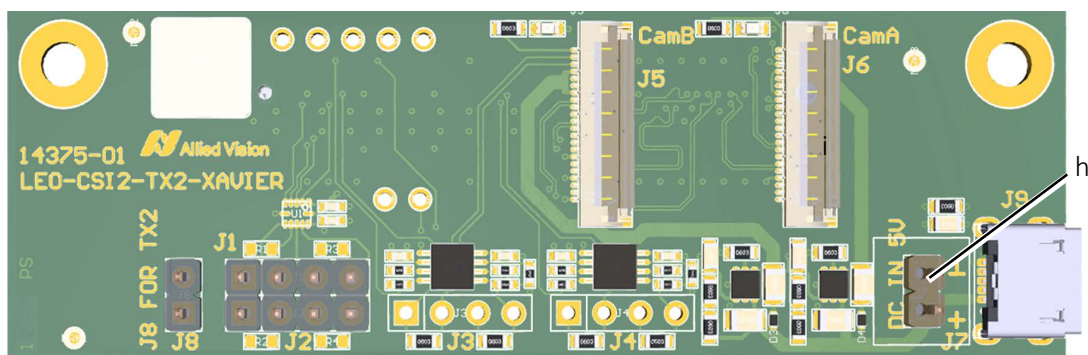

Figure 18: Connecting GND

## I/O signal levels and description

Table 5 displays the signals for the GPIOs on connectors J1 and J2, for GND on connector J7, and for VCC-EXT-IN on the USB connector J9.

| Connector | Pin | Signal           | < - >  | Level   | Description   |
|-----------|-----|------------------|--------|---|---|
| J1        | 1   | EXT-GPIO2-B      | IN/OUT | $U_{in} (low) = -0.3 \text{ to } 0.8 \text{ VDC}$<br>$U_{in} (high) = 2.0 \text{ to } 5.5 \text{ VDC}$<br>$U_{out} (low) = 0 \text{ to } 0.4 \text{ VDC}$<br>$U_{out} (high) = 2.4 \text{ to } 3.3 \text{ VDC}$<br>at max. 12 mA    | GPIO<br>Internal pull-up resistor:<br>33 k $\Omega$ to 63 k $\Omega$          |
| J1        | 2   | GPIO15_CAM1_PWDN | IN/OUT | $U_{in} (low)^1 = 0 \text{ to } 1.2 \text{ VDC}$<br>$U_{in} (high)^1 = 2.2 \text{ to } 5.5 \text{ VDC}$<br>$U_{out} (low) = 0 \text{ to } 0.4 \text{ VDC}$<br>$U_{out} (high)^1 = 2.9 \text{ to } 3.3 \text{ VDC}$<br>at max. 50 mA | GPIO<br>Keep external pull-up or<br>pull-down resistor above<br>50 k $\Omega$ |
| J1        | 3   | EXT-GPIO3-B      |        | See EXT-GPIO2-B   |   |
| J1        | 4   | CAM1_MCLK03      |        | See GPIO15_Cam1_PWDN  |   |
| J2        | 1   | EXT-GPIO2-A      |        | See EXT-GPIO2-B on connector J1   |   |
| J2        | 2   | CAM0_PWDN        |        | See GPIO15_CAM1_PWDN on connector J1  |   |
| J2        | 3   | EXT-GPIO3-A      |        | See EXT-GPIO2-B on connector J1   |   |
| J2        | 4   | CAM0_MCLK02      |        | See CAM1_MCLK03 on connector J1   |   |
| J7        | 1   | VCC-EXT-IN       | PWR IN | 4.5 to 5.5 VDC  | Power supply  |
| J7        | 2   | GND              | PWR    | 0 VDC   | Power supply ground   |
| J9        | 1   | VCC-EXT-IN       | PWR IN | 4.5 to 5.5 VDC  | USB power supply  |

<sup>1</sup>Depends on the 3.3 VDC output voltage of the embedded board

Table 5: I/O connections from the adapter board to the camera