

## ALVIUM GMSL2 COAX CAMERAS

# Deserializer Board GMSL2 Coax to CSI-2

## User Guide

V1.0.1

**Quick links**

- [This document at a glance](#) on page 9
- [Contact us](#) on page 11
- [Contents](#) on page 12

# Read before use

## EN - English

### Safety

Before using the product, read these safety instructions. Observe the warnings at all times. Use the product only as stated in the [Intended use](#) on page 18.

**CAUTION****Risk of burns**

The product in operation can reach temperature levels which could cause burns.

### Intended use

Intended use of Allied Vision product is the integration into vision systems by professionals. All Allied Vision product is sold in a B2B setting.

## DA - Dansk

### Sikkerhed

Læs sikkerhedsanvisningerne, før produkt bruges. Overhold alle advarsler. Brug kun produkt som anført i [Intended use](#) på side 18.

**FORSIGTIG****Forbrændingsfare**

Når produkt bruges, kan det blive meget varmt og forårsage forbrændinger.

### Tilsigtet brug

Allied Vision produktets tilsigtede brug er en indbygning i et visionssystem, udført af fagfolk. Alle Allied Vision produkter sælges i B2B.

## DE - Deutsch

### Sicherheit

Bevor Sie das Produkt benutzen, lesen Sie diese Sicherheitshinweise. Beachten Sie diese Hinweise immer. Verwenden Sie das Produkt nur wie beschrieben in [Intended use](#) auf Seite 18.



#### **Gefahr von Verbrennungen**

Im Betrieb kann das Produkt Temperaturen erreichen, die zu Verbrennungen führen.

### Bestimmungsgemäßer Gebrauch

Allied Vision Produkte sind bestimmt für die Integration in Bildverarbeitungssysteme durch Fachpersonal. Alle Allied Vision Produkte werden in einer B2B-Umgebung verkauft.

## ES - Español

### Seguridad

Antes de utilizar el producto lea estas instrucciones de seguridad. Observe las advertencias en todo momento. Utilice el producto solo tal y como se estipula en el [Intended use](#) en la página 18.



#### **ATENCIÓN**

#### **Riesgo de quemaduras**

El producto en funcionamiento puede alcanzar temperaturas que podrían provocar quemaduras.

### Uso previsto

El uso previsto del producto Allied Vision es la integración en el sistema de visión por parte de profesionales. Todos los productos Allied Vision se venden dentro de una relación B2B.

## FI - Suomi

### Turvallisuus

Lue nämä turvallisuusohjeet ennen tuotteen käyttöä. Noudata tuotetta joka hetki. Käytä tuotteen ainoastaan kohdassa [Intended use](#) sivulla 18 kuvatulla tavalla.



#### HUOMIO

##### Palovammojen vaara

Käytössä olevan tuotteen saavuttamat lämpötilatasot voivat aiheuttaa palovammoja.

### Käyttötarkoitus

Allied Vision-tuotteen käyttötarkoitus on integrointi kuvajärjestelmiin ammattilaisten toimesta. Kaikki Allied Vision-tuotteet myydään B2B-ympäristössä.

## FR - Français

### Sécurité

Veillez lire ces consignes de sécurité avant d'utiliser le produit. Respectez continuellement les avertissements. Utilisez le produit uniquement comme indiqué sous [Intended use](#), page 18.



#### ATTENTION

##### Risque de brûlures

Le produit en service peut atteindre des niveaux de température susceptibles d'entraîner des brûlures.

### Utilisation prévue

L'utilisation prévue du produit Allied Vision est son intégration dans des systèmes de vision par le soin de professionnels. Tout produit Allied Vision est vendu dans un cadre B2B.

## עברית - HE

### בטיחות

לפני השימוש במוצר, עליך לקרוא את הוראות הביטחון האלו. עליך לממש הוראות ביטחון אלו תמיד. השימוש במצלמה הוא רק לפי מה שכתוב ב"כוונת השימוש" (*Intended use* בעמוד 18).

#### זהירות

#### סכנת כווייה

בזמן הפעלת המוצר עלולות לעלות טמפרטורות גבוהות, שיכולות לגרום לכוויות.



### שימוש מיועד

מוצרי AlliedVision מיועדים לשילוב במערכות ממוחשבת לעיבוד צילומים ע"י אנשי מקצוע. כל מוצרי AlliedVision נמכרים לשימוש בסביבת B2B.

## IT - Italiano

### Sicurezza

Leggere queste istruzioni per la sicurezza prima di utilizzare il prodotto. Osservare sempre tutte le avvertenze. Utilizzare il prodotto come descritto alla sezione [Intended use](#) a pagina 18.



#### ATTENZIONE

#### Pericolo di ustioni

Durante il funzionamento, il prodotto può raggiungere temperature elevate che possono essere causa di ustioni.

### Uso previsto

Il prodotto Allied Vision è concepito per essere integrato in sistemi di monitoraggio in campo professionale. Tutti i prodotti Allied Vision sono venduti in uno scenario B2B.

## JA - 日本語

### 安全性

本製品を使用する前に、この安全ガイドをお読みください。警告を必ず守ってください。必ず21ページのIntended use 18 ページに従って使用してください。



#### 注意

##### やけどの危険性

作動中のカメラは、やけどを引き起こす温度まで熱くなる恐れがあります。

### 用途

Allied Vision製品は、専門家が視覚装置に統合することを意図したものです。すべてのAllied Vision製品は、企業間取り引き用に販売されています。

## NL - Nederlands

### Veiligheid

Lees deze veiligheidsinstructies voordat u het product gebruikt. Neem deze waarschuwingen altijd in acht. Gebruik het product uitsluitend, zoals aangegeven in het Intended use op pagina 18.



#### VOORZICHTIG

##### Risico van verbranding

Het gebruikte product, kan temperatuurwaarden bereiken die brandwonden kunnen veroorzaken.

### Beoogd gebruik

Het beoogde gebruik van het Allied Vision-product is de integratie in optische systemen door professionals. Alle Allied Vision-producten worden verkocht in de B2B-markt.

## NO - Norsk

### Sikkerhet

Les disse sikkerhetsinstruksene før du bruker produkt. Følg advarslene til en hver tid. Bruk kun produkt i samsvar med [Intended use](#) på side 18.



#### FORSIKTIG

##### Risiko for brannskader

Produktet i bruk kan nå temperaturnivåer som kan forårsake brannskader.

### Tiltenkt bruk

Den tiltenkte bruken av Allied Vision-produktet er integrering i visjonssystemer av profesjonelle. Alle Allied Vision-produkter selges i en forretning til forretning-situasjon.

## SV - Svenska

### Säkerhet

Läs igenom säkerhetsinstruktionerna innan du använder produkten. Var hela tiden särskilt uppmärksam på varningarna. Använd enbart produkten på det sätt som anges i [Intended use](#) på sida 18.



#### VARNING

##### Risk för brännskada

Produkten i drift kan komma upp i temperaturer som kan orsaka brännskador.

### Avsedd användning

Den avsedda användningen av Allied Vision-produkter är integrering i visionssystem av fackmän. Samtliga Allied Vision-produkter säljs i en B2B-miljö.

## ZH - 简体中文版

### 安全需知

在使用产品之前，请阅读这些安全说明。请务必遵守相关警告和 [Intended use](#) 于第 18 页。



### 注意事项

#### 烫伤风险

在产品运行过程中，温度可能会上升，导致烧伤的危险。

### 预期用途

Allied Vision 产品的预期用途是由专业人士整合到视觉系统中。所有 Allied Vision 的产品均通过 B2B 渠道销售。



# This document at a glance



Get an overview of documentation for the Deserializer Board  
GMSL2 Coax to CSI-2:

Note.....	10
Shipping contents.....	10
What else do you need? .....	10

## Note



### Read this document carefully

Learn to use deserializer boards in the most safe and efficient way and avoid damage to your embedded system.

## Shipping contents

The delivery consists of

- Deserializer Board GMSL2 Coax to CSI-2
- 4 preassembled jumpers for 5 VDC over FPC connector (default power mode) for Channel A and Channel B
- 2 jumpers to disable internal step up converter for 24 VDC.



### Input power settings

See [Connecting power](#) on page 34 for jumpers and connections.



### Cables are not included

MIPI CSI-2 FPC cables to connect to the host and to the deserializer board and FAKRA coaxial cables to connect the deserializer board to Alvium FP3/GM2 Coax cameras are not included.

## What else do you need?

This is a selection of helpful downloads:

Download	Link
<b>Camera documentation</b> for installation and operation: <ul style="list-style-type: none"> <li>• Alvium FP3/GM2 User Guide</li> <li>• Alvium CSI-2 Cameras User Guide</li> </ul>	<a href="http://www.alliedvision.com/en/support/technical-documentation/alvium-csi-2-documentation/">www.alliedvision.com/en/support/technical-documentation/alvium-csi-2-documentation/</a>
<b>Accessories</b> , such as FAKRA coaxial cables, FPC cables, I/O cables, lenses, and tripod adapters	<a href="http://www.alliedvision.com/en/products/accessories">www.alliedvision.com/en/products/accessories</a>
<b>SerDes Configurator:</b> Please contact the Allied Vision Support team at...	<a href="http://www.alliedvision.com/en/about-us/contact-us/technical-support-repair-/-rma">www.alliedvision.com/en/about-us/contact-us/technical-support-repair-/-rma</a>

Table 1: Downloads for Deserializer Board GMSL2 Coax to CSI-2

# Contact us

## Website, email

### General

[www.alliedvision.com/en/contact](http://www.alliedvision.com/en/contact)  
[info@alliedvision.com](mailto:info@alliedvision.com)

### Distribution partners

[www.alliedvision.com/en/avt-locations/avt-distributors](http://www.alliedvision.com/en/avt-locations/avt-distributors)

### Support

[www.alliedvision.com/en/support](http://www.alliedvision.com/en/support)  
[www.alliedvision.com/en/about-us/contact-us/technical-support-repair/-/rma](http://www.alliedvision.com/en/about-us/contact-us/technical-support-repair/-/rma)

## Offices

### Europe, Middle East, and Africa (Headquarters)

Allied Vision Technologies GmbH  
Taschenweg 2a  
07646 Stadtroda, Germany  
T// +49 36428 677-0 (Reception)  
T// +49 36428 677-230 (Sales)  
F// +49 36428 677-28

### Asia-Pacific

#### China

Allied Vision Technologies  
(Shanghai) Co., Ltd.  
2-2109 Hongwell Int. Plaza  
1602# ZhongShanXi Road  
Shanghai 200235, China  
T// +86 21 64861133

#### Singapore

Allied Vision Technologies Asia Pte. Ltd  
82 Playfair Rd, #07-01 D'Lithium  
Singapore 368001  
T// +65 6634 9027

### North, Central, and South America

#### Canada

Allied Vision Technologies Canada Inc.  
300 – 4621 Canada Way  
Burnaby, BC V5G 4X8, Canada  
T// +1 604 875 8855

#### USA

Allied Vision Technologies, Inc.  
102 Pickering Way- Suite 502  
Exton, PA 19341, USA  
Toll-free// +1-877-USA-1394  
T// +1 978 225 2030

# Contents

Read before use .....	2
This document at a glance .....	9
Note .....	10
Shipping contents .....	10
What else do you need? .....	10
Contact us .....	11
Document history and conventions .....	14
Document history .....	15
Conventions used in this user guide .....	15
Typographical styles .....	15
Symbols and notes .....	15
Component naming .....	16
Compliance, safety, and intended use .....	17
Compliance notifications .....	18
Intended use .....	18
Copyright and trademarks .....	18
Your safety .....	19
Handling hot deserializer boards .....	19
Product safety .....	19
ESD .....	19
Electrical connections .....	19
Specifications .....	23
Specifications overview .....	24
PCB and PCBA number .....	25
Technical drawing .....	25
Electronic schematics .....	26
Setting up deserializer boards .....	28
Connecting FAKRA coaxial cables .....	29
FAKRA coaxial cable-side connectors .....	29
Instructions for connecting .....	30
Instructions for disconnecting .....	30
Connecting FPC cables .....	31

Mounting deserializer boards .....	33
Connecting components to each other.....	33
Connecting power .....	34

# Document history and conventions



This chapter includes:

Document history .....	15
Conventions used in this user guide.....	15
Component naming .....	16

## Document history

Version	Date	Remarks
V1.0.1	2023-Aug-02	<ul style="list-style-type: none"> <li>Changes in <a href="#">Specifications</a> on page 23:                             <ul style="list-style-type: none"> <li>- Added 18947 FPC cable.</li> <li>- Updated dimension values and drawings to include connectors.</li> </ul> </li> <li>Applied editorial changes.</li> </ul>
V1.0.0	2023-Apr-27	Release version

Table 2: Document history

## Conventions used in this user guide

To give this user guide an easily understood layout and to emphasize important information, the following typographical styles and symbols are used:

### Typographical styles

Style	Function
<b>Emphasis</b>	Highlighting important things
<a href="#">Web links and references</a>	Links to webpages and internal cross references

Table 3: Typographical styles

### Symbols and notes



#### CAUTION

##### Risk of burns

Precautions are described



#### NOTICE

##### Material damage

Precautions are described.



##### Practical tip

Additional information helps to understand or ease handling the camera and components.

**Additional information**

Web link or reference to an external source with more information is shown.

## Component naming

Components described in this user guide are not defined by common standards. Therefore, naming must be accurate to avoid misconceptions. Simplified terms are used in this document to avoid lengthy naming.

Short version used in this document	Long version
Adapter board	Example: Adapter Board for Auvideo JNX30 SoM (adapts Alvium CSI-2 cameras and deserializer boards to Auvideo JNX30 embedded boards)
Deserializer board	Deserializer Board GMSL2 Coax to CSI-2
Embedded board	Example: Auvideo JNX30 SoM (system on module)
FPC connector	Hirose FH55-22S-0.55SH FPC (flexible printed circuit) connector
FPC cable	MIPI CSI-2 FPC cable

*Table 4: Component naming*



# Compliance, safety, and intended use



This chapter includes:

Compliance notifications .....	18
Intended use .....	18
Copyright and trademarks .....	18
Your safety.....	19
Product safety .....	19

## Compliance notifications

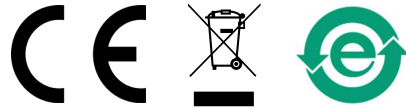

National regulations on disposal must be followed.

## Intended use

Allied Vision's objective is the development, design, production, maintenance, servicing and distribution of digital cameras and components for image processing. We are offering standard products as well as customized solutions.

Intended use of Allied Vision product is the integration into Vision systems by professionals. All Allied Vision product is sold in a B2B setting.

Allied Vision isn't a legal manufacturer of medical product. Instead, Allied Vision cameras and accessories may be used as components for medical product after design-in by the medical device manufacturer and based on a quality assurance agreement (QAA) between Allied Vision (supplier) and medical device manufacturer (customer). Allied Vision's duties in that respect are defined by ISO 13485, clause 7.2 (customer-related processes, equivalent to ISO 9001, clause 8.2).

## Copyright and trademarks

All text, pictures, and graphics are protected by copyright and other laws protecting intellectual property. All content is subject to change without notice.

All trademarks, logos, and brands cited in this document are property and/or copyright material of their respective owners. Use of these trademarks, logos, and brands does not imply endorsement.

Copyright © 2023 Allied Vision Technologies GmbH. All rights reserved.

## Your safety

This section informs about issues related to your personal safety. Descriptions explain how to avoid hazards and use deserializer boards safely.

### Handling hot deserializer boards

Electrical components of deserializer boards get hot during operation.

Before operation, include deserializer boards in housings that disable any contact to hot components.

## Product safety

To prevent material damage, read the following to understand risks in using deserializer boards.

### ESD

ESD is dangerous for electronic devices, especially when tools or hands get in contact with connectors and electronic components. We recommend measures to avoid damage by ESD:

- Unpacking: Remove the deserializer board from its anti-static packaging only when your body is grounded.
- Workplace: Use a static-safe workplace with static-dissipative mat and air ionization.
- Wrist strap: Wear a static-dissipative wrist strap to ground your body.
- Clothing: Wear ESD clothing. Keep components away from your body and clothing. Even if you are wearing a wrist strap, your body is grounded but your clothes are not.

### Electrical connections

GMSL2 does not specify electrical connections as extensively as the USB or GigE standard. Plug and play is not supported. Read specifications carefully.

Components can easily be damaged. If you are unfamiliar with GMSL2 connections or with embedded systems, be extremely careful. Follow the instructions in the Alvium FP3/GM2 User Guide.

Allied Vision accessories help to avoid damage to the camera and connected components.



#### Compatible accessories

We recommend using accessories by Allied Vision, see [www.alliedvision.com/en/products/accessories](http://www.alliedvision.com/en/products/accessories).

## Strain relief for all cable connections

If FAKRA coaxial connectors are exposed to excessive stress, they can break off from devices. Hirose FH55 FPC connectors can be damaged easily.

Provide sufficient strain relief for all cable connections to avoid malfunctions and damage to electronics by wrong polarity and short circuits. To protect cameras and connected components, secure cables as shown in [Figure 1](#).

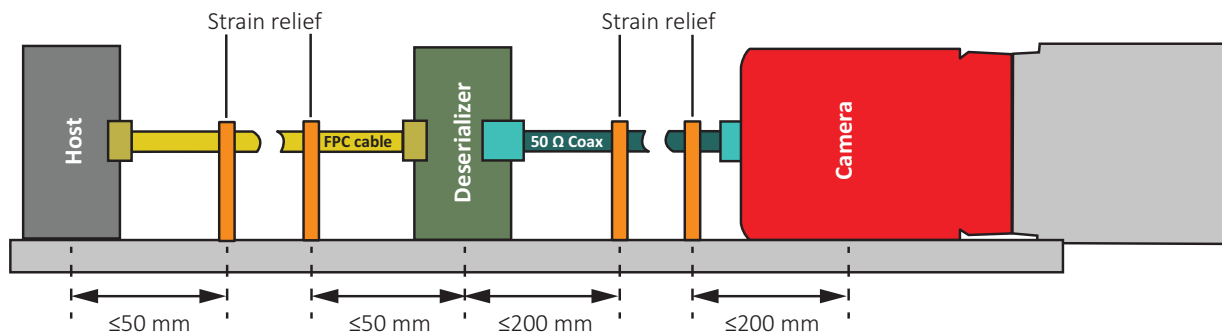

Figure 1: Strain relief for all cable connections

## FAKRA coaxial connectors and cables

FAKRA coaxial connectors enable a robust connection. However, if the cable is overstressed, these connectors can break off from devices.

- Unlock the cable connector while you are disconnecting devices.
- Avoid stress to FAKRA coaxial connectors and cables.
- Observe the minimum bending radius for coaxial cables.
- Observe instructions for [Strain relief for all cable connections](#) on page 20.
- Follow the instructions in [Connecting FAKRA coaxial cables](#) on page 29.



Figure 2: FAKRA coaxial connectors on cameras (left) and on cables (right)



### Additional information

For technical data and more instructions on the FAKRA coaxial connector Code Z (water blue), see the manufacturer data sheet at [www.rosenberger.com](http://www.rosenberger.com).

## FPC connectors

Small-sized Hirose FH55-22S-0.55SH FPC connectors enable compact board design. Therefore, they are sensitive to mechanical stress. Especially if you are inexperienced with these, be very cautious. If FPC connectors are broken, the complete device must be replaced. Follow the instructions in [Connecting FPC cables](#) on page 31 carefully.

- Avoid stress to FPC connectors.
- Allow only the FPC cable to touch conductors.

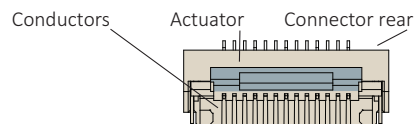

Figure 3: Hirose FH55-22S-0.55SH FPC connector

## Mating and unmating cycles

FPC connectors are designed for one-time installation, with the opportunity for corrections. Therefore, these connectors are specified for **maximum 20** mating and unmating cycles.

## Handling the actuator

- Move the actuator only as described in the instructions.
- Carefully flip the actuator at the middle with your finger nail as described in the instructions.
- Follow the instructions in [Connecting FPC cables](#) on page 31.



### Additional information

For technical data and more instructions on the Hirose connectors, see [www.hirose.com](http://www.hirose.com).

## FPC cables

### FPC cable position and orientation

Short circuits of FPC cables can damage the camera or connected hardware. Insert FPC cables into FPC connectors with cable guiding tabs matching the connector's side guides. See [Connecting FPC cables](#) on page 31.

### FPC cables and stress

Over-stressed FPC cables can damage the camera and connected hardware. When connected devices are twisted against each other or pulled apart from each other with too much force, the FPC cable is over-stressed. Spring contacts of FPC connectors are worn out, causing short circuits and unreliable electrical connections.

- Allow only slight bending of the FPC cable (minimum bending radius: 10 mm).
- For strain relief, see [Strain relief for all cable connections](#) on page 20.

## No hot-plugging for GMSL2

Alvium FP3/GM2 Coax cameras do not support hot-plugging. Hot-plugging can destroy the camera and connected hardware by high inrush current.

Disconnect power supplies before connecting or disconnecting devices from each other.

## Signal quality

Noise and electromagnetic interference can disable camera functions.

- Avoid squeezing cables and bending cables over edges.
- Avoid contact to metal surfaces, causing electromagnetic interference.
- Please use cables recommended by Allied Vision.

## Camera power

Operating cameras beyond the specified range damages cameras. Cameras are powered using the FAKRA coaxial connector, using a limited power source (LPS), according to IEC 62368-1. For maximum power input, see your camera's specifications in the Alvium FP3/GM2 User Guide. The camera is not intended to be connected to a DC distribution network.

Only use power supplies that meet the insulation requirement according to PELV or SELV. For details, please refer to IEC 61140.

## Use only power supplied via the deserializer board

Alvium FP3/GM2 Coax cameras use the same 10-pin TFM connector as Alvium G1 and G5 cameras. But the 10-pin TFM connector on Alvium FP3/GM2 Coax cameras must not be used as power input.

- Use the 10-pin TFM connector only as power output and for I/O control.
- Connect power as described in [Connecting power](#) on page 34.

## Ground loops

Unsuitable connections can lead to different potentials between the camera system GND and the environmental shield/chassis GND caused by ground loops. This can damage the camera and the connected devices or cause malfunctions.

- Avoid potential differences between the camera housing and GND.
- All wiring must be done by authorized personnel, according to the corresponding technical standards.
- You may mount the camera electrically isolated.
- Read the Avoiding Ground Loops in Vision Systems application note.



### More information

See the Avoiding Ground Loops in Vision Systems application note at [www.alliedvision.com/en/support/technical-documentation/alvium-csi-2-documentation](http://www.alliedvision.com/en/support/technical-documentation/alvium-csi-2-documentation).

# Specifications



This chapter includes:

Specifications overview.....	24
PCB and PCBA number.....	25
Technical drawing.....	25
Electronic schematics .....	26

## Specifications overview

Feature	Specification
Product code	19503
PCB number	16590 (see <a href="#">PCB and PCBA number</a> on page 25)
PCBA number	16591 (see <a href="#">PCB and PCBA number</a> on page 25)
Connector to the host	Hirose FH55-22S-0.5SH FPC connector
Connector to the camera	2 × FAKRA coaxial connector Code Z (water blue)
Connector to external power	3-pin Phoenix MC 1.5/3-G-3.5 terminal connector, matching cable connector Phoenix Contact MC 1,5/3-ST-3,5
Input voltage	4.5 VDC to 5.5 VDC or 10.8 VDC to 26.4 VDC
Power requirements	Max. 7 W (depending on the camera model)
GMSL2 deserializer chip	Analog Devices MAX96716AGTM/VY+T
Supported embedded boards	<ul style="list-style-type: none"> <li>NVIDIA Jetson AGX Orin DevKit, connected via 19616 Adapter Board for NVIDIA Jetson AGX Orin DevKit (under development)</li> <li>NVIDIA Jetson Xavier NX DevKit via 14948 Adapter Board for NVIDIA Jetson Nano and Jetson Xavier NX DevKit</li> </ul>
Supported cameras	Alvium FP3 Coax
Supported FAKRA coaxial cables for camera connections	Allied Vision 18424, 18425, 18426
Supported FPC cables	Allied Vision 12316, 12317, 12318, 18947
Dimensions (Length × width × height [mm])	77.4 × 50 × 14.7 (incl. connectors)
Mass (deserializer board only)	<30 g
Operating temperature <sup>1,2</sup>	-20 °C to +50 °C
Storage temperature	-20 °C to +70 °C
Relative humidity	0% to 80% (non-condensing)
<sup>1</sup> For personal protection against burns according to section 9.3 IEC 62368-1 <sup>2</sup> If enclosed in a housing, ensure that the component temperature of U8 does not exceed 105 °C. See <a href="#">Figure 5</a> on page 25.	

Table 5: Deserializer Board GMSL2 Coax to CSI-2 specifications overview



### Specifications of the deserializer chip

This deserializer board incorporates the GMSL2 deserializer chip Analog Devices MAX96716AGTM/VY+T. For specifications, see [www.analog.com](http://www.analog.com).



# PCB and PCBA number

The PCB number is printed to the FPC connector side as shown in [Figure 4](#). The PCBA number is printed on the label of the shipping bag.

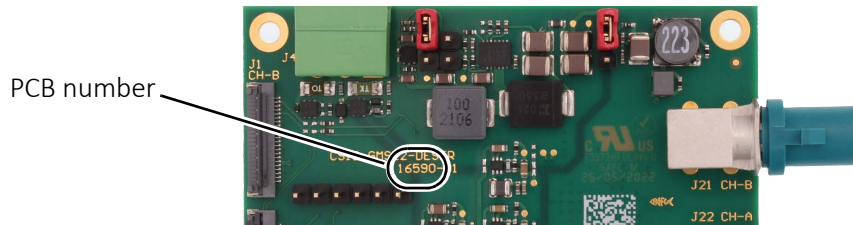

Figure 4: PCB number on deserializer boards

# Technical drawing

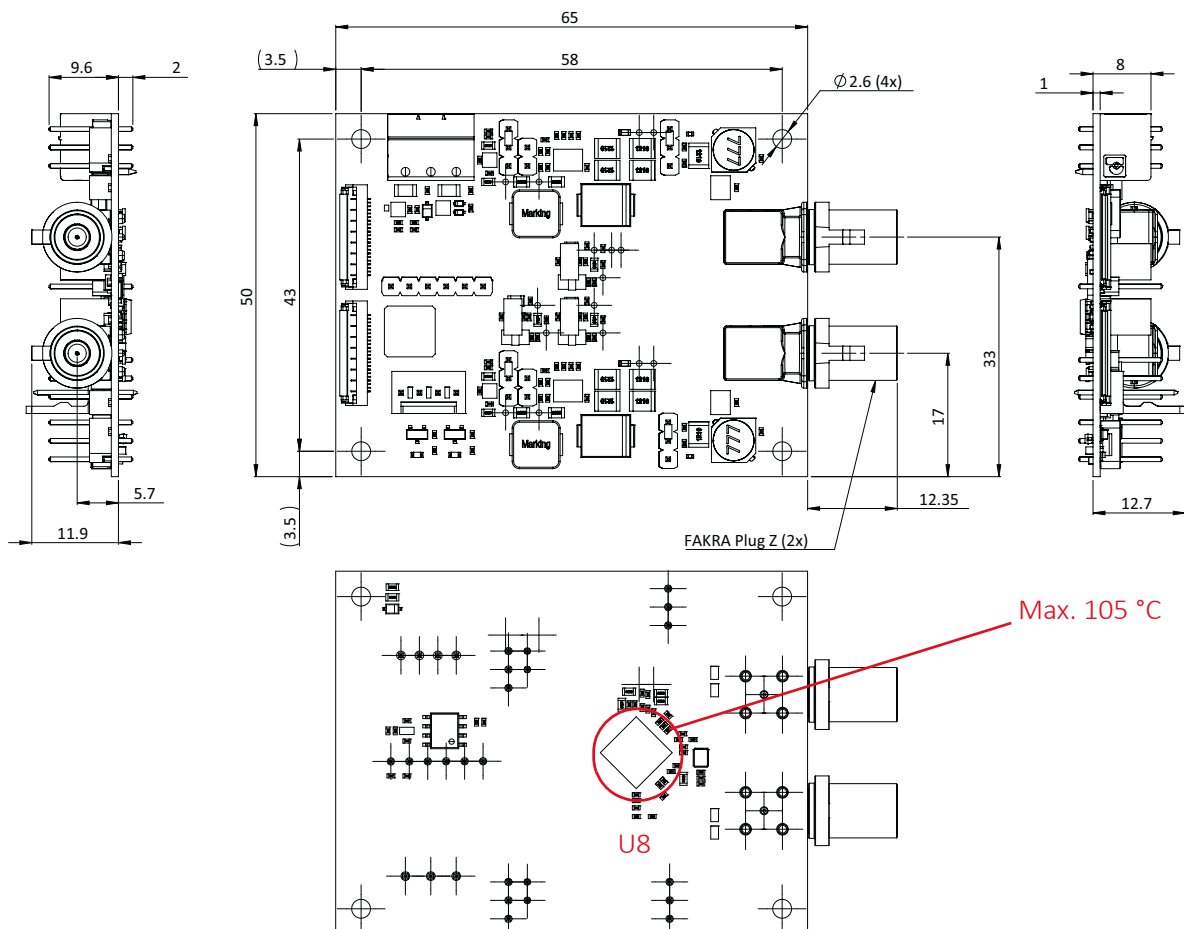

Figure 5: Deserializer Board GMSL2 Coax to CSI-2 dimensions and PCB layout

# Electronic schematics

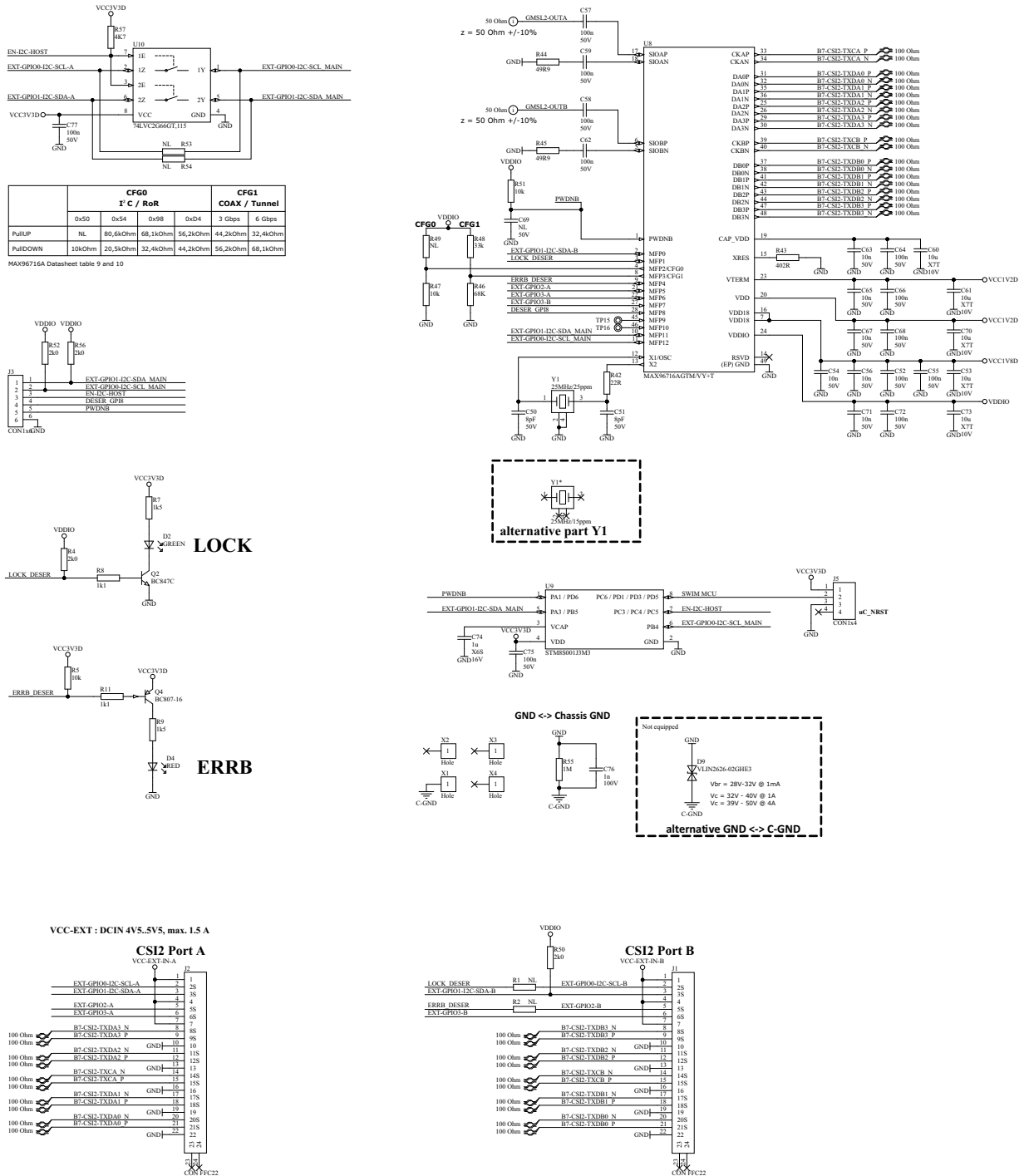

Figure 6: Deserializer Board GMSL2 Coax to CSI-2 electronic schematics, part 1

## Power circuits

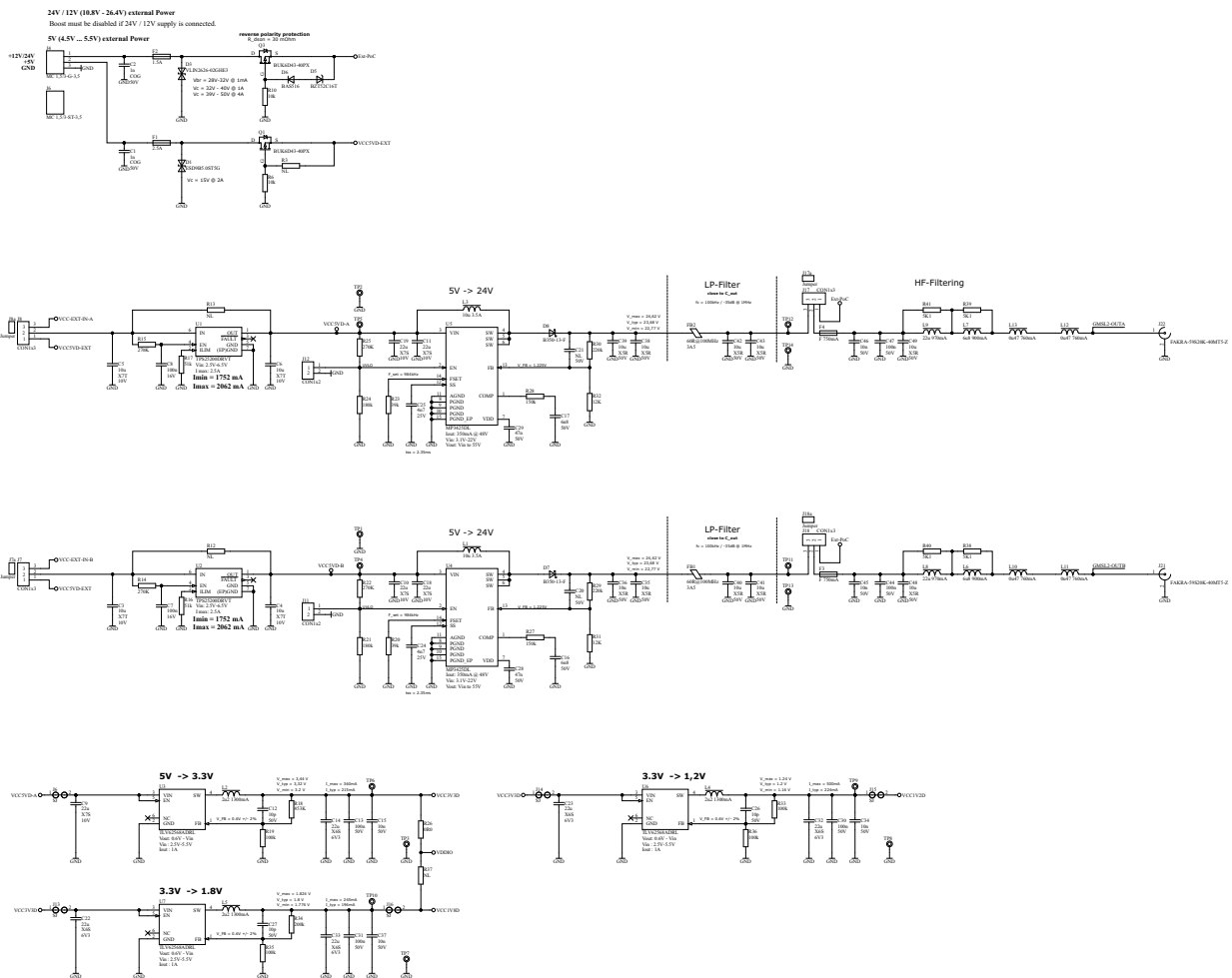

Figure 7: Deserializer Board GMSL2 Coax to CSI-2 electronic schematics, part 2

# Setting up deserializer boards



This chapter includes basic instructions on cable connectors:

Connecting FAKRA coaxial cables.....	29
Connecting FPC cables.....	31

Followed by instructions for:

Mounting deserializer boards.....	33
Connecting components to each other.....	33
Connecting power.....	34

# Connecting FAKRA coaxial cables

The robust FAKRA coaxial connectors are optimized for one-time plugging in the automotive industry. Unplugging cable connectors is uncomfortable, which may lead to camera damage. Please follow the instructions in this section.



## NOTICE

### Damage to cameras and connected peripherals

If FAKRA coaxial connectors are exposed to excessive stress, they can break off from the corresponding device.

- Secure coaxial cables at maximum 200 mm off the connected device.
- Follow the instructions below for FAKRA coaxial cables.

## FAKRA coaxial cable-side connectors

Figure 8 shows the latch of the locking mechanism of the FAKRA coaxial cable-side connectors in unlocked position (schematics):

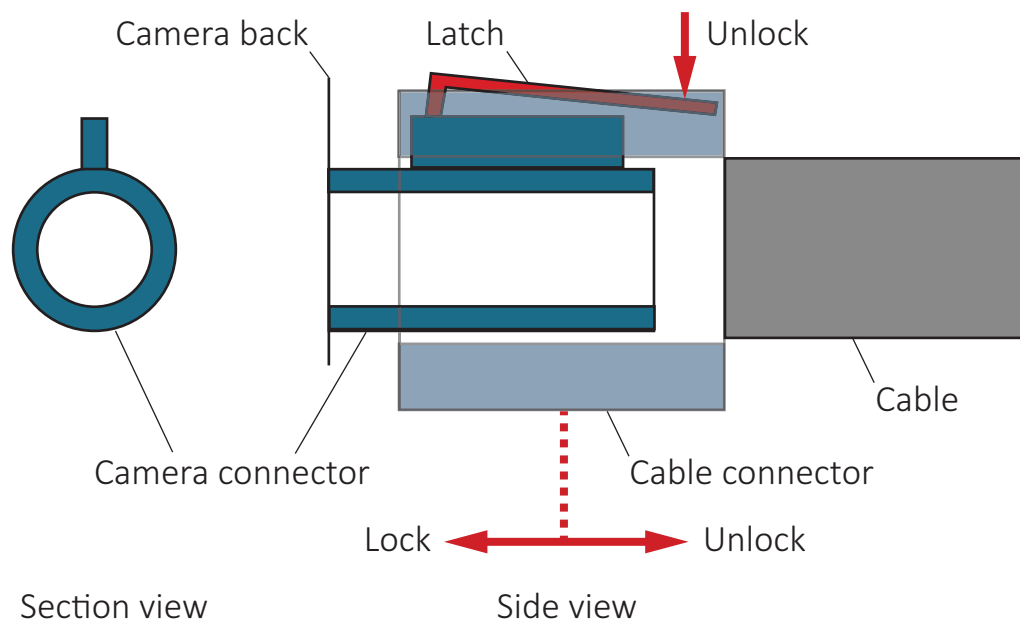

Figure 8: FAKRA coaxial cable-side connector: Locking mechanism

The cable-side connector has a locking mechanism that must be engaged for safe connection. To unplug the cable-side connector, the lever must be **pressed all the time while** the cable is pulled off the camera connector. Otherwise, the camera-side connector can be torn off the camera.

## Instructions for connecting

1. Grab the device (the camera in this example) with one hand and the cable-side connector with the other hand.
2. Align the groove (b) of the cable-side connector with the notch (a) of the device's connector.

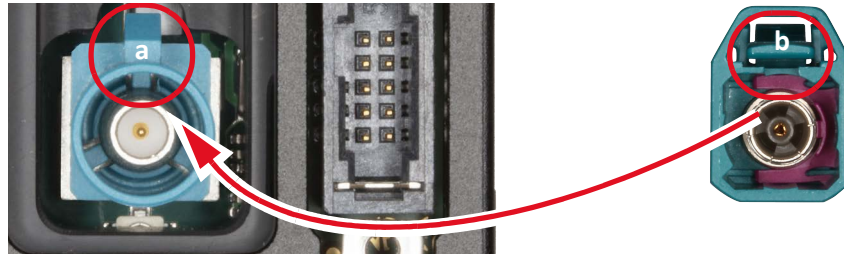

Figure 9: FAKRA coaxial connectors on cameras (left) and on cables (right)

3. Push the cable-side connector over the device's connector until it clicks.  
The device is connected properly.

## Instructions for disconnecting

1. Grab the device with one hand and the cable-side connector with the other hand.
2. With your fingernail, press down the latch (c) of the cable-side connector.



### NOTICE

#### Damage to cameras and connected peripherals

If the FAKRA coaxial connectors are exposed to excessive stress, they can break off from devices.

Keep the latch (c) pressed down until the cable has been completely disconnected from the device.

3. **Keeping the latch (c) pressed down**, pull the cable-side connector off the device. You may slightly rotate and tilt the cable-side connector against the device to reduce friction.

The camera is disconnected.



Figure 10: Pressing down the latch (c) of the FAKRA coaxial connector

# Connecting FPC cables

Figure 11 shows how the FPC cable connects to the FPC connector.

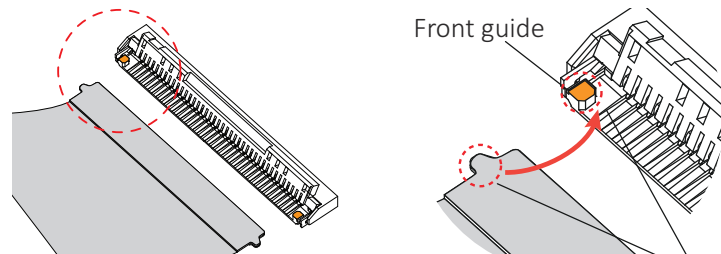

Figure 11: FPC cable and FPC connector (open position)

1. Opening the FPC connector: With your fingernail\*, flip the actuator to open position at 105° to the PCB surface, see Figure 12.

\*Or use a plastic tool, as metal tools can damage the actuator.

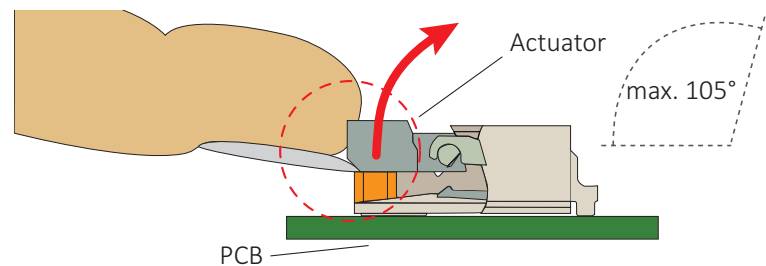

Figure 12: Opening the FPC connector



## NOTICE

### Damage to cameras or deserializer boards by reverse polarity

If deserializer boards or Alvium FP3/GM2 Coax cameras are powered with reverse polarity, electronics is damaged.

- Before connecting camera power, see [Electronic schematics](#) on page 26.
- Connect the cable as shown in this section.

Embedded board  
or adapter board



Deserializer board

Figure 13: FPC cable and data flow direction

2. **Ensuring proper cable orientation between devices to be connected**, take the FPC cable with conductors facing the FPC connector conductors (see [Figure 14](#) on page 32).

3. Inserting the FPC cable:  
At a horizontal angle of  $90^\circ$  to the connector's rear (see [Figure 14](#)) and at a vertical angle of  $12^\circ$  to the PCB (see [Figure 15](#)), slowly insert the FPC cable into the actuator...

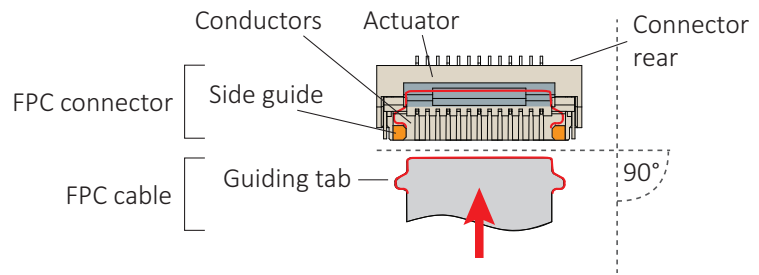

Figure 14: FPC cable and FPC connector

4. ...until cable guiding tabs are caught between connector rear and side guides (see [Figure 14](#)). Pull the cable slightly to ensure guiding tabs are properly engaged.
5. Holding the FPC cable in position, flap down the actuator to closed position (see [Figure 15](#)).

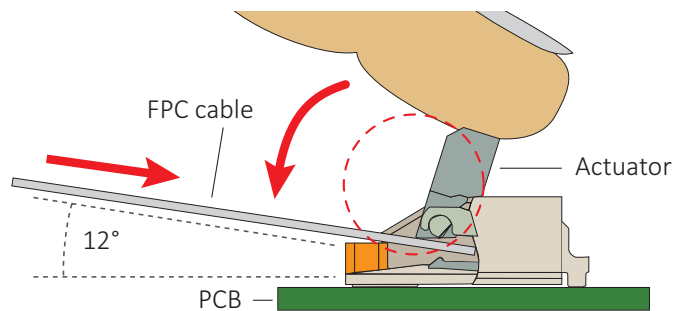

Figure 15: Engaging the FPC cable in the FPC connector



## Mounting deserializer boards



### CAUTION

#### Burns to the skin

Electrical components get hot during operation.

Before operation, include deserializer boards in housings that disable any contact to hot components.



### NOTICE

#### Damage to electronics

- Disconnect all power supplies before installing deserializer boards.
- Reconnect power only after installation is complete.
- Mount the embedded boards, deserializer boards, and cameras on common bases for strain relief.

1. Mount the deserializer board to a mounting base using 4 M2.5 screws with washers.
2. Prepare strain relief for all cable connections as described in [Strain relief for all cable connections](#) on page 20.



### NOTICE

#### Damage to cameras and connected peripherals

If FAKRA coaxial connectors are exposed to excessive stress, they can break off from devices. Hirose FH55 FPC connectors can be damaged easily.

- Secure cables at maximum 200 mm off the connected device, see [Strain relief for all cable connections](#) on page 20.
- See [Connecting FAKRA coaxial cables](#) on page 29.
- See [Connecting FPC cables](#) on page 31.

## Connecting components to each other

For connecting cameras to deserializer boards, follow the instructions in [Connecting FAKRA coaxial cables](#) on page 29. For connecting deserializer boards to the host, follow the instructions in [Connecting FPC cables](#) on page 31.

# Connecting power



## NOTICE

### Damage to power supplies

If power supplies do not provide sufficient current, they may be damaged.

Ensure external power supplies or embedded boards provide minimum 1500 mA for 5 VDC or minimum 600 mA for 12 VDC correspondingly.

1. Ensure all power supplies are disconnected from the mains power.
2. Set the jumpers as shown in [Figure 16](#):
  - a. For 5 VDC over FPC (default), set jumpers on **green** positions.
  - b. For 5 VDC over terminal connector, set jumpers on **blue** positions.
  - c. For 12 to 24 VDC over terminal connector, set jumpers on **blue** and on **red** positions.

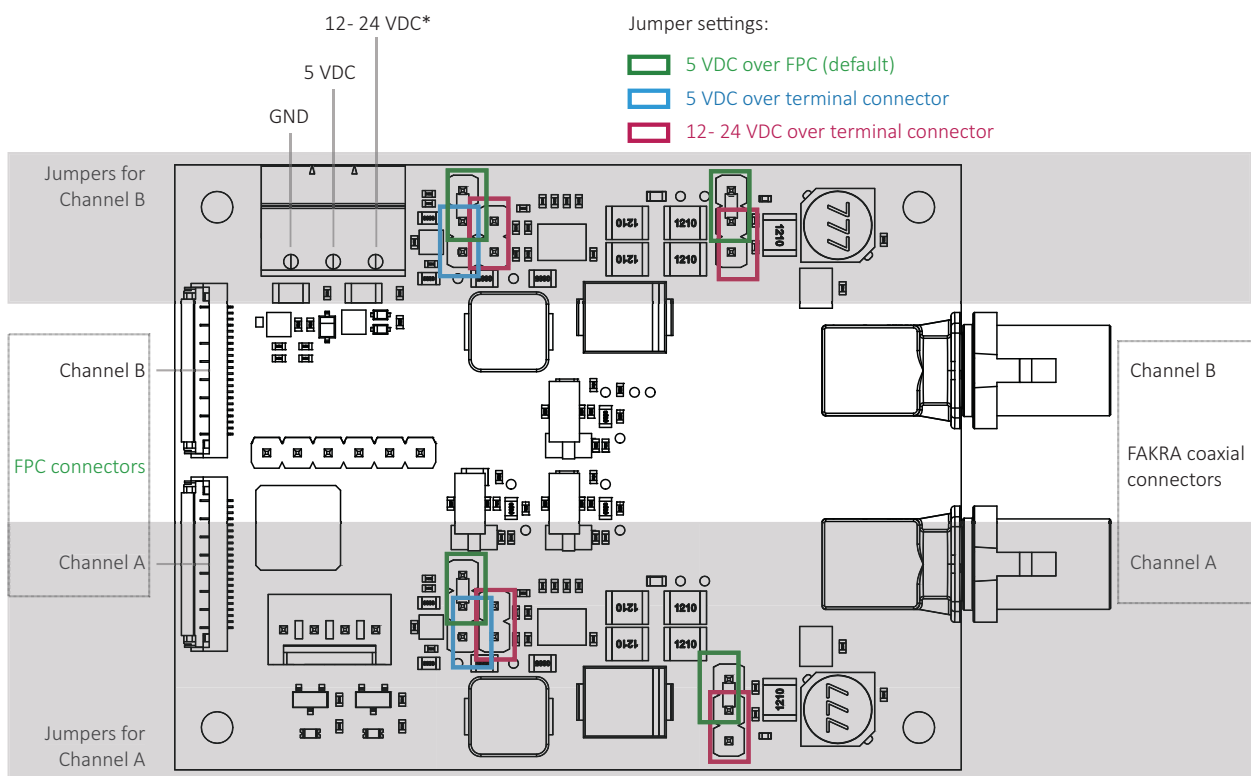

\* As a precondition, 5 VDC must be input in addition, using the terminal connector or the FPC connector.

*Figure 16: Connections and jumper settings for power supply*

3. Connect the power supplies to the mains power.
4. Power and boot the embedded system.

Your vision application is ready for first operation.